

# Xtreme Packages

311164J

EN

High performance, high pressure spray packages for protective coatings. For professional use only.



### Important Safety Instructions

Read all warnings and instructions in this manual.  
Save these instructions.

See page 4 for model information and maximum working pressures.

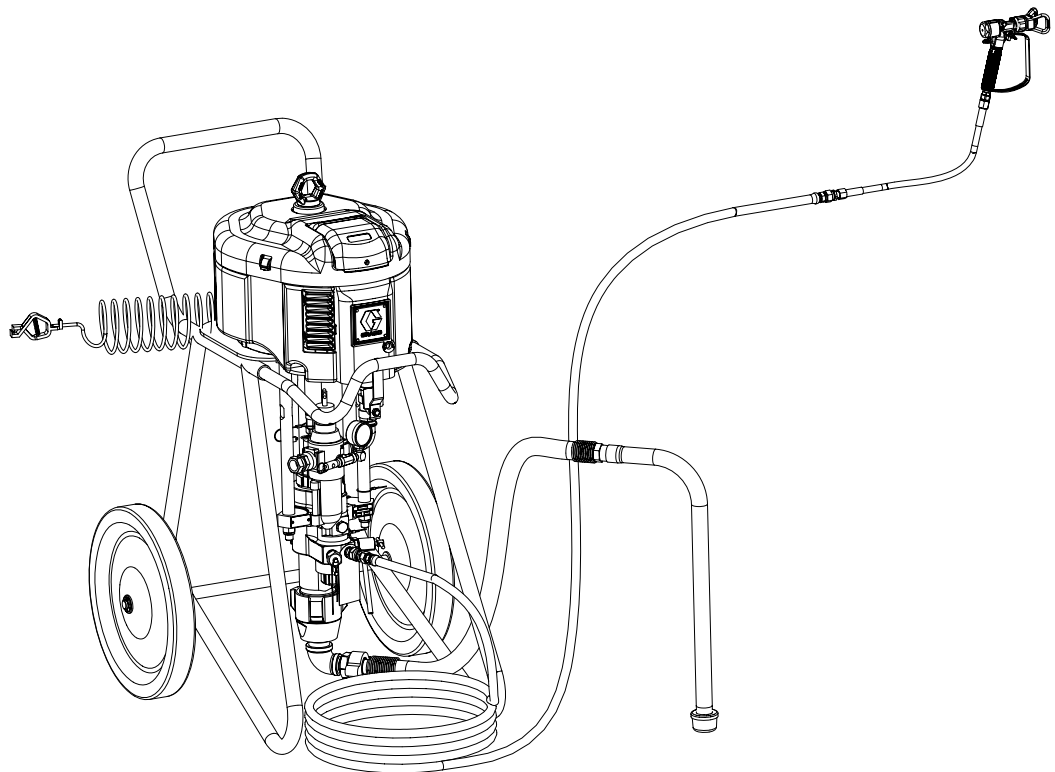

r\_x25dh1\_x45dl1\_311164\_1f



H003

# Contents

<b>Related Manuals</b> .....	3	<b>Pump Packages with L085C# Lowers (80:1 ratio)</b>	44
<b>Models</b> .....	4	<b>Pump Packages with L115C# Lowers (35:1, 55:1 ratio)</b> .....	45
Sprayer Packages .....	4	<b>Pump Packages with L145C# and L14AC1 Lowers (31:1, 46:1, 90:1 ratio)</b> .....	46
Specialty Sprayer Packages .....	5	<b>Pump Packages with L180C# and L18AC1 Lowers (24:1, 40:1, 70:1 ratio)</b> .....	47
Configurable Cart Packages .....	5	<b>Pump Packages with L220C# Lowers (21:1, 30:1, 60:1 ratio)</b> .....	48
Pump Packages .....	6	<b>Pump Packages with L250C# Lowers (50:1 ratio)</b>	49
<b>Warnings</b> .....	7	<b>Pump Packages with L290C# Lowers (16:1, 25:1, 45:1 ratio)</b> .....	50
<b>Component Identification - Cart Mount</b> .....	9	<b>Dimensions</b> .....	51
<b>Component Identification - Wall Mount</b> .....	10	Weights .....	53
System Components .....	11	<b>Mounting Hole Diagram</b> .....	54
<b>Grounding</b> .....	12	Wall Mount Bracket .....	54
<b>Setup</b> .....	12	<b>Accessories</b> .....	55
<b>Pressure Relief Procedure</b> .....	13	<b>Technical Data</b> .....	56
Trigger Lock .....	13	<b>Pump Package Performance Charts</b> .....	57
<b>Prime/Flush</b> .....	14	<b>Graco Standard Warranty</b> .....	60
<b>Spray</b> .....	16	<b>Graco Information</b> .....	60
Circulating Zinc Fluids .....	16		
<b>Shutdown</b> .....	17		
<b>Maintenance</b> .....	18		
Preventive Maintenance Schedule .....	18		
Daily Maintenance .....	18		
Corrosion Protection .....	18		
Cart Maintenance .....	18		
<b>DataTrak Controls and Indicators</b> .....	19		
<b>DataTrak Operation</b> .....	20		
Setup Mode .....	20		
Run Mode .....	20		
<b>Troubleshooting</b> .....	23		
<b>Xtreme Lower Removal</b> .....	24		
Disconnect and Reconnect Lower .....	24		
<b>Wall Mount Assembly</b> .....	26		
<b>Hopper Assembly</b> .....	26		
<b>Airless Xtreme Sprayer Parts</b> .....	28		
<b>Wall Mount Xtreme Package Parts</b> .....	29		
<b>Parts - Airless Xtreme Sprayer Packages</b> .....	30		
Component Parts - All Airless Sprayer Packages	30		
Common Parts .....	35		
<b>Air-Assisted Xtreme Sprayer Parts</b> .....	37		
<b>Zinc Xtreme Sprayer Parts</b> .....	38		
<b>Parts - Air-Assisted and Zinc Sprayer Packages</b>	39		
<b>Dura-Flo Sprayer Parts</b> .....	40		
<b>Parts - Dura-Flo Sprayer Packages</b> .....	41		
<b>Cart Parts</b> .....	42		
Heavy Duty Cart, Model 287884 .....	42		
Light Weight Cart, Model 287919 .....	42		
<b>Pump Package Parts</b> .....	43		

## Related Manuals

*Component Manuals in U.S. English:*

<b>Manual</b>	<b>Description</b>
311762	Xtreme Lower Instructions - Parts
311238	NXT Air Motor Instructions - Parts
311239	Integrated Air Control Modules for NXT Air Motors Instructions - Parts
311486	DataTrak™ Conversion Kit
3A0293	Air Controls for Heavy and Light Duty Carts Instructions-Parts

The Xtreme Packages manual is available in the following languages. See the following chart for specific languages and corresponding part numbers.

<b>Manual</b>	<b>Language</b>
311164	English
312437	Chinese
312438	Dutch
312439	Finnish
312440	French
312441	German
312442	Greek
312443	Italian
312444	Japanese
312445	Korean
312446	Portuguese
312447	Russian
312448	Spanish
312449	Swedish
312450	Turkish

# Models

## Sprayer Packages

### Airless Sprayers, Wall Mount Packages, and Hopper Packages

Check your sprayer, wall mount, or hopper package's identification plate (ID) for the 6-digit part number of your package. Use the following matrix to define the construction of your package, based on the six digits. For example, Sprayer Part Number **X 60 D H 1** represents the Xtreme brand (**X**), pressure ratio (**60 :1**), de-icing motor (**D**), heavy duty cart (**H**), and complete package (gun and hose included) with DataTrak™ (**1**). To order replacement parts, see **Airless Xtreme Sprayer Parts** section starting on page 28. The digits in the matrix do not correspond to the reference numbers in the Parts drawings and lists.

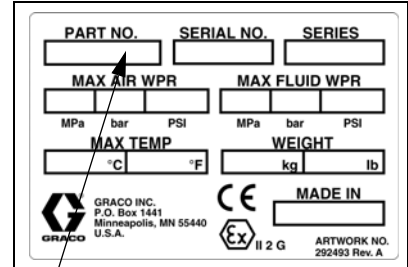

ID

 **NOTE: All models have a maximum air input pressure of 100 psi (.7 MPa, 7 bar). Models with a 90:1 pressure ratio have a maximum air input pressure of 80 psi (0.55 MPa, 5.5 bar).**

<b>X</b>	<b>60</b>	<b>D</b>		<b>H</b>		<b>1</b>		
<b>First Digit</b>	<b>Second and Third Digit</b>	<b>Fourth Digit</b>		<b>Fifth Digit</b>		<b>Sixth Digit</b>		
	<b>Pressure Ratio (xx:1)</b>	<b>Motor / Exhaust</b>		<b>Mount Option</b>		<b>Complete Package</b>	<b>DataTrak</b>	<b>Hopper</b>
<b>X</b> (Xtreme brand)	<b>25</b>	D	De-Icing	H	Heavy Duty	1	✓	✓
	<b>30</b>	L	Low Noise	L	Light Weight	2		✓
	<b>35</b>			W	Wall Mount	3	✓	
	<b>40</b>					4		
	<b>45</b>					5	✓	✓
	<b>46</b>					6	✓	
	<b>50</b>							✓
	<b>55</b>							
	<b>60</b>							
	<b>70</b>							
	<b>80</b>							
<b>90</b>								

## Specialty Sprayer Packages

### Wall Mount Package 287978

Model 287978 is a 40:1 ratio unit that includes a low noise motor, DataTrak, external filter, and no gun or hose.

### Air-Assisted Sprayers

All air-assisted sprayers include a de-icing motor, a heavy duty cart, DataTrak, G40 spray gun, and hose.

30:1 Pressure Ratio - 287975

40:1 Pressure Ratio - 287976

### Zinc Sprayers

All zinc sprayers include a de-icing motor and a heavy duty cart. Models 287973 and 287974 also include Silver spray gun and hose.

25:1 Pressure Ratio - 287971

40:1 Pressure Ratio - 287972

25:1 Pressure Ratio - 287973

40:1 Pressure Ratio - 287974

### Dura-Flo™ Sprayers

All Dura-Flo sprayers include a de-icing motor, a heavy duty cart, and Dura-Flo pump package. Only model 287980 includes a gun and hose.

23:1 Pressure Ratio - 287979

23:1 Pressure Ratio - 287980

32:1 Pressure Ratio - 287981

## Configurable Cart Packages

 **NOTE: Configurable cart packages do not include lowers. Pair these packages with any Xtreme lower (145cc - 290cc) for a sprayer package.**

All models include air controls, tie rods, coupling kit, and suction hose. Use the following matrix to define the construction of your cart package, based on the six digits. For example, cart package number **X N3 D H 2** represents the Xtreme brand (**X**), motor (**NXT3400**), de-icing motor (**D**), heavy duty cart (**H**), and bare package with DataTrak™ (**2**).

<b>X</b>	<b>N3</b>		<b>D</b>		<b>H</b>		<b>2</b>	
First Digit	Second and Third Digit		Fourth Digit		Fifth Digit		Sixth Digit	
		Motor		Exhaust		Mount Option		DataTrak
X (Xtreme brand)	N3	<b>NXT3400</b>	D	De-Icing	H	Heavy Duty	2	✓
	N6	<b>NXT6500</b>			L	Light Weight	4	

# Pump Packages

Check your pump package's identification plate (ID) for the 6-digit part number of your pump package. For example, Pump Part Number **P 30 M C 1** represents the pump (**P**), pressure ratio (**30 :1**), low noise exhaust motor with DataTrak™ (**M**), carbon steel construction (**C**), and no built-in filter or air controls (**1**). For

To order replacement parts, see **Pump Package Parts** section starting on page 43. The digits in the matrix do not correspond to the reference numbers in the Parts drawings and lists.

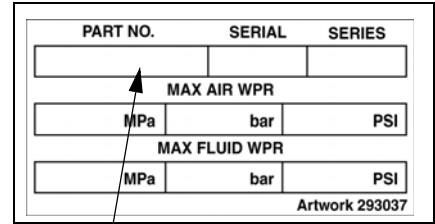











 **NOTE: Models with 16:1 - 70:1 pressure ratios have a maximum air input pressure of 100 psi (.7 MPa, 7 bar). Models with a 90:1 pressure ratio have a maximum air input pressure of 80 psi (0.55 MPa, 5.5 bar).**

<b>P</b>	<b>30</b>	<b>M</b>			<b>C</b>	<b>1</b>		
<b>First Digit</b>	<b>Second and Third Digit</b>	<b>Fourth Digit</b>			<b>Fifth Digit</b>		<b>Sixth Digit</b>	
	<b>Pressure Ratio (xx:1)</b>	<b>Exhaust</b>	<b>Communication</b>		<b>Lower Construction</b>	<b>Built-in Filter</b>	<b>Air Controls</b>	
<b>P</b> (pumps)	16	D	De-Icing	none	C	Carbon Steel	1	
	21	E	De-Icing	DataTrak			2	✓
	24	L	Low Noise	none			3	✓
	25	M	Low Noise	DataTrak			4	✓
	30							
	31							
	35							
	40							
	45							
	46							
	50							
	55							
	60							
	70							
	80							
90								

# Warnings

The following warnings are for the setup, use, grounding, maintenance, and repair of this equipment. The exclamation point symbol alerts you to a general warning and the hazard symbols refer to procedure-specific risks. Refer back to these Warnings. Additional, product-specific warnings may be found throughout the body of this manual where applicable.

 <b>WARNING</b>	
	<p><b>FIRE AND EXPLOSION HAZARD</b></p> <p>Flammable fumes, such as solvent and paint fumes, in <b>work area</b> can ignite or explode. To help prevent fire and explosion:</p> <ul style="list-style-type: none"> <li>• Use equipment only in well ventilated area.</li> <li>• Eliminate all ignition sources; such as pilot lights, cigarettes, portable electric lamps, and plastic drop cloths (potential static arc).</li> <li>• Keep work area free of debris, including solvent, rags and gasoline.</li> <li>• Do not plug or unplug power cords, or turn power or light switches on or off when flammable fumes are present.</li> <li>• Ground all equipment in the work area. See <b>Grounding</b> instructions.</li> <li>• Use only grounded hoses.</li> <li>• Hold gun firmly to side of grounded pail when triggering into pail.</li> <li>• If there is static sparking or you feel a shock, <b>stop operation immediately</b>. Do not use equipment until you identify and correct the problem.</li> <li>• Keep a working fire extinguisher in the work area.</li> </ul>
	<p><b>BATTERY HAZARD</b></p> <p>Sparking can occur when changing batteries. The battery may cause an explosion if mishandled:</p> <ul style="list-style-type: none"> <li>• You must use the battery type specified for use with the equipment.</li> <li>• Only replace the battery in a non-hazardous location, away from flammable fluids or fumes.</li> </ul>
	<p><b>SKIN INJECTION HAZARD</b></p> <p>High-pressure fluid from gun, hose leaks, or ruptured components will pierce skin. This may look like just a cut, but it is a serious injury that can result in amputation. <b>Get immediate surgical treatment.</b></p> <ul style="list-style-type: none"> <li>• Do not point gun at anyone or at any part of the body.</li> <li>• Do not put your hand over the spray tip.</li> <li>• Do not stop or deflect leaks with your hand, body, glove, or rag.</li> <li>• Do not spray without tip guard and trigger guard installed.</li> <li>• Engage trigger lock when not spraying.</li> <li>• Follow <b>Pressure Relief Procedure</b> in this manual, when you stop spraying and before cleaning, checking, or servicing equipment.</li> </ul>

 <b>WARNING</b>	
	<p><b>EQUIPMENT MISUSE HAZARD</b></p> <p>Misuse can cause death or serious injury.</p> <ul style="list-style-type: none"> <li>• Do not operate the unit when fatigued or under the influence of drugs or alcohol.</li> <li>• Do not exceed the maximum working pressure or temperature rating of the lowest rated system component. See <b>Technical Data</b> in all equipment manuals.</li> <li>• Use fluids and solvents that are compatible with equipment wetted parts. See <b>Technical Data</b> in all equipment manuals. Read fluid and solvent manufacturer's warnings. For complete information about your material, request MSDS forms from distributor or retailer.</li> <li>• Check equipment daily. Repair or replace worn or damaged parts immediately with genuine Graco replacement parts only.</li> <li>• Do not alter or modify equipment.</li> <li>• Use equipment only for its intended purpose. Call your Graco distributor for information.</li> <li>• Route hoses and cables away from traffic areas, sharp edges, moving parts, and hot surfaces.</li> <li>• Do not kink or over bend hoses or use hoses to pull equipment.</li> <li>• Keep children and animals away from work area.</li> <li>• Comply with all applicable safety regulations.</li> </ul>
 	<p><b>MOVING PARTS HAZARD</b></p> <p>Moving parts can pinch or amputate fingers and other body parts.</p> <ul style="list-style-type: none"> <li>• Keep clear of moving parts.</li> <li>• Do not operate equipment with protective guards or covers removed.</li> <li>• Pressurized equipment can start without warning. Before checking, moving, or servicing equipment, follow the <b>Pressure Relief Procedure</b> in this manual. Disconnect power or air supply.</li> </ul>
	<p><b>TOXIC FLUID OR FUMES HAZARD</b></p> <p>Toxic fluids or fumes can cause serious injury or death if splashed in the eyes or on skin, inhaled, or swallowed.</p> <ul style="list-style-type: none"> <li>• Read MSDS's to know the specific hazards of the fluids you are using.</li> <li>• Store hazardous fluid in approved containers, and dispose of it according to applicable guidelines.</li> </ul>
	<p><b>PERSONAL PROTECTIVE EQUIPMENT</b></p> <p>You must wear appropriate protective equipment when operating, servicing, or when in the operating area of the equipment to help protect you from serious injury, including eye injury, inhalation of toxic fumes, burns, and hearing loss. This equipment includes but is not limited to:</p> <ul style="list-style-type: none"> <li>• Protective eyewear</li> <li>• Clothing and respirator as recommended by the fluid and solvent manufacturer</li> <li>• Gloves</li> <li>• Hearing protection</li> </ul>



# Component Identification - Cart Mount

- |   |   |   |                                       |
|---|---|---|---------------------------------------|
| A | Air Inlet, 3/4 npt(f)                                       | K | Fluid Filter                          |
| B | Bleed Type Master Air Valve (required)                      | L | Grounding Wire (required)             |
| C | Air Pressure Relief Valve                                   | M | Lower                                 |
| D | Air Filter (hidden)   | N | Suction Hose and Tube                 |
| E | Air Pressure Gauge  | P | Fluid Outlet                          |
| F | Air Regulator Adjustment Knob                               | R | Optional Fluid Outlet, for second gun |
| G | DataTrak™ location (see page 19; not present on all models) | S | Packing Nut                           |
| J | Fluid Drain/Purge Valve (required)                          | T | De-Ice Control                        |

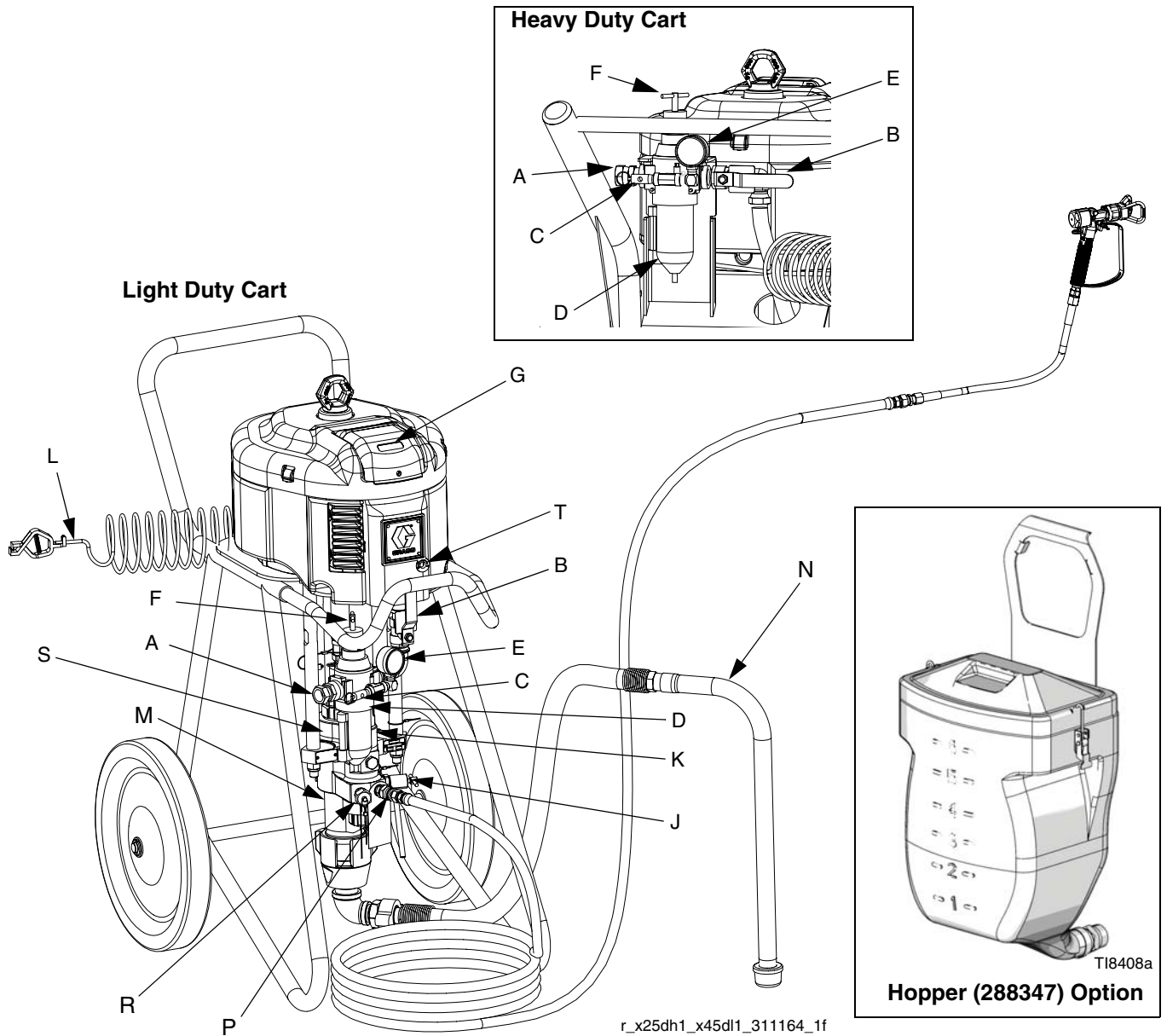
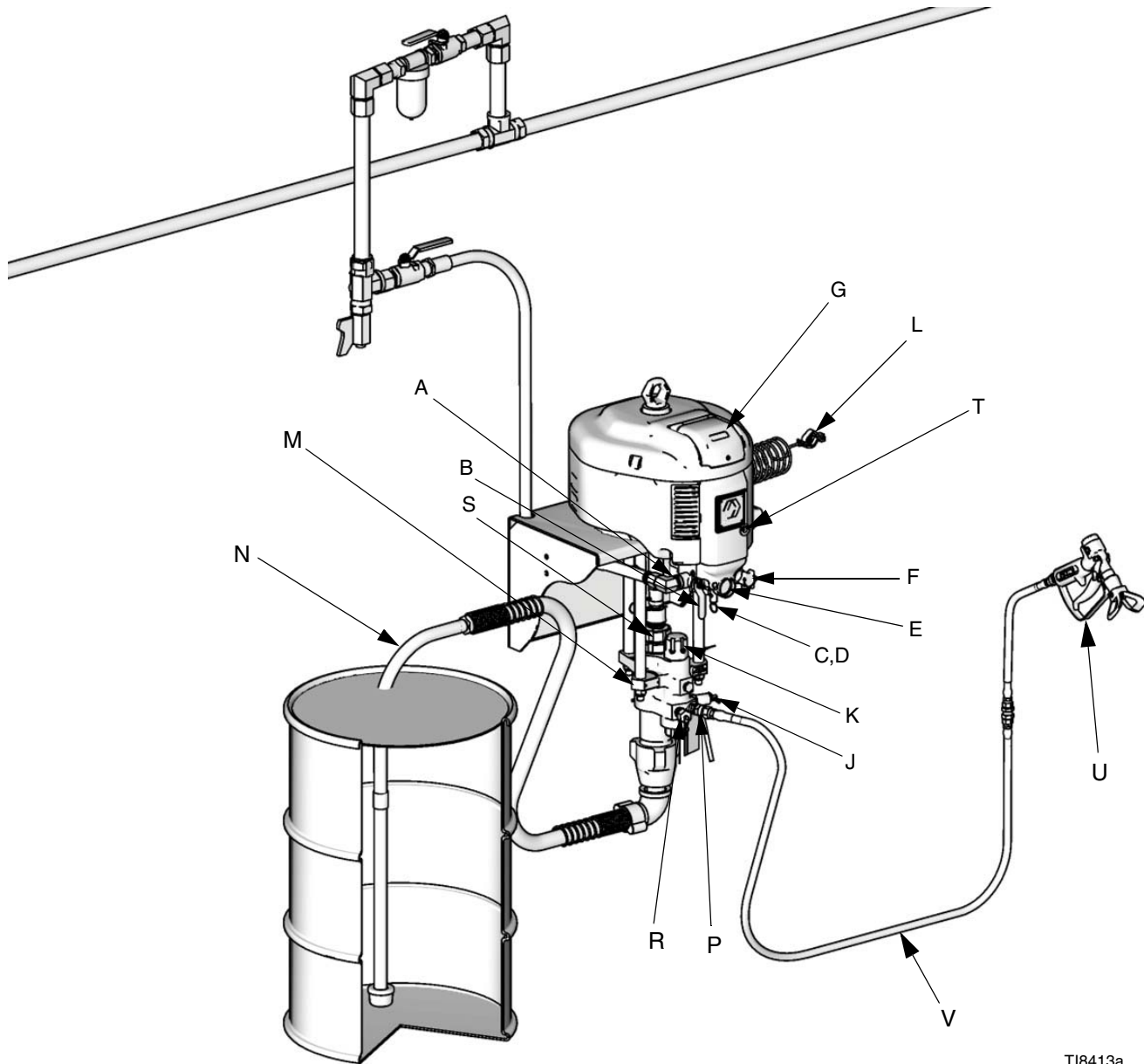

FIG. 1: Airless Sprayer

# Component Identification - Wall Mount

- |   |   |   |                                       |
|---|---|---|---------------------------------------|
| A | Air Inlet, 3/4 npt(f)                                       | L | Grounding Wire (required)             |
| B | Bleed Type Master Air Valve (required)                      | M | Lower                                 |
| C | Air Pressure Relief Valve                                   | N | Suction Hose and Tube                 |
| D | Air Filter (hidden)   | P | Fluid Outlet                          |
| E | Air Pressure Gauge  | R | Optional Fluid Outlet, for second gun |
| F | Air Regulator Adjustment Knob                               | S | Packing Nut                           |
| G | DataTrak™ location (see page 19; not present on all models) | T | De-Ice Control                        |
| J | Fluid Drain/Purge Valve (required)                          | U | Spray Gun                             |
| K | Fluid Filter  | V | Hose                                  |





TI8413a

FIG. 2: Wall Mount System

## System Components

### \* Bleed Type Master Air Valve (B)

						
Trapped air can cause the pump to cycle unexpectedly, which could result in serious injury from splashing or moving parts.						

- Be sure the valve is easily accessible from the pump and located downstream from the air regulator.
- Required in your system to relieve air trapped between it and the air motor when the valve is closed.
  - Open to supply air to the motor.
  - Close to shut off air to the motor, and bleed any trapped air from the motor.

### \* Air Pressure Relief Valve (C)

Automatically opens to relieve air pressure if supplied pressure exceeds preset limit.

### Air Filter (D)

Removes harmful dirt from compressed air supply.

### Air Regulator Adjustment (F)

Adjusts air pressure to the motor and fluid outlet pressure of pump. Locate it close to the pump. Read air pressure on gauge (E).

### \* Fluid Drain/Purge Valve (J)

Open valve to relieve pressure and when flushing or priming pump. Close valve when spraying.

### De-Ice Control (T)

Turn knob (open) to reduce icing.



T18160b

\* Required system components.

# Grounding

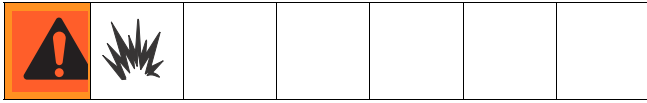

The equipment must be grounded. Grounding reduces the risk of static and electric shock by providing an escape wire for the electrical current due to static build up or in the event of a short circuit.

**Table 1: Tools Required**

- Grounding wires and clamps for pails
- Two 5 gal. (19 liter) metal pails

1. Connect the ground wire (244524) (L) to the ground stud on the air motor.

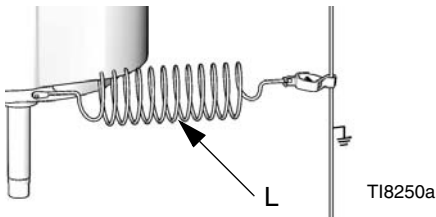

**FIG. 3**

2. Connect the other end of the ground wire to a true earth ground.
3. Ground the object being sprayed, fluid supply container, and all other equipment in the work area. Follow your local code. Use only electrically conductive air and fluid hoses.
4. Ground all solvent pails. Use only metal pails, which are conductive, placed on a grounded surface. Do not place pail on a nonconductive surface, such as paper or cardboard, which interrupts grounding continuity.

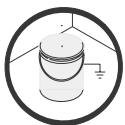

TI1102-1



TI1102-2

# Setup

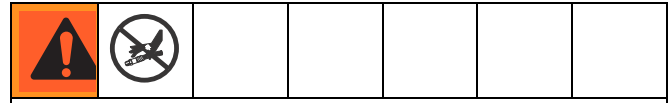

To avoid tip over, ensure cart is on a flat and level surface. Failure to do so could result in injury or equipment damage.

**Table 2: Tools Required**

- Two adjustable wrenches
- Non-sparking hammer or plastic mallet
- Torque wrench

1. Ground sprayer.
2. Check packing nut (S). Fill with Throat Seal Liquid (TSL). Torque to 25-30 ft-lb (34-41 N•m).

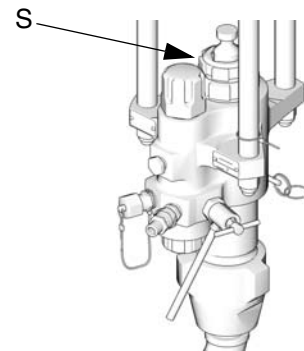

TI8316a

3. Attach electrically conductive fluid hose to pump outlet and tighten.
4. Attach electrically conductive fluid hose (and air hose if using an AA gun) to gun and tighten.
5. Close bleed type master air valve (B). Connect air supply hose to 3/4 npt(f) air inlet (A).

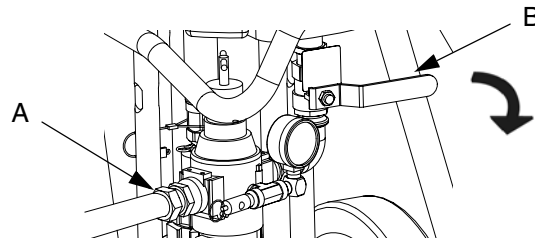

6. Flush before using. See page 14.
7. Prime before using. See page 14.

# Pressure Relief Procedure



1. Engage gun trigger lock.



T15049a

2. Close bleed type master air valve (B).

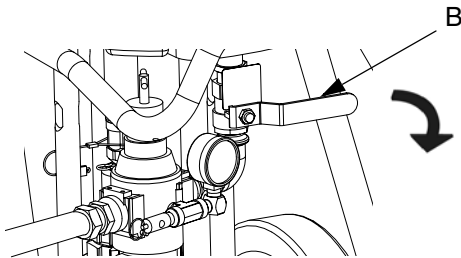

3. Disengage gun trigger lock.

 **NOTE: If using an AA gun, turn gun air regulator counter-clockwise to relieve pressure.**



T15048a

4. Hold gun firmly against a grounded metal pail. Trigger the gun.



T18252a

5. Engage gun trigger lock.

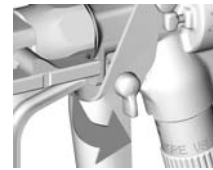

T15049a

6. Drain fluid. To drain fluid, slowly open all fluid drain valves, including drain/purge valve (J), in system into a waste pail. If there is a return tube, open return line ball valve.

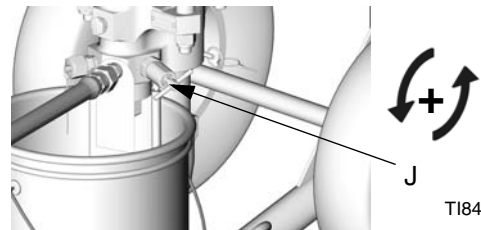

T18417a

7. If you suspect the spray tip or hose is completely clogged, or that pressure has not been fully relieved after following the previous steps, very slowly loosen the tip guard retaining nut or hose end coupling and relieve pressure gradually; then loosen completely. With tip removed, trigger gun into bucket.

## Trigger Lock

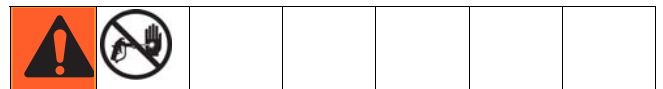

Always engage gun trigger lock when you stop spraying to prevent gun from being triggered accidentally by hand or if dropped or bumped.

# Prime/Flush



1. Follow **Pressure Relief Procedure**, page 13.
2. Remove tip and tip guard from gun.
3. *Flushing only:* If desired, remove built-in fluid filter (present on some models). Reinstall filter cap after removing fluid filter.
4. Place suction tube in a compatible fluid (if priming) or solvent (if flushing).

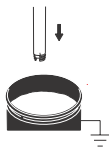

*Zinc sprayers only:* Place return tube in a compatible fluid (if priming) or solvent (if flushing). Open return line valve.

5. Turn regulator adjustment knob (G) counterclockwise until it stops, and gauge (E) reads zero.

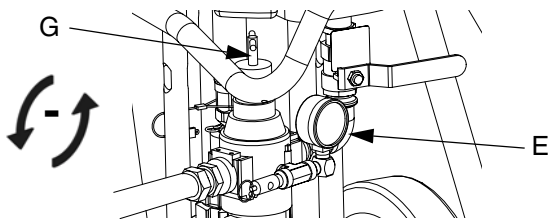

6. Open bleed type master air valve (B).

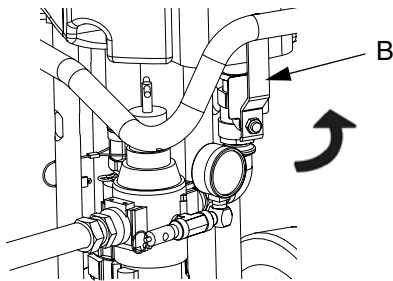

*Zinc sprayers only:* When clean solvent or fluid flows from return tube, close return line valve. Pump will stall.

7. Prime or flush hose and gun:
  - a. Disengage gun trigger lock.



- b. Trigger gun into grounded pail until a steady stream comes from gun. **If flushing**, trigger gun for 10-15 seconds.



**NOTE:** If using an AA gun, increase air pressure by turning gun regulator clockwise.

- c. Engage trigger lock.
8. If priming, equipment is now ready to spray; go to **Spray**, page 16.

If flushing, proceed with step 9.

 **NOTE: The remaining steps are for flushing only.**

<b>CAUTION</b>
Do not prime pump through drain/purge valve using two component materials. Mixed two-component materials will harden in valve and result in clogging.

- Place drain tube in a grounded waste pail.

Open drain/purge valve (J) slightly by rotating counterclockwise.

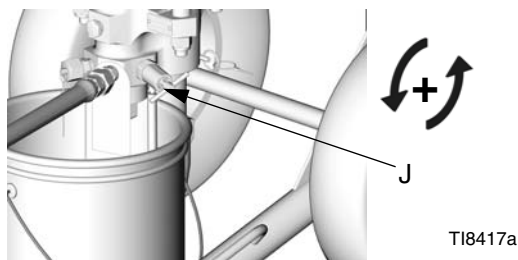

- Start the pump by rotating the air regulator adjustment knob (G) clockwise until pump begins to move.

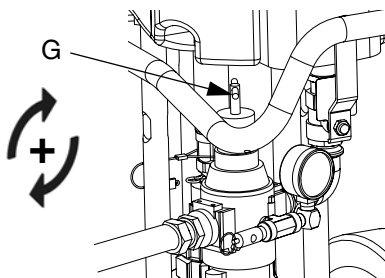

- When clean solvent flows from drain tube close drain/purge valve (J) by rotating clockwise. Pump will stall.

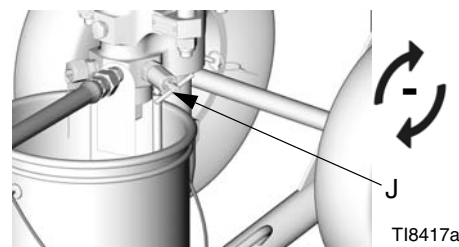

- Follow **Pressure Relief Procedure**, page 13. Leave solvent in and store sprayer.

# Spray

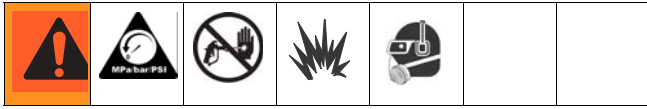

## CAUTION

Do not allow pump to run dry. It will quickly accelerate to a high speed causing damage.

1. Prime. See **Prime/Flush**, page 14.
2. Follow **Pressure Relief Procedure**, page 13.
3. Install tip and tip guard on gun.
4. Open bleed type master air valve (B).

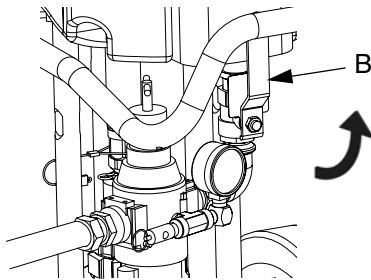

5. Turn regulator adjustment knob (G) until gauge (E) reads desired pressure. Turn clockwise to increase pressure, counterclockwise to decrease pressure.

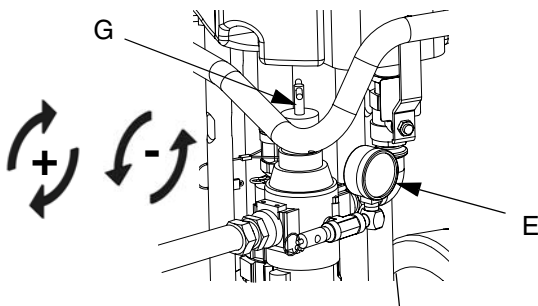

6. Disengage gun trigger lock.



7. Spray a test pattern. Read fluid manufacturer's recommendations. Adjust as necessary. If using an AA gun, increase gun air pressure while testing spray pattern.



8. *Zinc sprayers only:* When not spraying, reduce air pressure to 30 psi (2.1 MPa, 21 bar). Open return line and close gun valve.
9. Flush when done spraying. See **Prime/Flush**, page 14.
10. Follow **Pressure Relief Procedure**, page 13.

## Circulating Zinc Fluids

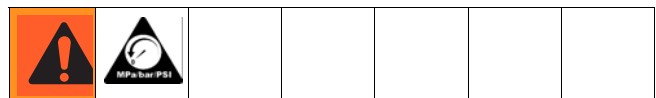

1. When spraying zinc fluids, close return line valve. Circulation is not required when spraying.
2. To circulate fluid back to supply container while you are not spraying, open return line valve and lock gun trigger safety. Pump will continue to run.
3. **Always relieve pressure** before overnight shut-down, when changing spray tips, or when checking or servicing any part of system. During circulation, some fluid will be present in gun line and must be relieved.



# Shutdown



**CAUTION**

Never leave water or water-base fluid in pump overnight. If you are pumping water-base fluid, flush with water first, then with a rust inhibitor, such as mineral spirits. Relieve pressure, but leave rust inhibitor in pump to protect parts from corrosion.

1. Follow **Pressure Relief Procedure**, page 13.
2. Remove tip and tip guard from gun.
3. Engage gun trigger lock.



TI5049a

4. Place siphon tube in grounded metal pail containing cleaning fluid.

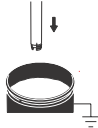

5. Open bleed type master air valve (B). Turn regulator adjustment knob (G) counterclockwise to lowest possible fluid pressure.

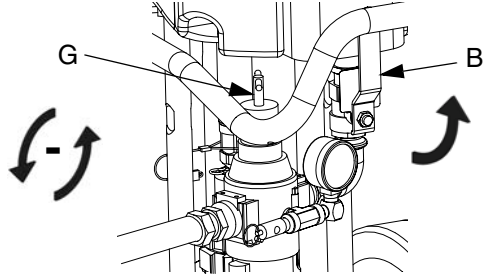

6. Hold a metal part of the gun firmly to a grounded metal pail. Trigger the gun until clean solvent dispenses.

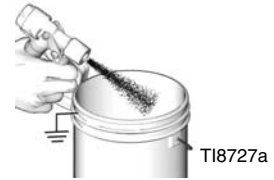

TI8727a

7. Follow **Pressure Relief Procedure**, page 13.

# Maintenance

## Preventive Maintenance Schedule

The operating conditions of your particular system determine how often maintenance is required. Establish a preventive maintenance schedule by recording when and what kind of maintenance is needed, and then determine a regular schedule for checking your system.

## Daily Maintenance

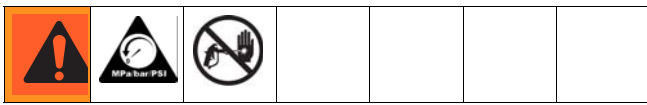

**NOTE:** For overnight shutdown, stop pump at bottom of its stroke to prevent fluid from drying on exposed displacement rod and damaging throat packings. Follow Pressure Relief Procedure, page 13.

1. Flush. See **Prime/Flush**, page 14.
2. Relieve pressure. See **Pressure Relief Procedure**, page 13.
3. Check packing nut (S, FIG. 1). Adjust packings and replace TSL as necessary. Torque to 25-30 ft-lb (34-41 N•m).
4. Drain water from air filter.
5. Clean suction tube using a compatible solvent. It is recommended that you clean the outside of the sprayer using a cloth and compatible solvent.
6. Check hoses, tubes, and couplings. Tighten all fluid connections before each use.
7. Clean fluid line filter.

## Corrosion Protection

Always flush the pump before the fluid dries on the displacement rod. Never leave water or water-based fluid in the pump overnight. First, flush with water or a compatible solvent, then with mineral spirits. Relieve the pressure, but leave the mineral spirits in the pump to protect the parts from corrosion.

## Cart Maintenance

Periodically lubricate the axle between points A and B with lightweight oil. See FIG. 4.

Keep the cart clean by wiping up spills daily, using a compatible solvent.

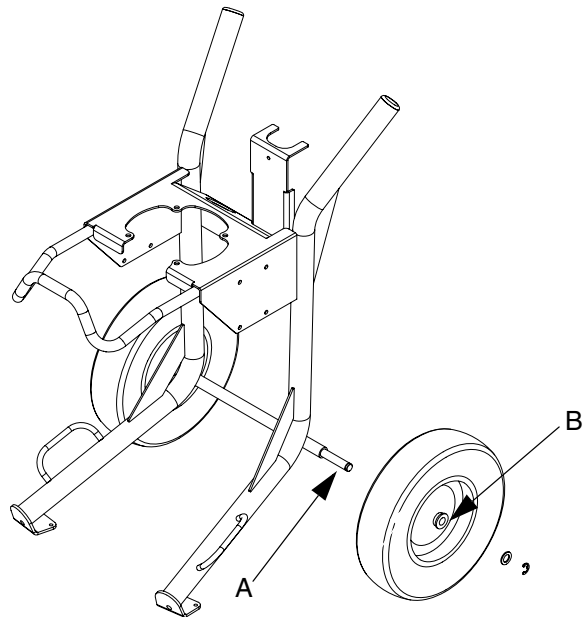

r\_x25dh1\_x45dh1\_311164\_38f

**FIG. 4: Cart Assembly - Heavy Duty Model Shown**

# DataTrak Controls and Indicators

 **NOTE: DataTrak is included with certain models. See Models, page 4, for a list of models featuring DataTrak.**

## Key for FIG. 5

- |    |  |    |   |
|----|--|----|---|
| T  | Runaway Limit, in cycles per minute (user settable; 00=OFF)  | RK | Reset Key (Resets faults. Press and hold for 3 seconds to clear the batch totalizer.) |
| U  | Lower Displacement (user settable)   | CF | Cycle/Flow Rate   |
| V  | Flow Rate Units (user settable to $\updownarrow$ /min, gpm [US], gpm [Imperial], oz/min [US], oz/min [Imperial], l/min, or cc/min)                 | BT | Batch Totalizer   |
| W  | LED (fault indicator when lit)   | GT | Grand Totalizer   |
| X  | Diagnostic Reference Card (see TABLE 3, page 22)   | RT | Runaway Toggle (enable/disable)   |
| Y  | Display  | UT | E1 Error Option (enable/disable)  |
| PF | Prime/Flush Key (Enables Prime/Flush mode. While in Prime/Flush mode, runaway protection is disabled and the batch totalizer (BT) will not count.) | DT | E2 Error Option (enable/disable)  |
|    |  | ST | E5 Error Option (enable/disable)  |

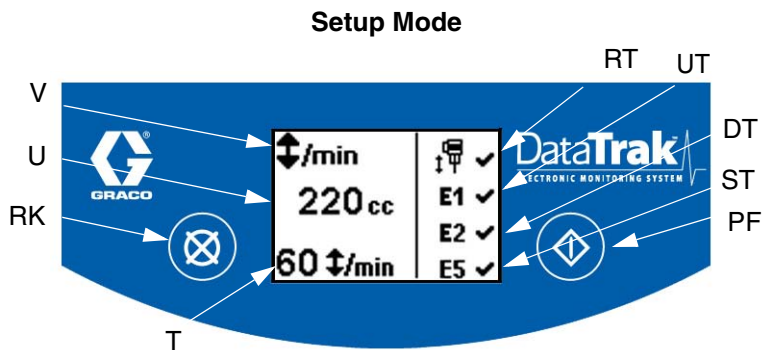
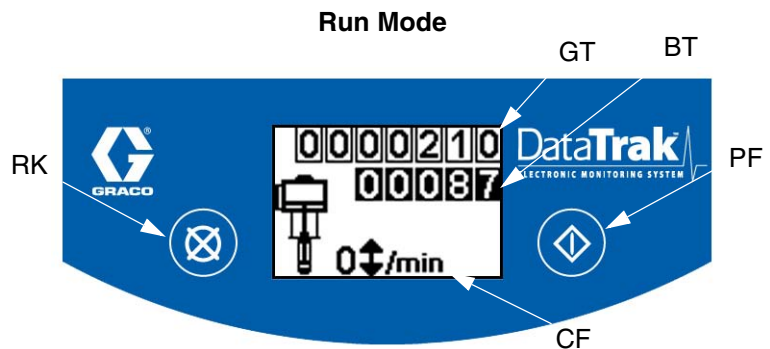
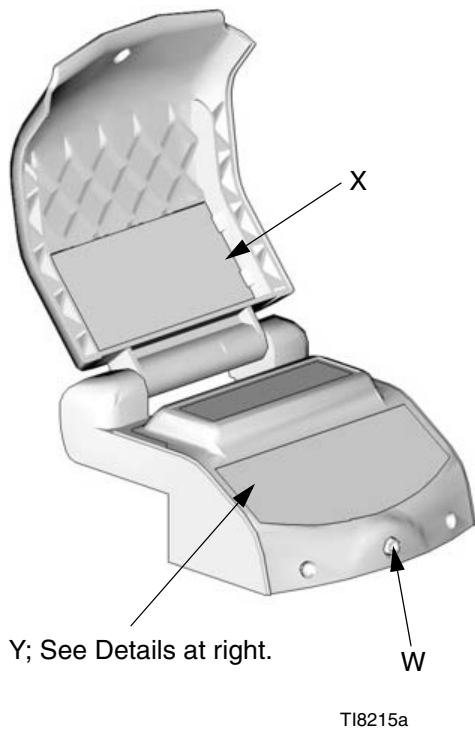





FIG. 5. DataTrak Controls and Indicators



# DataTrak Operation

 **NOTE:** To prevent damage to the DataTrak soft key buttons, do not press the buttons with sharp objects such as pens, plastic cards, or fingernails.

 **NOTE:** DataTrak is included with certain models. See Models, page 4, for a list of models featuring DataTrak.

 **NOTE:** The DataTrak display (Y) will turn off after 1 minute to save battery life. Press any key to wake up the display.

## Setup Mode

1. See FIG. 5. Press and hold  for 5 seconds until Setup menu appears.
2. To enter settings for runaway, lower size, and flow rate units, and to enable runaway, E1, E2, and E5 error options, press  to change the value, then  to save the value and move the cursor to the next data field.

 **NOTE:** When runaway, E1, E2, and E5 error options are enabled, a ✓ will appear on the setup screen. See FIG. 5.

3. Move the cursor to the E5 error enable option field, then press  once more to exit Setup mode.

## Run Mode

### Runaway

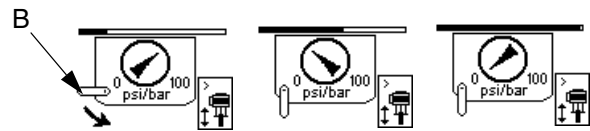

1. See FIG. 5. If pump runaway occurs, the runaway solenoid will actuate, stopping the pump. The LED (W) will flash and the display (Y) will indicate a runaway condition (see Table 3).
2. To reset runaway monitor, close master air valve (B). Wait for air to completely bleed off the air motor before going to step 3. The screen will change to indicate this, as shown below.

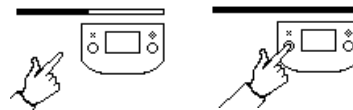

3. Press  to clear the diagnostic code and reset the runaway solenoid.





4. Open master air valve (B) to restart pump.

 **NOTE:** To disable runaway monitoring, go to setup mode and set runaway value (T) to 0 (zero) or disable (RT)  (see FIG. 5).

## Prime/Flush

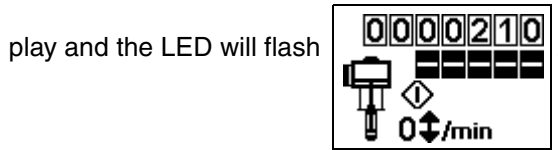

1. See FIG. 5. To enter Prime/Flush mode, press any key to wake up the display, then press . The Prime/Flush symbol will appear flashing in the display and the LED will flash



2. While in Prime/Flush mode, runaway protection is disabled and the batch totalizer (BT) will not count.
3. To exit Prime/Flush mode, press any key to wake up the display, then press . The Prime/Flush symbol will disappear from the display and the LED will stop flashing.

## Counter/Totalizer

See FIG. 5. The last digit of the batch totalizer (BT) represents tenths of gallons or liters. To reset the totalizer, press any key to wake up the display, then press and hold  for 3 seconds.

 **NOTE: If flow rate is set to  /min, both totalizers will display the number of pump cycles.**

## Display

See FIG. 5. The display (Y) will turn off after 1 minute of inactivity in Run mode or 3 minutes in Setup mode. Press any key to wake up the display.

 **NOTE: DataTrak will continue to count cycles when display is off.**

## Diagnostics

DataTrak can diagnose several problems with the pump. When the monitor detects a problem, the LED (W, FIG. 5) will flash and a diagnostic code will appear on the display. See Table 3.









To acknowledge the diagnosis and return to the normal operating screen, press  once to wake up the display, and once more to clear the diagnostic code screen.

Table 3: Diagnostic Codes

Symbol	Code	Code Name	Diagnosis	Cause
		Runaway	Pump running faster than set runaway limit.	<ul style="list-style-type: none"> <li>Increased air pressure.</li> <li>Increased fluid output.</li> <li>Exhausted fluid supply.</li> </ul>
	E-1	Diving Up	Leak during upstroke.	Worn piston valve or packings.
	E-2	Diving Down	Leak during downstroke.	Worn intake valve.
	E-3	Low Battery	Battery voltage too low to stop runaway.	Low battery. To replace battery, see manual 311238.
	E-4	Service Component 1	Problem with stopping runaway.	<ul style="list-style-type: none"> <li>Damaged solenoid.</li> <li>Damaged valve carriage.</li> </ul>
	E-4	Disconnected Solenoid	Solenoid is disconnected.	<ul style="list-style-type: none"> <li>Solenoid unplugged.</li> <li>Damaged solenoid wires.</li> </ul>
	E-5	Service Component 2	Problem with sensing valve movement.	<ul style="list-style-type: none"> <li>Sensors unplugged.</li> <li>Sensors mounted incorrectly.</li> <li>Damaged sensors.</li> <li>Damaged valve carriage.</li> </ul>
	E-6	Blown Fuse	Fuse is blown.	<ul style="list-style-type: none"> <li>Faulty solenoid or solenoid wiring.</li> <li>Extreme temperatures (above 140°F [60°C]).</li> </ul>

# Troubleshooting

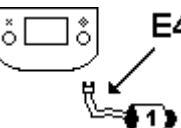

1. Follow **Pressure Relief Procedure**, page 13.
2. Check all possible causes and problems before disassembling pump.

Problem	Cause	Solution
Does not operate.	Valve closed or clogged.	Clear air line; increase air supply. Check that valves are open.
	Fluid hose or gun obstructed.	Clean hose or gun.*
	Dried fluid on displacement rod.	Clean rod; always stop pump at bottom of stroke; keep wet-cup filled with compatible solvent.
	Air motor parts dirty, worn, or damaged.	Clean or repair air motor. See motor manual.
	Runaway error on DataTrak tripped.	See <b>DataTrak Operation-Runaway</b> , page 20.
Output low on both strokes.	Air line restricted or air supply inadequate. Valves closed or clogged.	Clear air line; increase air supply. Check that valves are open.
	Fluid hose/gun obstructed; hose ID too small.	Clear hose or gun*; use hose with larger ID.
	Air motor icing.	Open De-Ice control; see page 11.
Output low on down stroke.	Open or worn intake valve.	Clear or service intake valve.
	High viscosity fluid.	Adjust intake spacers.
Output low on upstroke.	Open or worn piston valve or packings.	Clear piston valve; replace packings.
Erratic accelerated speed.	Fluid supply exhausted, clogged suction.	Refill supply and prime pump. Clean suction tube.
	High viscosity fluid.	Reduce viscosity; adjust intake spacers.
	Open or worn piston valve or packings.	Clear piston valve; replace packings.
	Open or worn intake valve.	Clear or service intake valve.
Runs sluggishly.	Possible icing.	Stop pump. Open De-Ice control; see page 11.
Cycles or fails to hold pressure at stall.	Worn check valves or seals.	Service lower. See <b>Xtreme Lower Removal</b> , page 24, and Xtreme Lower manual (311762).
Air bubbles in fluid.	Loose suction line.	Tighten. Use compatible liquid thread sealant or PTFE tape on connections.
Poor finish or irregular spray pattern.	Incorrect fluid pressure at gun.	See gun manual; read fluid manufacturer's recommendations.
	Fluid is too thin or too thick.	Adjust fluid viscosity; read fluid manufacturer's recommendations.
	Dirty, worn, or damaged spray gun.	Service spray gun. See spray gun manual.

\* To determine if fluid hose or gun is obstructed, follow **Pressure Relief Procedure**, page 13. Disconnect fluid hose and place a container at pump fluid outlet to catch any fluid. Turn on air power just enough to start pump. If pump starts, the obstruction is in fluid hose or gun.

# Xtreme Lower Removal

## Required Tools

- Set of adjustable wrenches
- Torque wrench
- Rubber mallet
- Thread lubricant
- Anti-seize lubricant 222955
- Loctite® 2760™ or equivalent

## Disconnect and Reconnect Lower

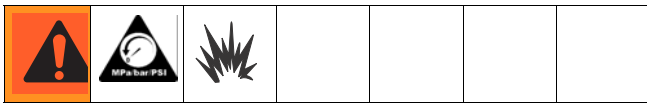

1. Flush pump; see **Prime/Flush**, page 14. Stop pump at bottom of its stroke. Follow **Pressure Relief Procedure**, page 13.
2. Tip cart back.

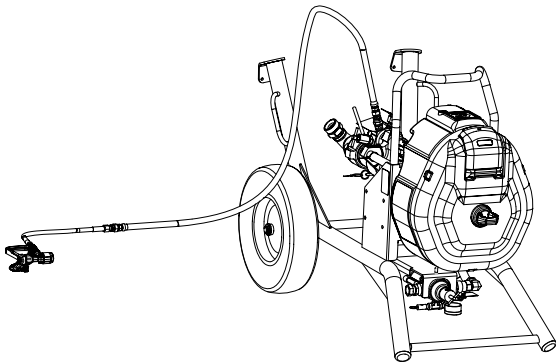

r\_x25dh1\_x45hd1\_311164\_24f

3. Disconnect air hose.

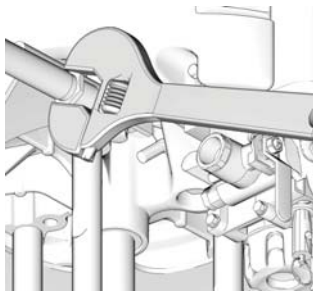

T18415a

4. Disconnect fluid hose (103). Disconnect suction hose (4). Hold fluid outlet fitting (6) with a wrench to keep it from loosening while you disconnect suction hose.

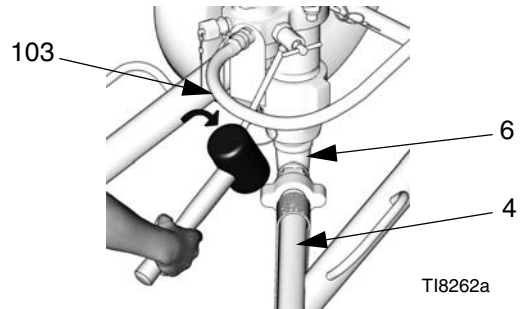

T18262a

Do not lift the pump by the lift ring when the total weight exceeds 250 kg (550 lb).						

<b>CAUTION</b>
Use caution when disconnecting lower; they can weigh up to 25 kg (55 lbs). Take appropriate precautions.

5. Note the relative position of lower's fluid outlet (P) to inlet (W) of motor for easier reassembly alignment. If motor does not require service, leave it attached to its mounting.

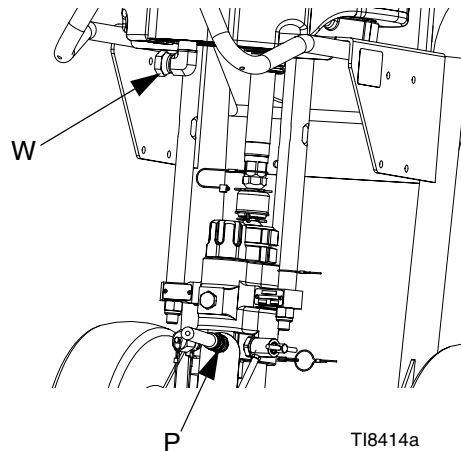

T18414a



6. Remove clip (309), and slide coupling cover (307) up to remove coupling (305).

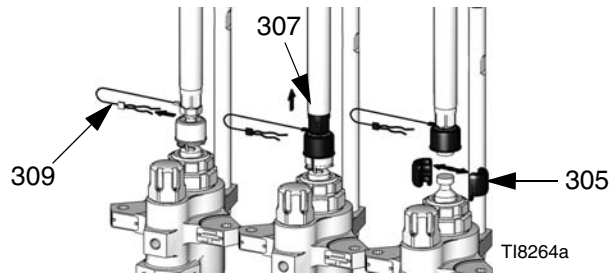

8. Refer to the Xtreme Lower manual (311762) to service lower. To service motor, refer to separate motor manual.
9. Reconnect lower by following disconnect steps in reverse order.

**NOTE:** Torque nuts (308) to 50-60 ft-lb (68-81 N•m).

7. Use a wrench to hold tie rod flats to keep rods (306) from turning. Unscrew nuts (308), and remove lower (302).

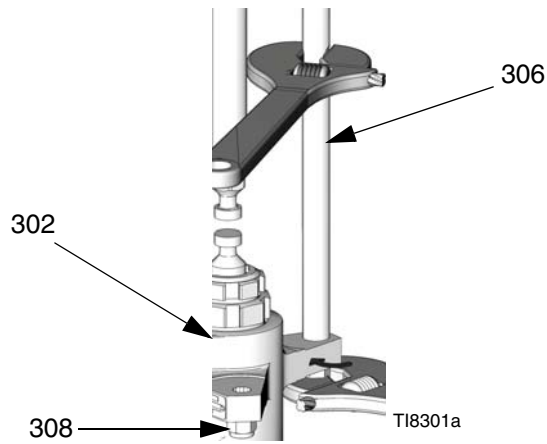

## Wall Mount Assembly

 **NOTE:** Before mounting any pump assembly to the wall always follow the Pressure Relief Procedure, page 13.

1. Ensure the wall is strong enough to support the weight of the pump assembly and accessories, fluid, hoses, and stress caused during pump operation.
2. Drill four 7/16 in. (11 mm) holes using bracket as a template. Use any of the three mounting hole groupings in the bracket. See **Pump Packages with L290C# Lowers (16:1, 25:1, 45:1 ratio)**, page 50.
3. Bolt bracket securely to wall using bolts and washers designed to hold in the wall's construction.
4. Attach pump assembly to mounting bracket (213).
5. Connect air and fluid hoses. Refer to **Setup**, page 12.

## Hopper Assembly

1. Hang hopper bracket (109b) on hose rack of sprayer cart.
2. Attach hanger bracket (109c) to hopper bracket (109b) using supplied bolts (109f) and nuts (109g).
3. Remove fitting supplied with hopper (109a) and replace with reducer (109n).
4. Hang hopper (109a) on bracket assembly. Adjust bracket assembly height as necessary.
5. Assemble fittings (109d, 109m, and 109e) to hopper.
6. Attach quick disconnect fitting (109m) to fluid inlet on pump lower.
7. Adjust bracket assembly height as necessary.

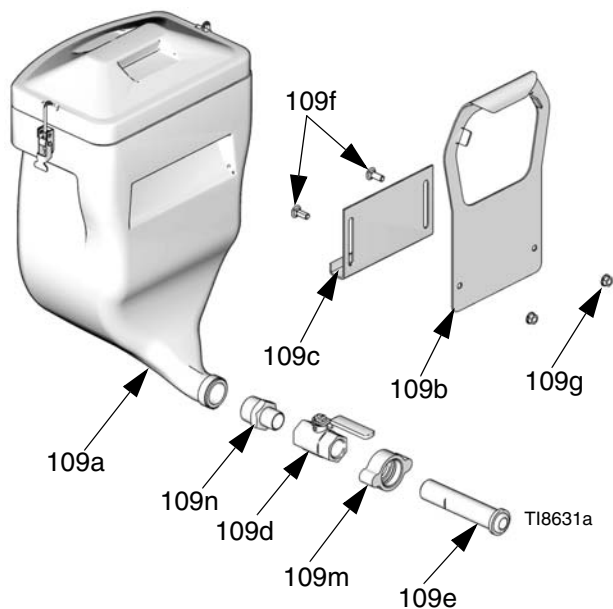



A series of horizontal lines for writing, consisting of 20 parallel lines spaced evenly down the page.

# Airless Xtreme Sprayer Parts

Complete Sprayer Shown (includes hose and gun)

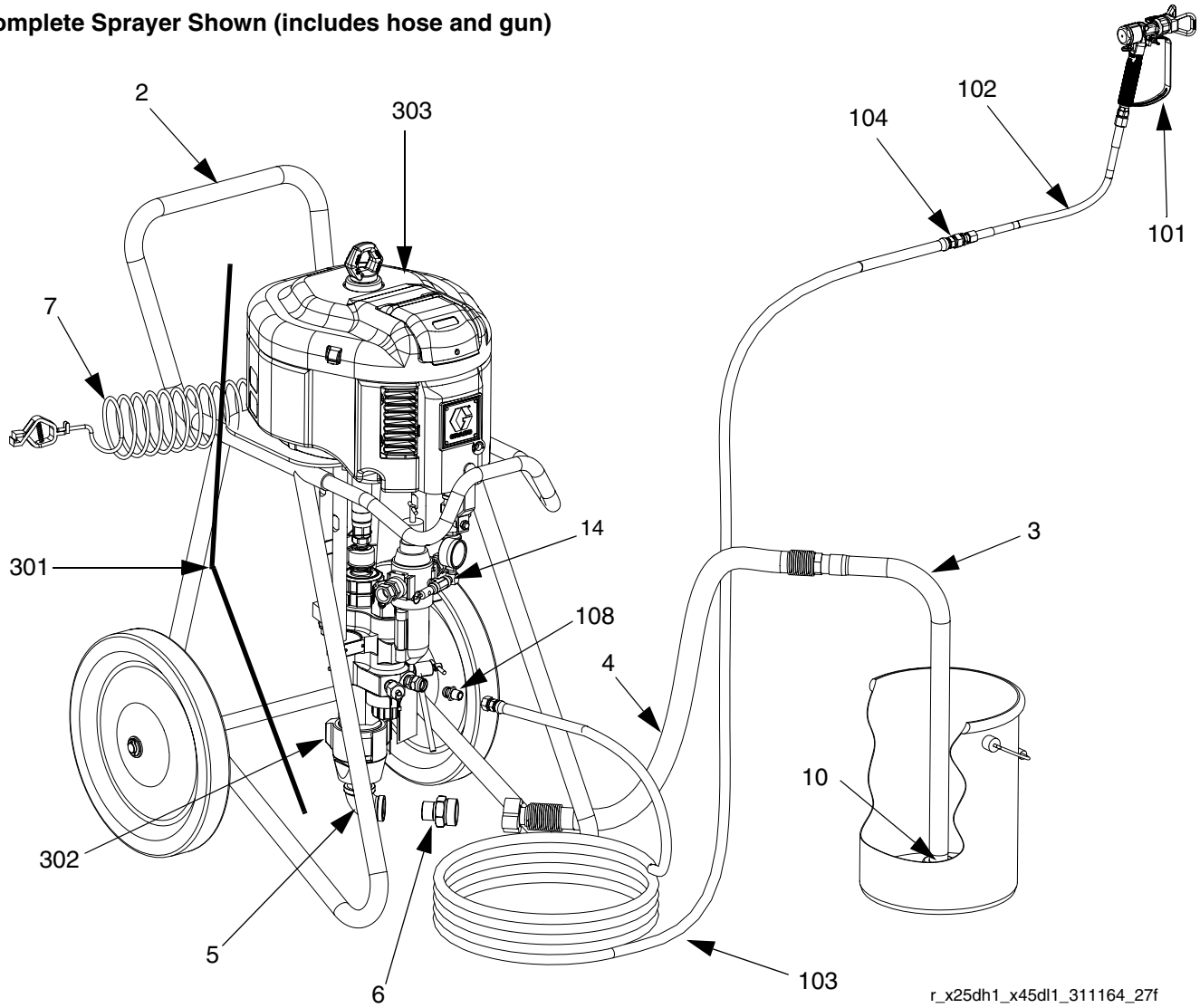

r\_x25dh1\_x45dl1\_311164\_27f

FIG. 6: X45DH1 Model Shown

# Wall Mount Xtreme Package Parts

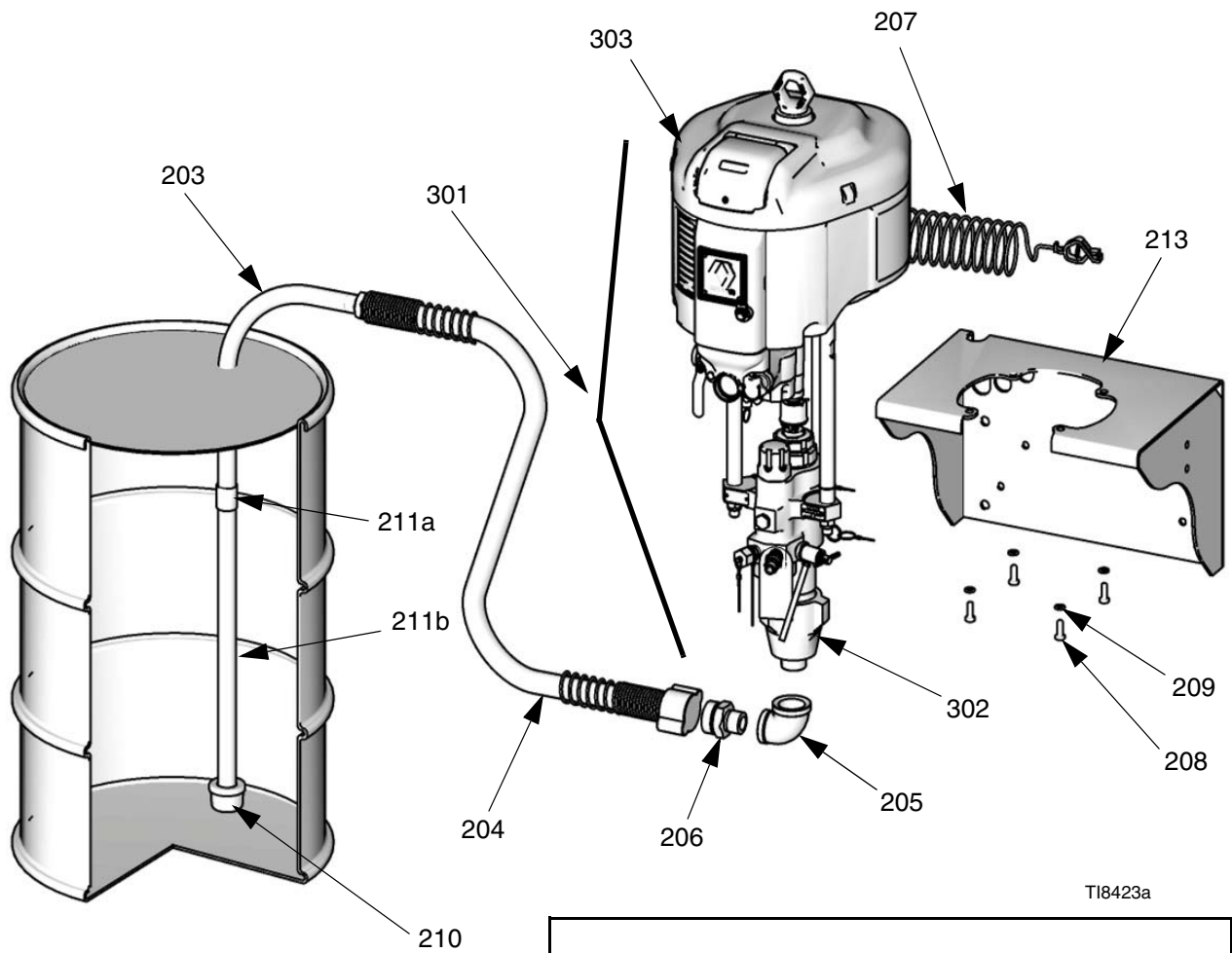

T18423a

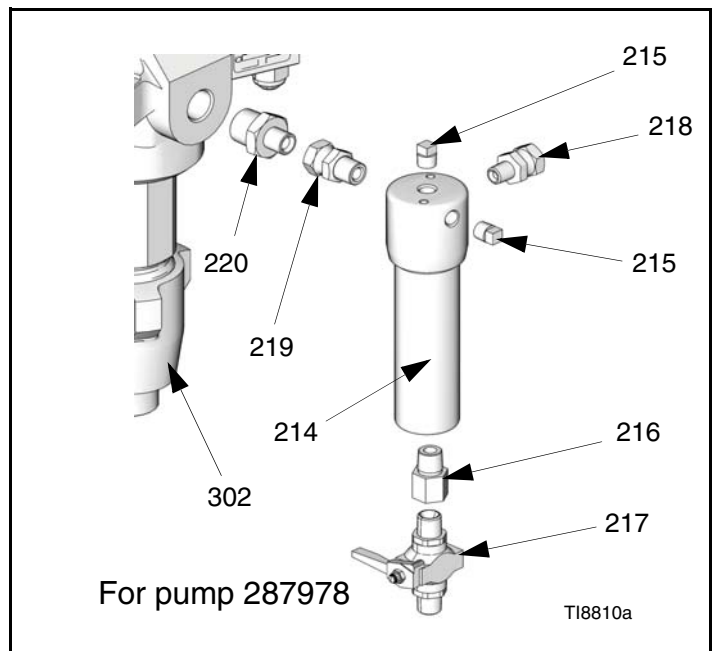

T18810a

FIG. 7: Wall Mount Package

## Parts - Airless Xtreme Sprayer Packages

The following table lists the major components and part numbers for each airless sprayer package. Refer to **Common Parts**, starting on page 35, for parts included with each airless sprayer package.

To determine your specific hopper option and package part number, see the key in **Hopper Options**, page 34.

### Component Parts - All Airless Sprayer Packages

Sprayer Package	Reference Number and Description		
	301	302	303
	Pump (see pg 43)	Lower (see 311762)	Motor (see 311238)
X25DH1	P25EC2	L290C2	N34DT0
X25DL1	P25EC2	L290C2	N34DT0
X25DH2	P25EC2	L290C2	N34DT0
X25DL2	P25EC2	L290C2	N34DT0
X25DW2	P25EC4	L290C2	N34DT0
X25DH3	P25DC2	L290C2	N34DN0
X25DL3	P25DC2	L290C2	N34DN0
X25DH4	P25DC2	L290C2	N34DN0
X25DL4	P25DC2	L290C2	N34DN0
X25DW4	P25DC4	L290C2	N34DN0
X25DH5	P25EC2	L290C2	N34DT0
X25DL5	P25EC2	L290C2	N34DT0
X25DH6	P25DC2	L290C2	N34DN0
X25DL6	P25DC2	L290C2	N34DN0
X30DH1	P30EC2	L220C2	N34DT0
X30DL1	P30EC2	L220C2	N34DT0
X30DH2	P30EC2	L220C2	N34DT0
X30DL2	P30EC2	L220C2	N34DT0
X30DW2	P30EC4	L220C2	N34DT0
X30DH3	P30DC2	L220C2	N34DN0
X30DL3	P30DC2	L220C2	N34DN0
X30DH4	P30DC2	L220C2	N34DN0
X30DL4	P30DC2	L220C2	N34DN0

Sprayer Package	Reference Number and Description		
	301	302	303
	Pump (see pg 43)	Lower (see 311762)	Motor (see 311238)
X30DW4	P30DC4	L220C2	N34DN0
X30DH5	P30EC2	L220C2	N34DT0
X30DL5	P30EC2	L220C2	N34DT0
X30DH6	P30DC2	L220C2	N34DN0
X30DL6	P30DC2	L220C2	N34DN0
X35DH1	P35EC2	L115C2	N22DT0
X35DL1	P35EC2	L115C2	N22DT0
X35DH2	P35EC2	L115C2	N22DT0
X35DL2	P35EC2	L115C2	N22DT0
X35DW2	P35EC4	L115C2	N22DT0
X35DH3	P35DC2	L115C2	N22DN0
X35DL3	P35DC2	L115C2	N22DN0
X35DH4	P35DC2	L115C2	N22DN0
X35DL4	P35DC2	L115C2	N22DN0
X35DW4	P35DC4	L115C2	N22DN0
X35DH5	P35EC2	L115C2	N22DT0
X35DL5	P35EC2	L115C2	N22DT0
X35DH6	P35DC2	L115C2	N22DN0
X35DL6	P35DC2	L115C2	N22DN0
X40DH1	P40EC2	L180C2	N34DT0
X40DL1	P40EC2	L180C2	N34DT0
X40DH2	P40EC2	L180C2	N34DT0
X40DL2	P40EC2	L180C2	N34DT0
X40DW2	P40EC4	L180C2	N34DT0
X40DH3	P40DC2	L180C2	N34DN0

Sprayer Package	Reference Number and Description		
	301	302	303
	Pump (see pg 43)	Lower (see 311762)	Motor (see 311238)
X40DL3	P40DC2	L180C2	N34DN0
X40DH4	P40DC2	L180C2	N34DN0
X40DL4	P40DC2	L180C2	N34DN0
X40DW4	P40DC4	L180C2	N34DN0
X40DH5	P40EC2	L180C2	N34DT0
X40DL5	P40EC2	L180C2	N34DT0
X40DH6	P40DC2	L180C2	N34DN0
X40DL6	P40DC2	L180C2	N34DN0
X45DH1	P45EC2	L290C2	N65DT0
X45DL1	P45EC2	L290C2	N65DT0
X45DH2	P45EC2	L290C2	N65DT0
X45DL2	P45EC2	L290C2	N65DT0
X45DW2	P45EC4	L290C2	N65DT0
X45DH3	P45DC2	L290C2	N65DN0
X45DL3	P45DC2	L290C2	N65DN0
X45DH4	P45DC2	L290C2	N65DN0
X45DL4	P45DC2	L290C2	N65DN0
X45DW4	P45DC4	L290C2	N65DN0
X45DH5	P45EC2	L290C2	N65DT0
X45DL5	P45EC2	L290C2	N65DT0
X45DH6	P45DC2	L290C2	N65DN0
X45DL6	P45DC2	L290C2	N65DN0
X45LH1	P45MC2	L290C2	N65LT0
X45LL1	P45MC2	L290C2	N65LT0
X45LH2	P45MC2	L290C2	N65LT0
X45LL2	P45MC2	L290C2	N65LT0
X45LW2	P45MC4	L290C2	N65LT0
X45LH3	P45LC2	L290C2	N65LN0
X45LL3	P45LC2	L290C2	N65LN0

Sprayer Package	Reference Number and Description		
	301	302	303
	Pump (see pg 43)	Lower (see 311762)	Motor (see 311238)
X45LH4	P45LC2	L290C2	N65LN0
X45LL4	P45LC2	L290C2	N65LN0
X45LW4	P45LC4	L290C2	N65LN0
X45LH5	P45MC2	L290C2	N65LT0
X45LL5	P45MC2	L290C2	N65LT0
X45LH6	P45LC2	L290C2	N65LN0
X45LL6	P45LC2	L290C2	N65LN0
X46DH1	P46EC2	L145C2	N34DT0
X46DL1	P46EC2	L145C2	N34DT0
X46DH2	P46EC2	L145C2	N34DT0
X46DL2	P46EC2	L145C2	N34DT0
X46DW2	P46EC4	L145C2	N34DT0
X46DH3	P46DC2	L145C2	N34DN0
X46DL3	P46DC2	L145C2	N34DN0
X46DH4	P46DC2	L145C2	N34DN0
X46DL4	P46DC2	L145C2	N34DN0
X46DW4	P46DC4	L145C2	N34DN0
X46DH5	P46EC2	L145C2	N34DT0
X46DL5	P46EC2	L145C2	N34DT0
X46DH6	P46DC2	L145C2	N34DN0
X46DL6	P46DC2	L145C2	N34DN0
X50DH1	P50EC2	L250C2	N65DT0
X50DL1	P50EC2	L250C2	N65DT0
X50DH2	P50EC2	L250C2	N65DT0
X50DL2	P50EC2	L250C2	N65DT0
X50DW2	P50EC4	L250C2	N65DT0
X50DH3	P50DC2	L250C2	N65DN0
X50DL3	P50DC2	L250C2	N65DN0
X50DH4	P50DC2	L250C2	N65DN0
X50DL4	P50DC2	L250C2	N65DN0

Sprayer Package	Reference Number and Description		
	301	302	303
	Pump (see pg 43)	Lower (see 311762)	Motor (see 311238)
X50DW4	P50DC4	L250C2	N65DN0
X50DH5	P50EC2	L250C2	N65DT0
X50DL5	P50EC2	L250C2	N65DT0
X50DH6	P50DC2	L250C2	N65DN0
X50DL6	P50DC2	L250C2	N65DN0
X50LH1	P50MC2	L250C2	N65LT0
X50LL1	P50MC2	L250C2	N65LT0
X50LH2	P50MC2	L250C2	N65LT0
X50LL2	P50MC2	L250C2	N65LT0
X50LW2	P50MC4	L250C2	N65LT0
X50LH3	P50LC2	L250C2	N65LN0
X50LL3	P50LC2	L250C2	N65LN0
X50LH4	P50LC2	L250C2	N65LN0
X50LL4	P50LC2	L250C2	N65LN0
X50LW4	P50LC4	L250C2	N65LN0
X50LH5	P50MC2	L250C2	N65LT0
X50LL5	P50MC2	L250C2	N65LT0
X50LH6	P50LC2	L250C2	N65LN0
X50LL6	P50LC2	L250C2	N65LN0
X55DH1	P55EC2	L115C2	N34DT0
X55DL1	P55EC2	L115C2	N34DT0
X55DH2	P55EC2	L115C2	N34DT0
X55DL2	P55EC2	L115C2	N34DT0
X55DW2	P55EC4	L115C2	N34DT0
X55DH3	P55DC2	L115C2	N34DN0
X55DL3	P55DC2	L115C2	N34DN0
X55DH4	P55DC2	L115C2	N34DN0
X55DL4	P55DC2	L115C2	N34DN0
X55DW4	P55DC4	L115C2	N34DN0
X55DH5	P55EC2	L115C2	N34DT0

Sprayer Package	Reference Number and Description		
	301	302	303
	Pump (see pg 43)	Lower (see 311762)	Motor (see 311238)
X55DL5	P55EC2	L115C2	N34DT0
X55DH6	P55DC2	L115C2	N34DN0
X55DL6	P55DC2	L115C2	N34DN0
X60DH1	P60EC2	L220C2	N65DT0
X60DL1	P60EC2	L220C2	N65DT0
X60DH2	P60EC2	L220C2	N65DT0
X60DL2	P60EC2	L220C2	N65DT0
X60DW2	P60EC4	L220C2	N65DT0
X60DH3	P60DC2	L220C2	N65DN0
X60DL3	P60DC2	L220C2	N65DN0
X60DH4	P60DC2	L220C2	N65DN0
X60DL4	P60DC2	L220C2	N65DN0
X60DW4	P60DC4	L220C2	N65DN0
X60DH5	P60EC2	L220C2	N65DT0
X60DL5	P60EC2	L220C2	N65DT0
X60DH6	P60DC2	L220C2	N65DN0
X60DL6	P60DC2	L220C2	N65DN0
X60LH1	P60MC2	L220C2	N65LT0
X60LL1	P60MC2	L220C2	N65LT0
X60LH2	P60MC2	L220C2	N65LT0
X60LL2	P60MC2	L220C2	N65LT0
X60LW2	P60MC4	L220C2	N65LT0
X60LH3	P60LC2	L220C2	N65LN0
X60LL3	P60LC2	L220C2	N65LN0
X60LH4	P60LC2	L220C2	N65LN0
X60LL4	P60LC2	L220C2	N65LN0
X60LW4	P60LC4	L220C2	N65LN0
X60LH5	P60MC2	L220C2	N65LT0
X60LL5	P60MC2	L220C2	N65LT0



Sprayer Package	Reference Number and Description		
	301	302	303
	Pump (see pg 43)	Lower (see 311762)	Motor (see 311238)
X60LH6	P60LC2	L220C2	N65LN0
X60LL6	P60LC2	L220C2	N65LN0
X70DH1	P70EC2	L180C2	N65DT0
X70DL1	P70EC2	L180C2	N65DT0
X70DH2	P70EC2	L180C2	N65DT0
X70DL2	P70EC2	L180C2	N65DT0
X70DW2	P70EC4	L180C2	N65DT0
X70DH3	P70DC2	L180C2	N65DN0
X70DL3	P70DC2	L180C2	N65DN0
X70DH4	P70DC2	L180C2	N65DN0
X70DL4	P70DC2	L180C2	N65DN0
X70DW4	P70DC4	L180C2	N65DN0
X70DH5	P70EC2	L180C2	N65DT0
X70DL5	P70EC2	L180C2	N65DT0
X70DH6	P70DC2	L180C2	N65DN0
X70DL6	P70DC2	L180C2	N65DN0
X70LH1	P70MC2	L180C2	N65LT0
X70LL1	P70MC2	L180C2	N65LT0
X70LH2	P70MC2	L180C2	N65LT0
X70LL2	P70MC2	L180C2	N65LT0
X70LW2	P70MC4	L180C2	N65LT0
X70LH3	P70LC2	L180C2	N65LN0
X70LL3	P70LC2	L180C2	N65LN0
X70LH4	P70LC2	L180C2	N65LN0
X70LL4	P70LC2	L180C2	N65LN0
X70LW4	P70LC4	L180C2	N65LN0
X70LH5	P70MC2	L180C2	N65LT0
X70LL5	P70MC2	L180C2	N65LT0
X70LH6	P70LC2	L180C2	N65LN0
X70LL6	P70LC2	L180C2	N65LN0

Sprayer Package	Reference Number and Description		
	301	302	303
	Pump (see pg 43)	Lower (see 311762)	Motor (see 311238)
X80DH1	P80EC2	L085C2	N34DT0
X80DL1	P80EC2	L085C2	N34DT0
X80DH2	P80EC2	L085C2	N34DT0
X80DL2	P80EC2	L085C2	N34DT0
X80DW2	P80EC4	L085C2	N34DT0
X80DH3	P80DC2	L085C2	N34DN0
X80DL3	P80DC2	L085C2	N34DN0
X80DH4	P80DC2	L085C2	N34DN0
X80DL4	P80DC2	L085C2	N34DN0
X80DW4	P80DC4	L085C2	N34DN0
X80DH5	P80EC2	L085C2	N34DT0
X80DL5	P80EC2	L085C2	N34DT0
X80DH6	P80DC2	L085C2	N34DN0
X80DL6	P80DC2	L085C2	N34DN0
X90DH1	P90EC2	L145C2	N65DT0
X90DL1	P90EC2	L145C2	N65DT0
X90DH2	P90EC2	L145C2	N65DT0
X90DL2	P90EC2	L145C2	N65DT0
X90DW2	P90EC4	L145C2	N65DT0
X90DH3	P90DC2	L145C2	N65DN0
X90DL3	P90DC2	L145C2	N65DN0
X90DH4	P90DC2	L145C2	N65DN0
X90DL4	P90DC2	L145C2	N65DN0
X90DW4	P90DC4	L145C2	N65DN0
X90DH5	P90EC2	L145C2	N65DT0
X90DL5	P90EC2	L145C2	N65DT0
X90DH6	P90DC2	L145C2	N65DN0
X90DL6	P90DC2	L145C2	N65DN0

Sprayer Package	Reference Number and Description		
	301	302	303
	Pump (see pg 43)	Lower (see 311762)	Motor (see 311238)
X90LH1	P90MC2	L145C2	N65LT0
X90LL1	P90MC2	L145C2	N65LT0
X90LH2	P90MC2	L145C2	N65LT0
X90LL2	P90MC2	L145C2	N65LT0
X90LW2	P90MC4	L145C2	N65LT0
X90LH3	P90LC2	L145C2	N65LN0
X90LL3	P90LC2	L145C2	N65LN0
X90LH4	P90LC2	L145C2	N65LN0
X90LL4	P90LC2	L145C2	N65LN0
X90LW4	P90LC4	L145C2	N65LN0
X90LH5	P90MC2	L145C2	N65LT0
X90LL5	P90MC2	L145C2	N65LT0
X90LH6	P90LC2	L145C2	N65LN0
X90LL6	P90LC2	L145C2	N65LN0

## Hopper Options

If your sprayer package includes a hopper, use the following table to determine the specific hopper option. For example, X60DH5 indicates the airless sprayer package includes a hopper, gun, hose, and DataTrak.

Digit 6	Option
5	Hopper Package; complete package with DataTrak
6	Hopper Package; complete package without DataTrak

## Motor Key

<b>First Digit</b>	Motor	N (NXT Air Motor)
<b>Second and Third Digits</b>	cc per stroke	65 = 6500 34 = 3400 22 = 2200
<b>Fourth Digit</b>	Exhaust Type	D = De-icing L = Low noise R = Remote
<b>Fifth Digit</b>	Data Monitoring	N = None T = DataTrak H = High level linear sensor
<b>Sixth Digit</b>	Unassigned	0 = Non assigned

## Common Parts

### Airless Sprayer Packages

The following parts are included with each airless sprayer package:

Ref.	Part	Description	Qty.
2		CART	1
	287884	Heavy duty (H); see pg. 39	
	287919	Light weight (L); see pg. 39	
3	197682	TUBE, suction	1
4	247301	HOSE, suction, 1 in., NPT x quick connect, 6 ft.	1
5	116401	ADAPTER, elbow	1
6	116402	ADAPTER, quick connect	1
7	244524	WIRE, ground assy. w/ clamp	1
10	181072	INLET, strainer	1
11*	100101	SCREW, mounting, cap, hex head	4
12*	100133	WASHER, lock	4
13♦	247312	PLATE, adapter kit (includes 13a-13b) for NXT 2200 Air Motors	1
13a*		NUT, lock	4
13b*		PLATE, adapter	1
14		AIR CONTROLS	1
	24E013	CONTROL, air, heavy duty cart; see manual 3A0293	
	24E025	CONTROL, air, light duty cart; see manual 3A0293	

♦ X35\*\*\* models only.

\* Not shown.

The following parts are included with only complete airless sprayer packages:

Ref.	Part	Description	Qty.
101		GUN, spray	1
	XTR504	XTR5 spray gun for models with 25:1 - 50:1 ratio only	
	XTR704	XTR7 spray gun for models with 55:1 - 90:1 ratio only	
102		HOSE, fluid; nylon; 1/4 in. ID, 1/4 npsm(fbe); 6 ft.	1
	H42506	Models with 25:1 - 45:1 ratio	
	H52506	Models with 46:1 - 55:1 ratio	
	H72506	Models with 60:1 - 90:1 ratio	
103		HOSE, fluid; nylon, 3/8 in. ID; 3/8 npsm(fbe); 50 ft.	1
	H43850	Models with 25:1 - 45:1 ratio	
	H53850	Models with 46:1 - 55:1 ratio	
	H73850	Models with 60:1 - 90:1 ratio	
104	164856	FITTING, nipple, reducing; 3/8 x 1/4 npt(m)	1
108	162505	FITTING, union, swivel; 1/2 in. F x 3/8 in. M	1

### Airless Sprayers with Hopper Packages

Hopper kit is shown on page 26.

Ref.	Part	Description	Qty.
2		CART	1
	287884	Heavy duty (H); see pg. 39	
	287919	Light weight (L); see pg. 39	
5	116401	ADAPTER, elbow	1
6	116402	ADAPTER, quick connect	1
7	244524	WIRE, ground assy. w/ clamp	1
11*	100101	SCREW, mounting, cap, hex head	4
12*	100133	WASHER, lock	4
14		AIR CONTROLS	1
	24E013	CONTROL, air, heavy duty cart; see manual 3A0293	
	24E025	CONTROL, air, light duty cart; see manual 3A0293	
101		GUN, spray	1
	XTR504	XTR5 spray gun for models with 25:1 - 50:1 ratio only	
	XTR704	XTR7 spray gun for models with 55:1 - 90:1 ratio only	
102		HOSE, fluid; nylon; 1/4 in. ID, 1/4 npsm(fbe); 6 ft.	1
	H42506	Models with 25:1 - 45:1 ratio	
	H52506	Models with 46:1 - 55:1 ratio	
	H72506	Models with 60:1 - 90:1 ratio	
103		HOSE, fluid; nylon, 3/8 in. ID; 3/8 npsm(fbe); 50 ft.	1
	H43850	Models with 25:1 - 45:1 ratio	
	H53850	Models with 46:1 - 55:1 ratio	
	H73850	Models with 60:1 - 90:1 ratio	
104	164856	FITTING, NIPPLE, reducing; 3/8 x 1/4 npt(m)	1
108	162505	FITTING, union, swivel; 1/2 in. F x 3/8 in. M	1
109	288347	HOPPER, kit (includes a - n)	1
109a		HOPPER, fluid	1
109b		BRACKET, hopper	1
109c		BRACKET, hanger, hopper	1
109d		VALVE, ball	1
109e		FITTING, connection, hopper	1
109f		SCREW, cap, hex head	2
109g		NUT, hex, flanged	2
109m		NUT, wing	1
109n		FITTING, NIPPLE, reducing	1
110♦	247312	PLATE, adapter kit (includes a-b) for NXT 2200 Air Motors	1
	110a*	NUT, lock	4
	110b*	PLATE, adapter	1

♦ X35\*\*\* models only.

\* Not shown.

**Wall Mount Packages**

Ref.	Part	Description	Qty.
203	197682	TUBE, suction	1
204	247302	HOSE, suction, 1 in., NPT x quick connect; 10 ft.	1
205	116401	ADAPTER, elbow	1
206	116402	ADAPTER, quick connect	1
207	244524	WIRE, ground assy. w/clamp	1
208	100101	SCREW, mounting, cap, hex head	4
209	100133	WASHER, lock	4
210	181072	INLET, strainer	1
211	245136	TUBE, intake extension (includes 211a-211b)	1
211a		COUPLING, pipe, 1 in.	1
211b		TUBE, intake	1
213	255143	BRACKET (W), mounting (includes 208-209)	1
214◆	247312	PLATE, adapter kit (includes 214a-214b) for NXT 2200 Air Motors	1
214a*		NUT, lock	4
214b*		PLATE, adapter	1

◆ X35\*\*\* models only.

\* Not shown.

**Wall Mount Package 287978**

Ref.	Part	Description	Qty.
203	197682	TUBE, suction	1
204	247302	HOSE, suction, 1 in., NPT x quick connect; 10 ft.	1
205	116401	ADAPTER, elbow	1
206	116402	ADAPTER, quick connect	1
207	244524	WIRE, ground assy. w/clamp	1
208	100101	SCREW, mounting, cap, hex head	4
209	100133	WASHER, lock	4
210	181072	INLET, strainer	1
211	245136	TUBE, intake extension (includes 211a-211b)	1
211a		COUPLING, pipe, 1 in.	1
211b		TUBE, intake	1
213	255143	BRACKET (W), mounting (includes 208-209)	1
214	218029	FILTER, fluid	1
215	100509	PLUG, pipe	2
216	150286	ADAPTER, 2 x 3/8-18 NPT	1
217	210658	VALVE, ball	1
218	157705	UNION, swivel, 3/8-18 npsm x 1/4-18 NPT	1
219	155665	UNION, adapter, 3/8-18 npsm x 3/8-18 NPT	1
220	161800	ADAPTER, 3/4 x 3/8 mbe	1
301	P40MC3	PUMP	1

 **NOTE: Wall Mount Package parts are shown on page 29.**

# Air-Assisted Xtreme Sprayer Parts

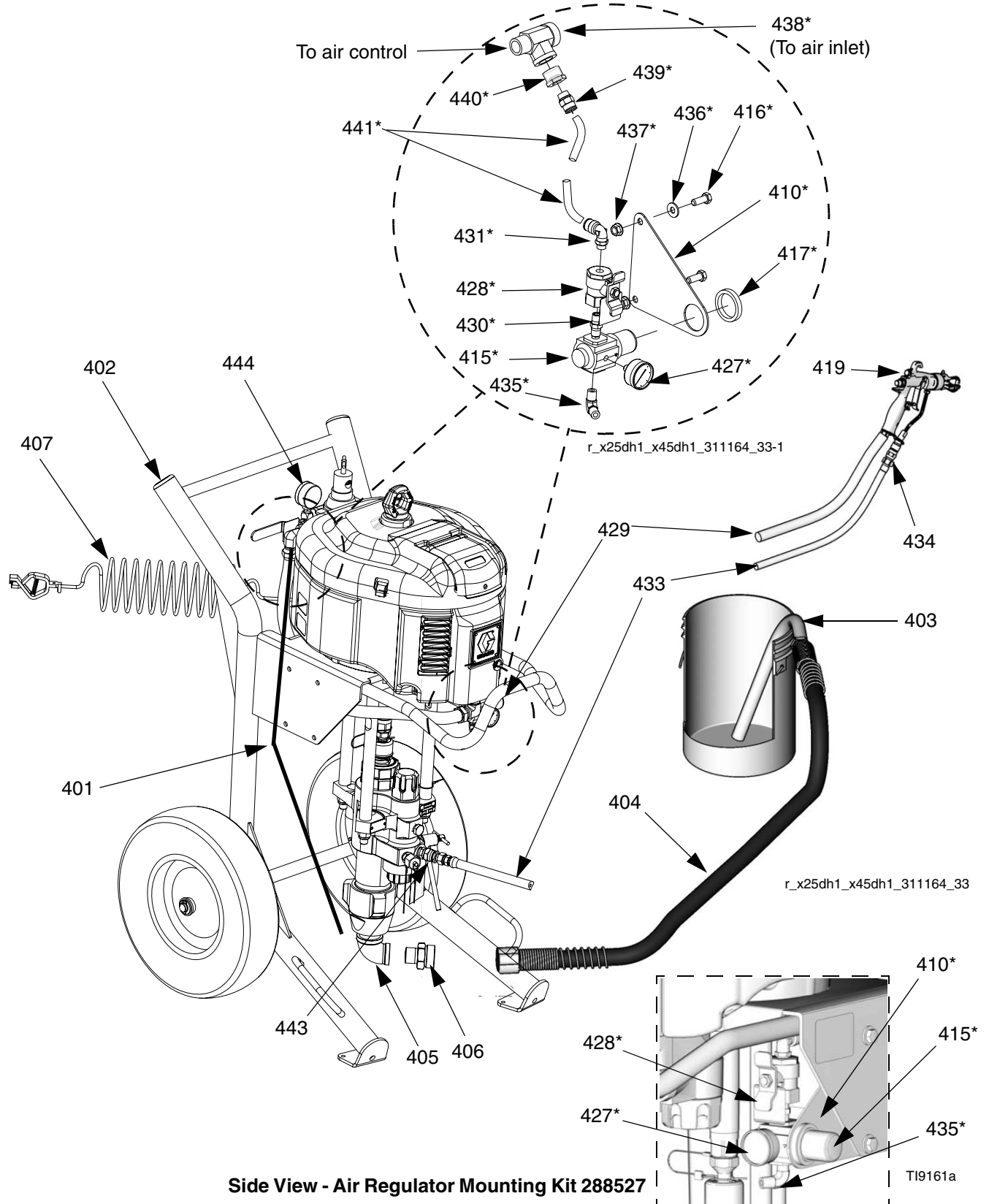

Side View - Air Regulator Mounting Kit 288527

FIG. 8: Model 287976

# Zinc Xtreme Sprayer Parts

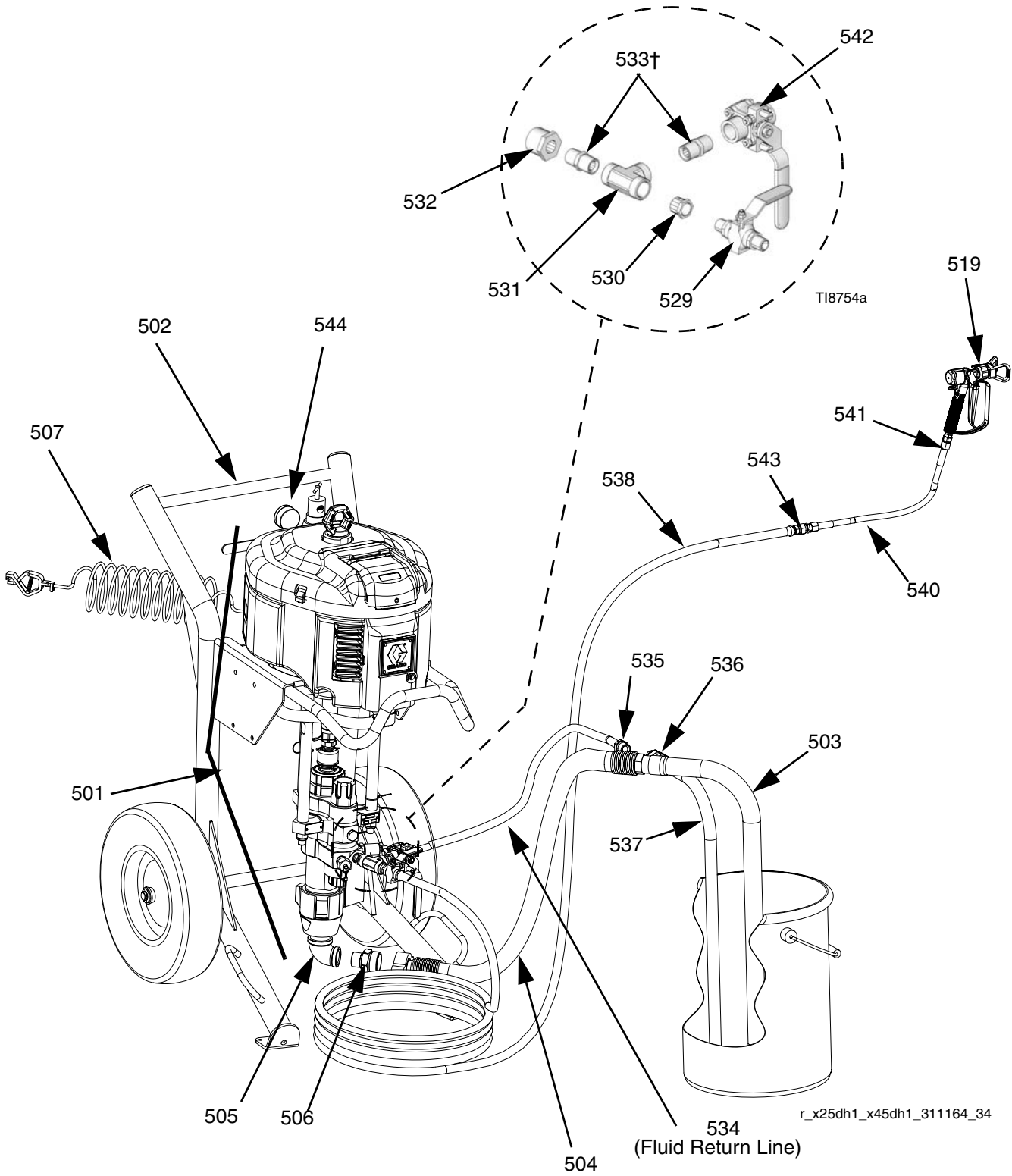

FIG. 9: Model 287973 Shown

# Parts - Air-Assisted and Zinc Sprayer Packages

## Air-Assisted Sprayer Packages

Models 287975 and 287976

Ref.	Part	Description	Qty.
401	P30EC2	PUMP, assy. 287975	1
	P40EC2	PUMP, assy. 287976	1
402	287884	CART, heavy duty; see pg. 39	1
403	197682	TUBE, suction	1
404	247301	HOSE, suction, 1 in., NPT x quick connect, 6 ft.	1
405	116401	ADAPTER, elbow	1
406	116402	ADAPTER, quick connect	1
407	244524	WIRE, ground assembly w/ clamp	1
410*	288523	BRACKET, air controls	1
415*	116513	REGULATOR, air, gun	1
416*	100101	SCREW, mounting, cap, hex hd	6
417*	116514	NUT, regulator mount	1
418*	100133	WASHER, lock	4
419	24C857	GUN, spray	1
427*	108190	GAUGE, pressure, gun	1
428*	116473	VALVE, ball, vented, 2 way	1
429	210868	HOSE, air, coupled, 50 ft.	1
430*	156971	NIPPLE, short	1
431*	114128	ELBOW, male, swivel	1
433	H52550	HOSE, fluid; nylon, 1/4 in. ID; 1/4 npsm(fbe); 50 ft.	1
434	189018	SWIVEL	1
435*	111763	ELBOW, 1/4 npt	1
436*	100023	WASHER, flat	2
437*	112958	NUT, hex, flanged	2
438*	111337	FITTING, tee, street	1
439*	114129	CONNECTOR, male	1
440*	100505	BUSHING, pipe	1
441*		TUBE	1
443	159842	ADAPTER, bushing, 1/4 npt(m) x 1/2 npt(f)	1
444	24E013	CONTROLS, air, heavy duty cart	1

\* Not shown.

\* Included in Air Regulator Mounting Kit 288527.

## Zinc Sprayer Packages

Models 287971, 287972, 287973, 287974

Ref.	Part	Description	Qty.
501	P25DC1	PUMP, assy. 287971 and 287973	1
	P40DC1	PUMP, assy. 287972 and 287974	1
502	287884	CART, heavy duty; see pg. 39	1
503	197682	TUBE, suction	1
504	247301	HOSE, suction, 1 in., NPT x quick connect, 6 ft.	1
505	116401	ADAPTER, elbow	1
506	116402	ADAPTER, quick connect	1
507	244524	WIRE, ground assembly w/ clamp	1
516*	100101	SCREW, mounting, cap, hex hd	4
518*	100133	WASHER, lock	4
519✓	238591	GUN, spray	1
529	238612	VALVE, ball	1
530	100081	BUSHING, pipe	1
531	103475	FITTING, tee, pipe	1
532		BUSHING, pipe	1
	100380	Model 287973	1
	157191	Model 287974	1
533†	158491	FITTING, nipple	1
534	235148	HOSE, coupled, 6 ft	1
535	100896	FITTING, bushing, pipe	1
536	157785	FITTING, swivel	1
537	165767	TUBE, suction	1
538✓	H43850	HOSE, fluid; nylon, 3/8 in. ID; 3/8 npsm(fbe); 50 ft.	1
540✓	H42506	HOSE, fluid; nylon; 1/4 in. ID, 1/4 npsm(fbe); 6 ft.	1
541✓	189018	FITTING, swivel, 1/4-18 npsm(f) x 1/4-18 npsm(m)	1
542	102646	VALVE, ball	1
543✓	164856	FITTING, nipple, reducing; 3/8 x 1/4 npt(m)	1
544	24E013	CONTROLS, air, heavy duty cart	1

\* Not shown.

† Quantity of two for Models 287971 and 287973;  
quantity of one for Models 287972 and 287974.

✓ Models 287973 and 287974 only.

# Dura-Flo Sprayer Parts

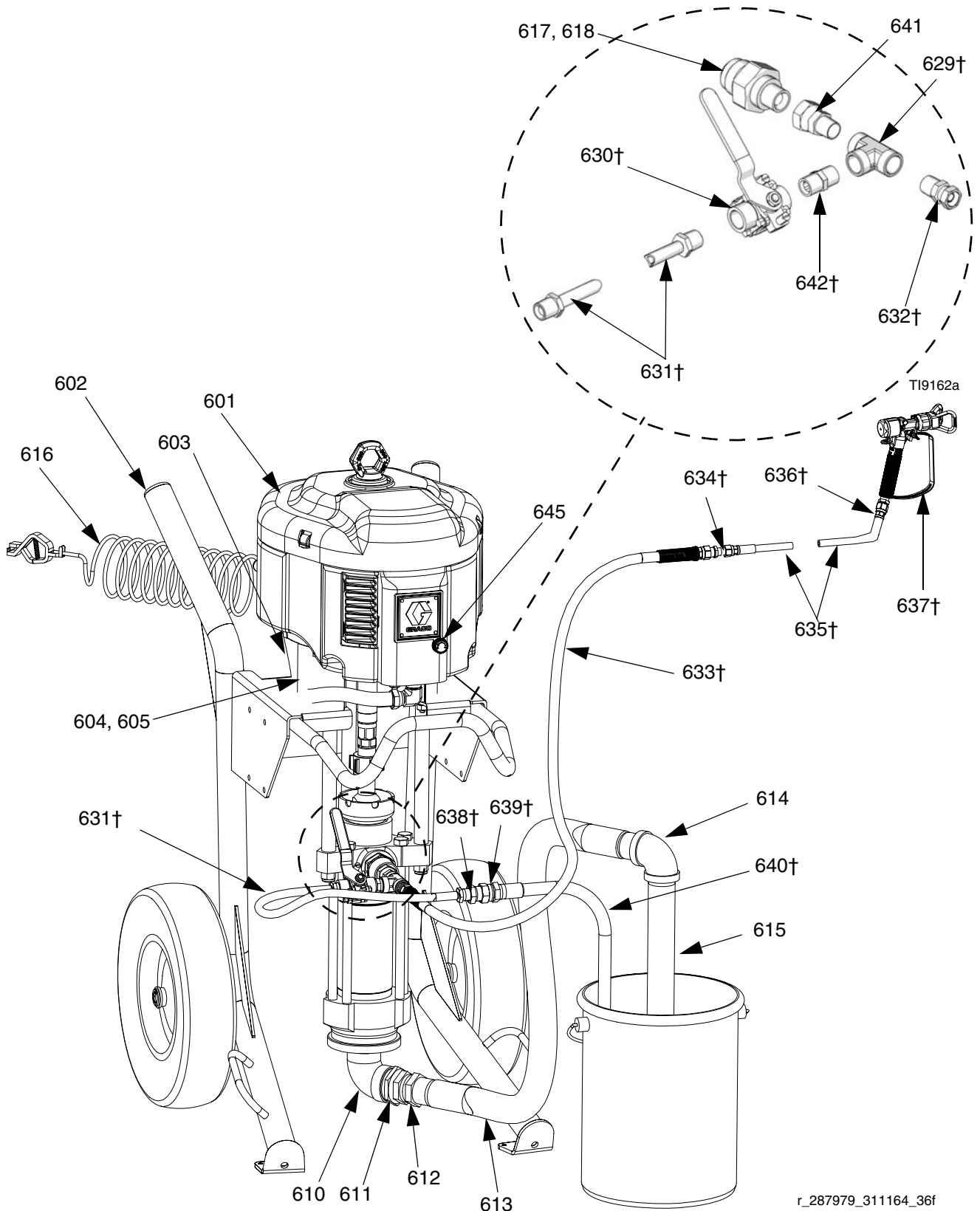

FIG. 10: Model 287980

r\_287979\_311164\_36f



# Parts - Dura-Flo Sprayer Packages

## Model 287979, 287980, and 287981



**NOTE: Model 287980 is the only model that includes a gun and hose.**

Ref.	Part	Description	Qty.	Ref.	Part	Description	Qty.
601	P23DCD	PUMP, Dura-Flo,6500/580	1	629†	103475	FITTING, tee, pipe	1
	★P32DCD	PUMP, Dura-Flo, 6500/430	1	630†	102646	VALVE, ball	1
602	287884	CART, heavy duty, see pg. 42	1	631†	235148	HOSE, coupled, 6 ft	1
603	24E013	CONTROL, air, heavy duty cart; see manual 3A0293	1	632†	158256	UNION, swivel	1
604	15K296	SPACER	1	633†	240797	HOSE, coupled, 3/8 x 50	1
605*	120465	SPACER, mounting, threaded	4	634†	164856	FITTING, nipple, reducing	1
606*	100133	WASHER, lock	4	635†	239984	HOSE, coupled, 1/4 in. x 25	1
610	100088	ELBOW, street, pipe, 90 degrees	1	636†	189018	SWIVEL, 5800 psi	1
611	109505	BUSHING	1	637†	238591	GUN, spray	1
612	113864	UNION, swivel,1 1/2 npt	1	638†	100896	FITTING, bushing, pipe	1
613	222914	HOSE, coupled	1	639†	157785	FITTING, swivel	1
614	109475	ELBOW, pipe, female, 90 degrees	1	640†	165767	TUBE, suction	1
615	184475	TUBE, suction	1	641†	113344	SWIVEL, union assy	1
616	244524	WIRE, ground assembly w/ clamp	1	642†	158491	FITTING, nipple	1
617	109213	PACKING, o-ring	1	644*	100131	NUT, full hex	4
618	184470	FITTING, outlet	1	645	15J277	CONTROL, de-ice, assembly	1

† Model 287980 only.

★ Model 287981 only.

\* Not shown.

# Cart Parts

## Heavy Duty Cart, Model 287884

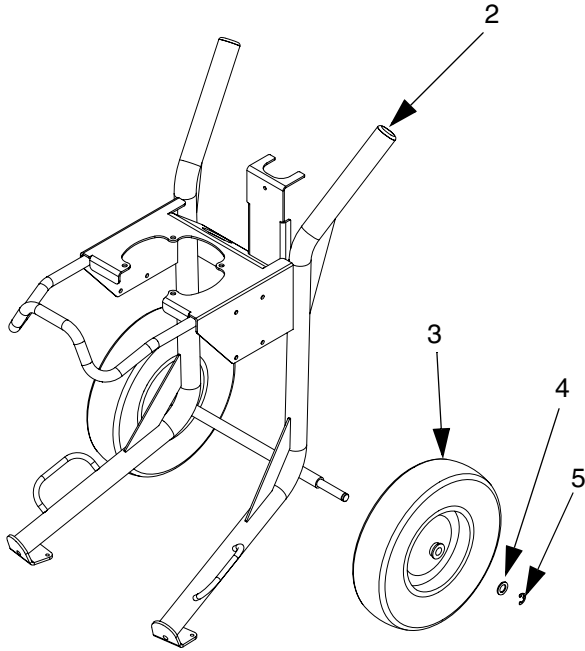

r\_x25dh1\_x45dh1\_311164\_38f

## Light Weight Cart, Model 287919

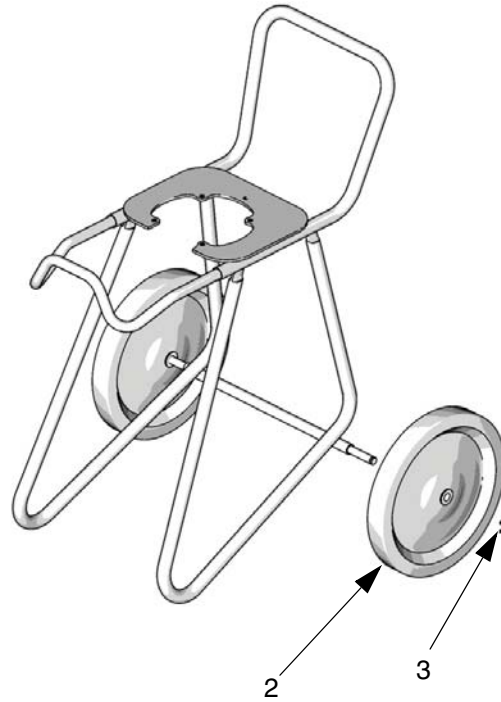

T18409a

Ref.	Part	Description	Qty.
2	113361	CAP, tube, round	2
3	113362	WHEEL, semi-pneumatic	2
4		WASHER	2
5	113436	RING, retaining	2

Ref.	Part	Description	Qty.
2	116406	WHEEL, semi-pneumatic	2
3	113436	RING, retaining	2

# Pump Package Parts

Pump Package	Parts List Page
Pump Packages with L085C# Lowers (80:1 ratio)	pg 44
Pump Packages with L115C# Lowers (35:1, 55:1 ratio)	pg 45
Pump Packages with L145C# and L14AC1 Lowers (31:1, 46:1, 90:1 ratio)	pg 46
Pump Packages with L180C# and L18AC1 Lowers (24:1, 40:1, 70:1 ratio)	pg 47
Pump Packages with L220C# Lowers (21:1, 30:1, 60:1 ratio)	pg 48
Pump Packages with L250C# Lowers (50:1 ratio)	pg 49
Pump Packages with L290C# Lowers (16:1, 25:1, 45:1 ratio)	pg 50

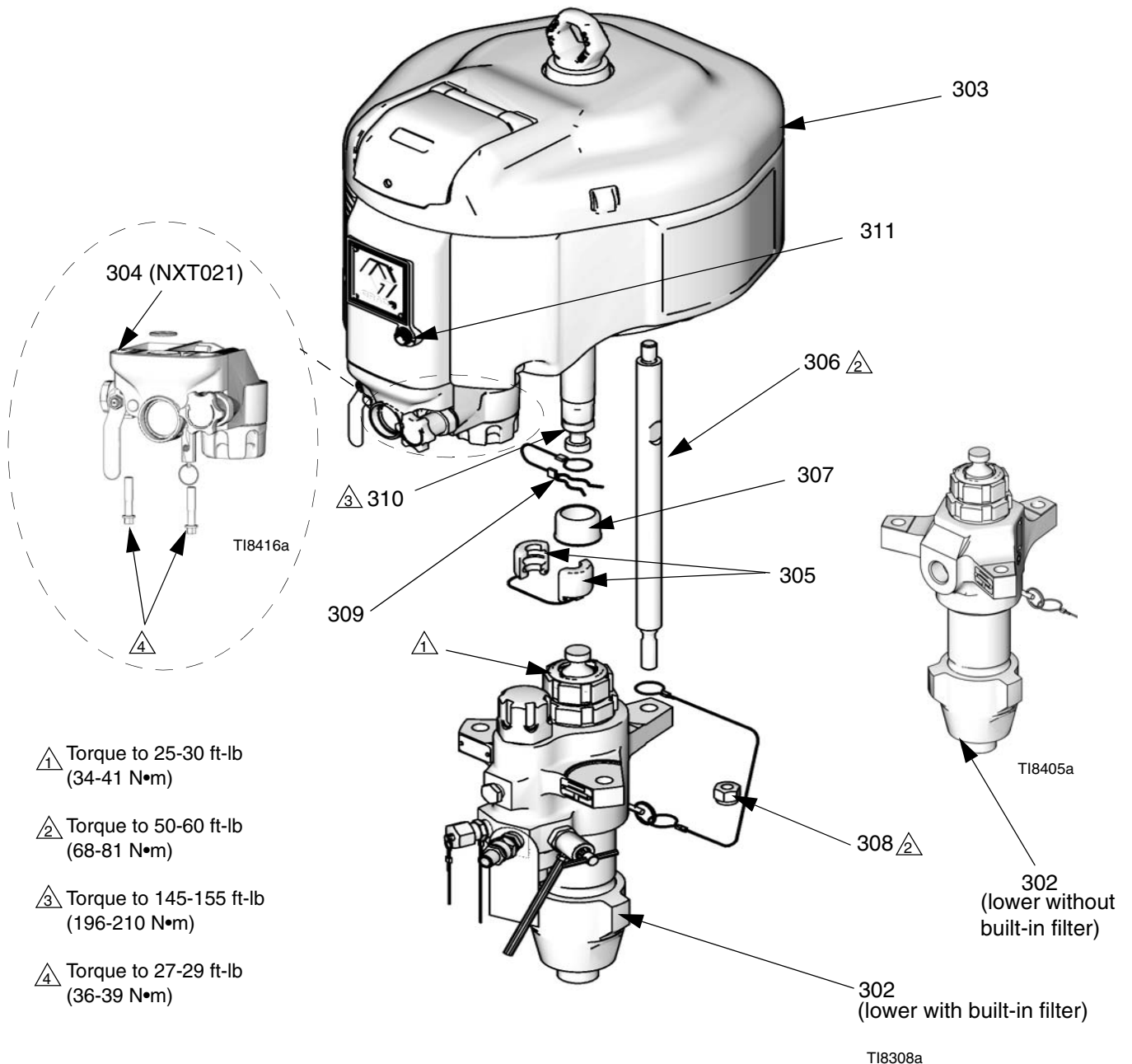

## Pump Packages with L085C# Lowers (80:1 ratio)

Pump Package	Reference Number and Description										
	302		303	304	305	306	307	308	309	310	311
	Lower (see 311762)	Built-in Filter	Motor (see 311238)	Air Control (NXT021) (see 311239)	Coupling, assy.	Rod, tie	Cover, coupler	Nut, lock	Clip, hairpin w/ lanyard	Adapter, rod	De-ice Control Knob
P80DC1	L085C1		N34DN0		247167 (different from all other pack- ages)	257150	197340	101712	244820	15H392	NXT112 (5-pack)
P80DC2	L085C2	✓	N34DN0								
P80DC3	L085C1		N34DN0	✓							
P80DC4	L085C2	✓	N34DN0	✓							
P80EC1	L085C1		N34DT0								
P80EC2	L085C2	✓	N34DT0								
P80EC3	L085C1		N34DT0	✓							
P80EC4	L085C2	✓	N34DT0	✓							
P80LC1	L085C1		N34LN0								
P80LC2	L085C2	✓	N34LN0								
P80LC3	L085C1		N34LN0	✓							
P80LC4	L085C2	✓	N34LN0	✓							
P80MC1	L085C1		N34LT0								
P80MC2	L085C2	✓	N34LT0								
P80MC3	L085C1		N34LT0	✓							
P80MC4	L085C2	✓	N34LT0	✓							
<b>Qty.</b>	1		1	1	1	3	1	3	1	1	1

# Pump Packages with L115C# Lowers (35:1, 55:1 ratio)

Pump Package	Reference Number and Description										
	302		303	304	305	306	307	308	309	310	311
	Lower (see 311762)	Built-in Filter	Motor (see 311238)	Air Control (NXT021) (see 311239)	Coupling, assy.	Rod, tie	Cover, coupler	Nut, lock	Clip, hairpin w/ lanyard	Adapter, rod	De-ice Control Knob
P35DC1	L115C1		N22DN0		247167 (different from all other pack- ages)	257150	197340	101712	244820	15H392	NXT112 (5-pack)
P35DC2	L115C2	✓	N22DN0								
P35DC3	L115C1		N22DN0	✓							
P35DC4	L115C2	✓	N22DN0	✓							
P35EC1	L115C1		N22DT0								
P35EC2	L115C2	✓	N22DT0								
P35EC3	L115C1		N22DT0	✓							
P35EC4	L115C2	✓	N22DT0	✓							
P35LC1	L115C1		N22LN0								
P35LC2	L115C2	✓	N22LN0								
P35LC3	L115C1		N22LN0	✓							
P35LC4	L115C2	✓	N22LN0	✓							
P35MC1	L115C1		N22LT0								
P35MC2	L115C2	✓	N22LT0								
P35MC3	L115C1		N22LT0	✓							
P35MC4	L115C2	✓	N22LT0	✓							
P55DC1	L115C1		N34DN0								
P55DC2	L115C2	✓	N34DN0								
P55DC3	L115C1		N34DN0	✓							
P55DC4	L115C2	✓	N34DN0	✓							
P55EC1	L115C1		N34DT0								
P55EC2	L115C2	✓	N34DT0								
P55EC3	L115C1		N34DT0	✓							
P55EC4	L115C2	✓	N34DT0	✓							
P55LC1	L115C1		N34LN0								
P55LC2	L115C2	✓	N34LN0								
P55LC3	L115C1		N34LN0	✓							
P55LC4	L115C2	✓	N34LN0	✓							
P55MC1	L115C1		N34LT0								
P55MC2	L115C2	✓	N34LT0								
P55MC3	L115C1		N34LT0	✓							
P55MC4	L115C2	✓	N34LT0	✓							
<b>Qty.</b>	1		1	1	1	3	1	3	1	1	1

# Pump Packages with L145C# and L14AC1 Lowers (31:1, 46:1, 90:1 ratio)

Pump Package	Reference Number and Description																	
	302		303	*304	305	306	307	308	309	310	311							
	Lower (see 311762)	Built-in Filter	Motor (see 311238)	Air Control (NXT021) (see 311239)	Coupling, assy.	Rod, tie	Cover, coupler	Nut, lock	Clip, hairpin w/ lanyard	Adapter, rod	De-ice Control Knob							
P31LC1	L14AC1		N22LN0		244819					15H392	NXT112 (5-pack)							
P31MC1	L14AC1		N22LT0															
P31DC1	L14AC1		N22DN0															
P31EC1	L14AC1		N22DT0															
P46DC1	L145C1		N34DN0															
P46DC2	L145C2	✓	N34DN0															
P46DC3	L145C1		N34DN0	✓														
P46DC4	L145C2	✓	N34DN0	✓														
P46EC1	L145C1		N34DT0															
P46EC2	L145C2	✓	N34DT0															
P46EC3	L145C1		N34DT0	✓														
P46EC4	L145C2	✓	N34DT0	✓														
P46LC1	L145C1		N34LN0															
P46LC2	L145C2	✓	N34LN0															
P46LC3	L145C1		N34LN0	✓														
P46LC4	L145C2	✓	N34LN0	✓														
P46MC1	L145C1		N34LT0															
P46MC2	L145C2	✓	N34LT0															
P46MC3	L145C1		N34LT0	✓														
P46MC4	L145C2	✓	N34LT0	✓														
P90DC1	L145C1		N65DN0															
P90DC2	L145C2	✓	N65DN0															
P90DC3	L145C1		N65DN0	✓														
P90DC4	L145C2	✓	N65DN0	✓														
P90EC1	L145C1		N65DT0															
P90EC2	L145C2	✓	N65DT0															
P90EC3	L145C1		N65DT0	✓														
P90EC4	L145C2	✓	N65DT0	✓														
P90LC1	L145C1		N65LN0															
P90LC2	L145C2	✓	N65LN0															
P90LC3	L145C1		N65LN0	✓														
P90LC4	L145C2	✓	N65LN0	✓														
P90MC1	L145C1		N65LT0															
P90MC2	L145C2	✓	N65LT0															
P90MC3	L145C1		N65LT0	✓														
P90MC4	L145C2	✓	N65LT0	✓														
<b>Qty.</b>	1		1	1								1	3	1	3	1	1	1

\* NXT021 Air Control assemblies for P90xxx model pumps are equipped with safety relief valve 116643. Reorder this part number.

# Pump Packages with L180C# and L18AC1 Lowers (24:1, 40:1, 70:1 ratio)

Pump Package	Reference Number and Description										
	302		303	304	305	306	307	308	309	310	311
	Lower (see 311762)	Built-in Filter	Motor (see 311238)	Air Control (NXT021) (see 311239)	Coupling, assy.	Rod, tie	Cover, coupler	Nut, lock	Clip, hairpin w/ lanyard	Adapter, rod	De-ice Control Knob
P24LC1	L18AC1		N22LN0								
P24MC1	L18AC1		N22LT0								
P24DC1	L18AC1		N22DN0								
P24EC1	L18AC1		N22DT0								
P40DC1	L180C1		N34DN0								
P40DC2	L180C2	✓	N34DN0								
P40DC3	L180C1		N34DN0	✓							
P40DC4	L180C2	✓	N34DN0	✓							
P40EC1	L180C1		N34DT0								
P40EC2	L180C2	✓	N34DT0								
P40EC3	L180C1		N34DT0	✓							
P40EC4	L180C2	✓	N34DT0	✓							
P40LC1	L180C1		N34LN0								
P40LC2	L180C2	✓	N34LN0								
P40LC3	L180C1		N34LN0	✓							
P40LC4	L180C2	✓	N34LN0	✓							
P40MC1	L180C1		N34LT0								
P40MC2	L180C2	✓	N34LT0								
P40MC3	L180C1		N34LT0	✓	244819	257150	197340	101712	244820	15H392	NXT112 (5-pack)
P40MC4	L180C2	✓	N34LT0	✓							
P70DC1	L180C1		N65DN0								
P70DC2	L180C2	✓	N65DN0								
P70DC3	L180C1		N65DN0	✓							
P70DC4	L180C2	✓	N65DN0	✓							
P70EC1	L180C1		N65DT0								
P70EC2	L180C2	✓	N65DT0								
P70EC3	L180C1		N65DT0	✓							
P70EC4	L180C2	✓	N65DT0	✓							
P70LC1	L180C1		N65LN0								
P70LC2	L180C2	✓	N65LN0								
P70LC3	L180C1		N65LN0	✓							
P70LC4	L180C2	✓	N65LN0	✓							
P70MC1	L180C1		N65LT0								
P70MC2	L180C2	✓	N65LT0								
P70MC3	L180C1		N65LT0	✓							
P70MC4	L180C2	✓	N65LT0	✓							
Qty.	1		1	1	1	3	1	3	1	1	1

# Pump Packages with L220C# Lowers (21:1, 30:1, 60:1 ratio)

Pump Package	Reference Number and Description										
	302		303	304	305	306	307	308	309	310	311
	Lower (see 311762)	Built-in Filter	Motor (see 311238)	Air Control (NXT021) (see 311239)	Coupling, assy.	Rod, tie	Cover, coupler	Nut, lock	Clip, hairpin w/ lanyard	Adapter, rod	De-ice Control Knob
P21DC1	L22AC1		N22DN0								
P21EC1	L22AC1		N22DT0								
P21LC1	L22AC1		N22LN0								
P21MC1	L22AC1		N22LT0								
P30DC1	L220C1		N34DN0								
P30DC2	L220C2	✓	N34DN0								
P30DC3	L220C1		N34DN0	✓							
P30DC4	L220C2	✓	N34DN0	✓							
P30EC1	L220C1		N34DT0								
P30EC2	L220C2	✓	N34DT0								
P30EC3	L220C1		N34DT0	✓							
P30EC4	L220C2	✓	N34DT0	✓							
P30LC1	L220C1		N34LN0								
P30LC2	L220C2	✓	N34LN0								
P30LC3	L220C1		N34LN0	✓							
P30LC4	L220C2	✓	N34LN0	✓							
P30MC1	L220C1		N34LT0								
P30MC2	L220C2	✓	N34LT0								
P30MC3	L220C1		N34LT0	✓	244819	257150	197340	101712	244820	15H392	NXT112 (5-pack)
P30MC4	L220C2	✓	N34LT0	✓							
P60DC1	L220C1		N65DN0								
P60DC2	L220C2	✓	N65DN0								
P60DC3	L220C1		N65DN0	✓							
P60DC4	L220C2	✓	N65DN0	✓							
P60EC1	L220C1		N65DT0								
P60EC2	L220C2	✓	N65DT0								
P60EC3	L220C1		N65DT0	✓							
P60EC4	L220C2	✓	N65DT0	✓							
P60LC1	L220C1		N65LN0								
P60LC2	L220C2	✓	N65LN0								
P60LC3	L220C1		N65LN0	✓							
P60LC4	L220C2	✓	N65LN0	✓							
P60MC1	L220C1		N65LT0								
P60MC2	L220C2	✓	N65LT0								
P60MC3	L220C1		N65LT0	✓							
P60MC4	L220C2	✓	N65LT0	✓							
<b>Qty.</b>	1		1	1	1	3	1	3	1	1	1



## Pump Packages with L250C# Lowers (50:1 ratio)

Pump Package	Reference Number and Description										
	302		303	304	305	306	307	308	309	310	311
	Lower (see 311762)	Built-in Filter	Motor (see 311238)	Air Control (NXT021) (see 311239)	Coupling, assy.	Rod, tie	Cover, coupler	Nut, lock	Clip, hairpin w/ lanyard	Adapter, rod	De-ice Control Knob
P50DC1	L250C1		N65DN0		244819	257150	197340	101712	244820	15H392	NXT112 (5-pack)
P50DC2	L250C2	✓	N65DN0								
P50DC3	L250C1		N65DN0	✓							
P50DC4	L250C2	✓	N65DN0	✓							
P50EC1	L250C1		N65DT0								
P50EC2	L250C2	✓	N65DT0								
P50EC3	L250C1		N65DT0	✓							
P50EC4	L250C2	✓	N65DT0	✓							
P50LC1	L250C1		N65LN0								
P50LC2	L250C2	✓	N65LN0								
P50LC3	L250C1		N65LN0	✓							
P50LC4	L250C2	✓	N65LN0	✓							
P50MC1	L250C1		N65LT0								
P50MC2	L250C2	✓	N65LT0								
P50MC3	L250C1		N65LT0	✓							
P50MC4	L250C2	✓	N65LT0	✓							
<b>Qty.</b>	1		1	1	1	3	1	3	1	1	1

## Pump Packages with L290C# Lowers (16:1, 25:1, 45:1 ratio)

Pump Package	Reference Number and Description										
	302		303	304	305	306	307	308	309	310	311
	Lower (see 311762)	Built-in Filter	Motor (see 311238)	Air Control (NXT021) (see 311239)	Coupling, assy.	Rod, tie	Cover, coupler	Nut, lock	Clip, hairpin w/ lanyard	Adapter, rod	De-ice Control Knob
P16DC1	L29AC1		N22DN0								
P16EC1	L29AC1		N22DT0								
P16LC1	L29AC1		N22LN0								
P16MC1	L29AC1		N22LT0								
P25DC1	L290C1		N34DN0								
P25DC2	L290C2	✓	N34DN0								
P25DC3	L290C1		N34DN0	✓							
P25DC4	L290C2	✓	N34DN0	✓							
P25EC1	L290C1		N34DT0								
P25EC2	L290C2	✓	N34DT0								
P25EC3	L290C1		N34DT0	✓							
P25EC4	L290C2	✓	N34DT0	✓							
P25LC1	L290C1		N34LN0								
P25LC2	L290C2	✓	N34LN0								
P25LC3	L290C1		N34LN0	✓							
P25LC4	L290C2	✓	N34LN0	✓							
P25MC1	L290C1		N34LT0								
P25MC2	L290C2	✓	N34LT0								
P25MC3	L290C1		N34LT0	✓	244819	257150	197340	101712	244820	15H392	NXT112 (5-pack)
P25MC4	L290C2	✓	N34LT0	✓							
P45DC1	L290C1		N65DN0								
P45DC2	L290C2	✓	N65DN0								
P45DC3	L290C1		N65DN0	✓							
P45DC4	L290C2	✓	N65DN0	✓							
P45EC1	L290C1		N65DT0								
P45EC2	L290C2	✓	N65DT0								
P45EC3	L290C1		N65DT0	✓							
P45EC4	L290C2	✓	N65DT0	✓							
P45LC1	L290C1		N65LN0								
P45LC2	L290C2	✓	N65LN0								
P45LC3	L290C1		N65LN0	✓							
P45LC4	L290C2	✓	N65LN0	✓							
P45MC1	L290C1		N65LT0								
P45MC2	L290C2	✓	N65LT0								
P45MC3	L290C1		N65LT0	✓							
P45MC4	L290C2	✓	N65LT0	✓							
<b>Qty.</b>	1		1	1	1	3	1	3	1	1	1

# Dimensions

## Sprayer (Cart Mounted) Packages

Model X60DH3 Shown

Top View - Heavy Duty Cart Shown

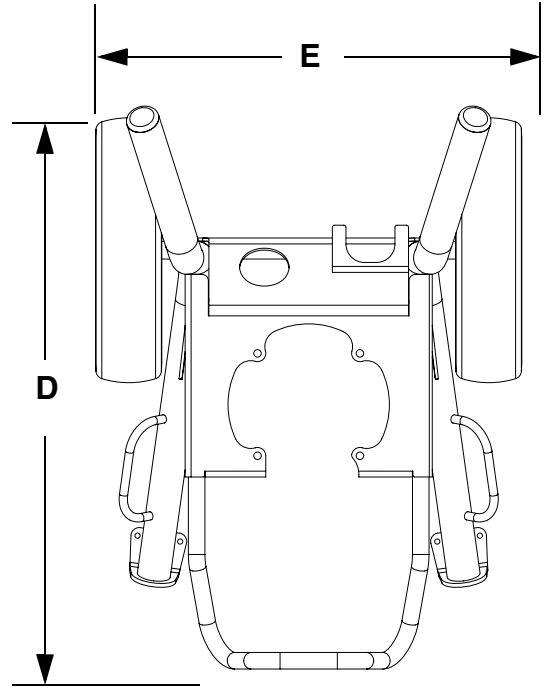
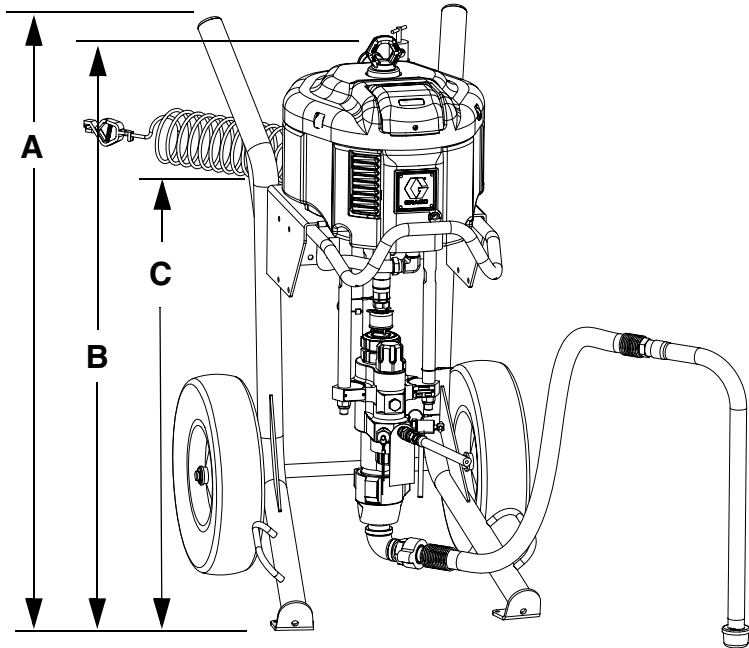

r\_x25dh1\_x45dh1\_311164\_47f2

r\_x25dh1\_x45dh1\_311164\_47f

**KEY:**

HD = Heavy Duty Cart  
LW = Light Weight Cart

## All Xtreme Sprayer (Cart Mounted) Packages

Mount	A	B	C	D	E
HD	43.69 in. (1109.73 mm)	46.0 in. (1168.4 mm)	32.0 in. (812.8 mm)	35.0 in. (889 mm)	25.72 in. (653.3 mm)
LW	44.86 in. (1139.44 mm)	45.5 in. (1115.7 mm)	31.3 in. (795 mm)	34.0 in. (863.6 mm)	27.09 in. (688.1 mm)
HD with Hopper	43.69 in. (1109.73 mm)	46.0 in. (1168.4 mm)	32.0 in. (812.8 mm)	45.0 in. (1143 mm)	25.72 in. (653.3 mm)
LW with Hopper	44.86 in. (1139.44 mm)	45.5 in. (1115.7 mm)	31.3 in. (795 mm)	44.0 in. (1117.6 mm)	27.09 in. (688.1 mm)

### Wall Mount Packages and Pump Packages

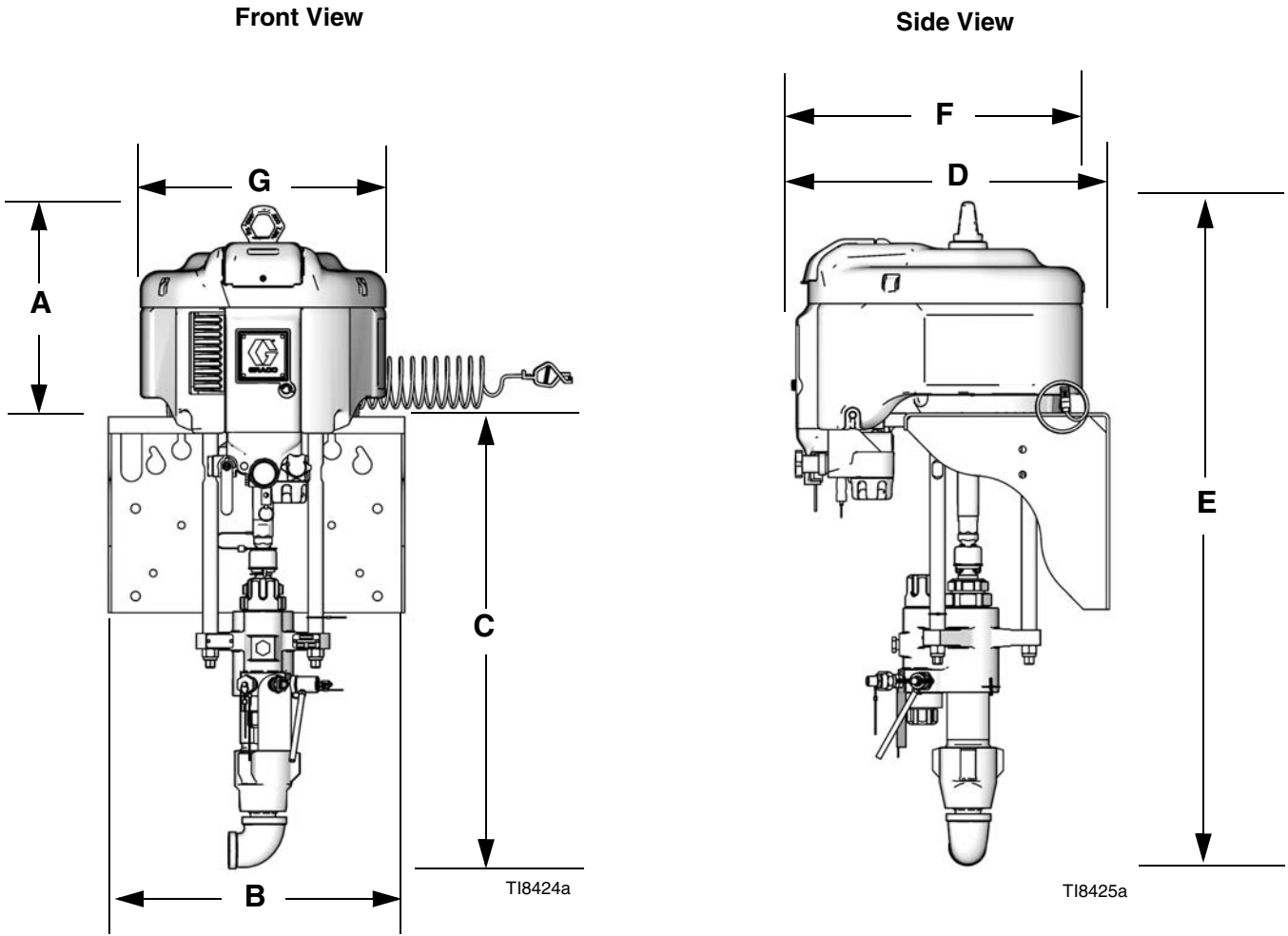

#### Wall Mount Dimensions

 **NOTE: Dimensions based on largest air motor and lower combination.**

A	B	C	D	E	F	G
14.0 in. (355.6 mm)	17.75 in. (450.6 mm)	29.0 in. (736.6 mm)	19.25 in. (489 mm)	43.0 in. (1092.2 mm)	18.9 in. (480 mm)	16.2 in. (410 mm)

## Weights



**NOTE: Weights are approximate and do not include hoses or guns.**

### Sprayer (Cart Mounted) Packages

Ratio	Heavy Duty Cart lbs (kg)	Light Weight Cart lbs (kg)
25:1	228.4 (103.6)	196.1 (89.0)
30:1	227.4 (103.1)	195.1 (88.5)
35:1	209.9 (95.2)	177.6 (80.6)
40:1	223.4 (101.3)	191.1 (86.7)
45:1	247.4 (112.2)	215.1 (97.6)
46:1	223.4 (101.3)	191.1 (86.7)
50:1	246.4 (111.8)	214.1 (97.1)
55:1	211.4 (95.9)	179.1 (81.2)
60:1	246.4 (111.8)	214.1 (97.1)
70:1	242.4 (109.9)	210.1 (95.3)
80:1	211.4 (95.9)	179.1 (81.2)
90:1	242.4 (109.9)	210.1 (95.3)

### Wall Mount Packages

Ratio	lbs (kg)
25:1	159.0 (72.1)
30:1	158.0 (71.7)
35:1	140.5 (63.7)
40:1	154.0 (69.9)
45:1	178.0 (80.8)
46:1	154.0 (69.9)
50:1	177.0 (80.3)
55:1	142.0 (64.4)
60:1	177.0 (80.3)
70:1	173.0 (78.5)
80:1	142.0 (64.4)
90:1	173.0 (78.5)

### Pump Assembly Packages

Ratio	No Filter, No Air Controls* lbs (kg)
16:1	99.4 (45.1)
21:1	98.4 (44.6)
24:1	94.4 (42.8)
25:1	103.4 (46.9)
30:1	102.4 (46.4)
31:1	94.4 (42.8)
35:1	84.4 (38.3)
40:1	98.4 (44.6)
45:1	122.4 (55.5)
46:1	98.4 (44.6)
50:1	121.4 (55.1)
55:1	88.4 (40.1)
60:1	121.4 (55.1)
70:1	117.4 (53.3)
80:1	88.4 (40.1)
90:1	117.4 (53.3)

\* Add 10 lbs (4.54 kg) for built-in filter. Add 5 lbs (2.27 kg) for air controls.



# Accessories

## Adapter Plate 247312

Adapter plate is required to mount pump assemblies with an NXT2200 air motor to cart or wall mount bracket.

## NXT021 Air Control Module

Includes Safety Relief Valve 113498 (pressure relief at 110 psi (7.7 MPa, 77 bar)). If you have a 90:1 pump package, also order Safety Relief Valve 116643 (pressure relief at 90 psi (6.3 MPa, 63 bar)).

## DataTrak Upgrade Kits

NXT206 kit for NXT2200 air motors

NXT306 kit for NXT3400 air motors

NXT606 kit for NXT6500 air motors

## Hopper Kit 288347

Hopper kit attaches to cart mounted sprayers. See **Hopper Assembly**, page 26, for illustration of kit and kit parts.

# Technical Data

Maximum air inlet pressure	Models with 16:1 - 80:1 pressure ratios: 100 psi (0.7 MPa, 7 bar). Models with a 90:1 pressure ratio: 80 psi (0.55 MPa, 5.5 bar).
Air motor piston diameter	<i>NXT Model 6500</i> : 10.375 in. (264 mm) <i>NXT Model 3400</i> : 7.5 in. (191 mm) <i>NXT Model 2200</i> : 6.0 in. (152 mm)
Stroke length	4.75 in. (120 mm)
Air Inlet Size	3/4 npt(f)
Fluid Inlet Size	1-1/4 npt(m)
Fluid Outlet Size	<i>All pumps with built-in filters (2 outlet ports)</i> : 1/2 npt(m) <i>Pumps without built-in filters (1 outlet port)</i> : 85cc and 115cc pumps: 1/2 npt(f) 145cc and 180cc pumps: 3/4 npt(f) 220cc, 250cc, and 290cc pumps: 1 npt(f)
Maximum pump speed (Do not exceed maximum recommended speed of fluid pump, to prevent premature pump wear)	60 cycles per minute

 **NOTE: See NXT Motor manual (311238) for sound data.**

## Maximum Working Pressure and Flow Rate at Full Air Pressure (100 psi)

Ratio	Maximum Working Pressure psi (MPa, bar)	NXT Air Motor	Lower (cc per cycle)	Flow Rate gpm (lpm)	
				30 cpm	60 cpm
16:1	1520 (10.5, 105)	2200	290	2.3 (8.7)	4.6 (17.0)
21:1	2025 (14.0, 140)	2200	220	1.74 (6.6)	3.4 (12.9)
24:1	2400 (16.5, 165)	2200	180	1.43 (5.4)	2.9 (11.0)
25:1	2375 (16.4, 164)	3400	290	2.3 (8.7)	4.6 (17.0)
30:1	3150 (21.7, 217)	3400	220	1.74 (6.6)	3.4 (12.9)
31:1	3000 (20.7, 207)	2200	145	1.15 (4.4)	2.3 (8.7)
35:1	3800 (26.2, 262)	2200	115	0.95 (3.6)	2.0 (7.6)
40:1	3800 (26.2, 262)	3400	180	1.43 (5.4)	2.9 (11.0)
45:1	4500 (31.0, 310)	6500	290	2.3 (8.7)	4.6 (17.0)
46:1	4750 (32.7, 327)	3400	145	1.15 (4.4)	2.3 (8.7)
50:1	5000 (34.5, 345)	6500	250	2.0 (7.6)	4.0 (15.2)
55:1	5600 (38.6, 386)	3400	115	0.95 (3.6)	2.0 (7.6)
60:1	6000 (41.7, 417)	6500	220	1.74 (6.6)	3.4 (12.9)
70:1	7250 (50.0, 500)	6500	180	1.43 (5.4)	2.9 (11.0)
80:1	7250 (50.0, 500)	3400	85	0.8 (3.0)	1.5 (5.7)
90:1	7250 (50.0, 500)	6500	145	1.15 (4.4)*	2.3 (8.7)*

\* At 80 psi (0.55 MPa, 5.5 bar)



# Pump Package Performance Charts

## Calculate Fluid Outlet Pressure

To calculate fluid outlet pressure (psi/MPa/bar) at a specific fluid flow (gpm/lpm) and operating air pressure (psi/MPa/bar), use the following instructions and pump data charts.

1. Locate desired flow along bottom of chart.
2. Follow vertical line up to intersection with selected fluid outlet pressure curve. Follow left to scale to read fluid outlet pressure.

Key: Air Pressure

- A 100 psi (0.7 MPa, 7 bar)
- B 70 psi (0.5 MPa, 7.8 bar)
- C 40 psi (0.3 MPa, 2.8 bar)

Dashed lines indicate low noise motors.

## Calculate Pump Air Flow/Consumption

To calculate pump air flow/consumption (scfm or m<sup>3</sup>/min) at a specific fluid flow (gpm/lpm) and air pressure (psi/MPa/bar), use the following instructions and pump data charts.

1. Locate desired flow along bottom of chart.
2. Follow vertical line up to intersection with selected air flow/consumption curve. Follow right to scale to read air flow/consumption.

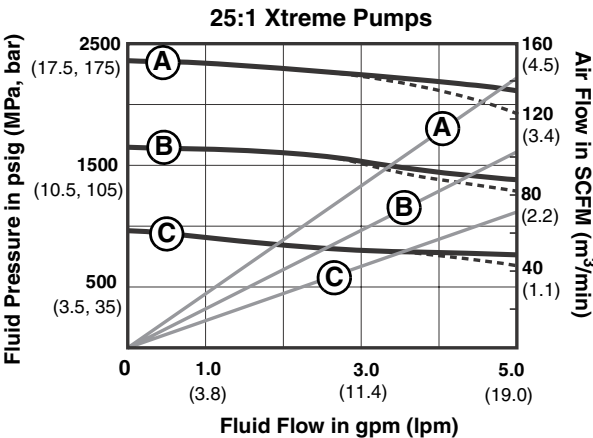
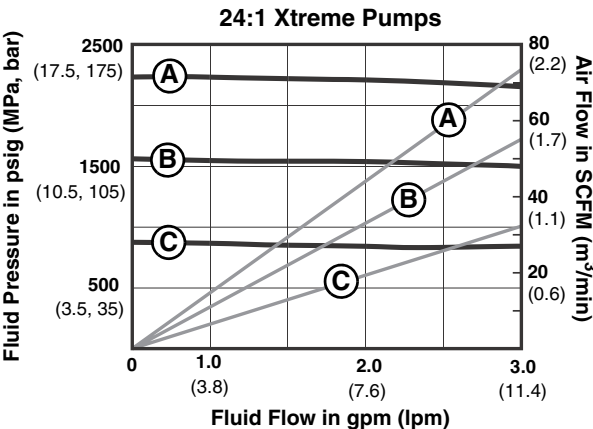
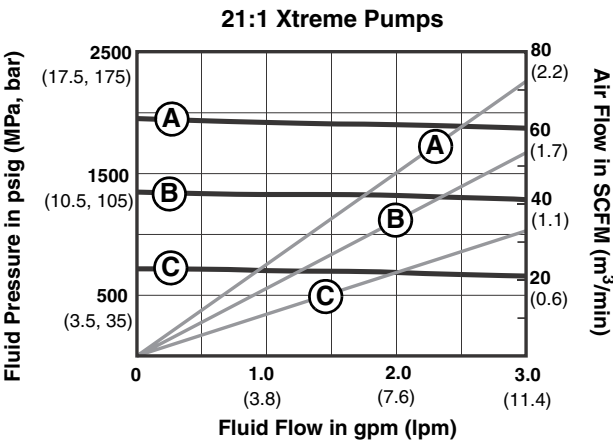
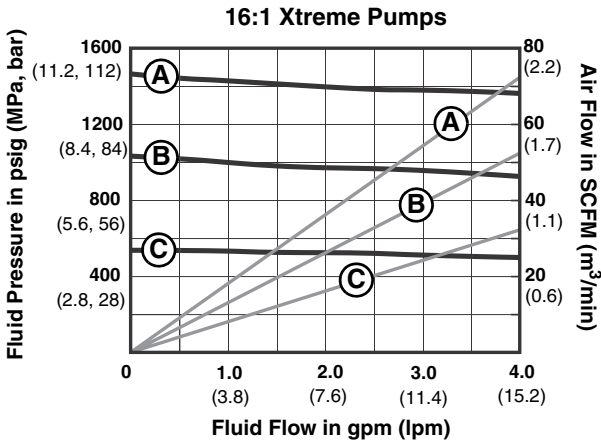

Pump Package Performance Charts (cont.)

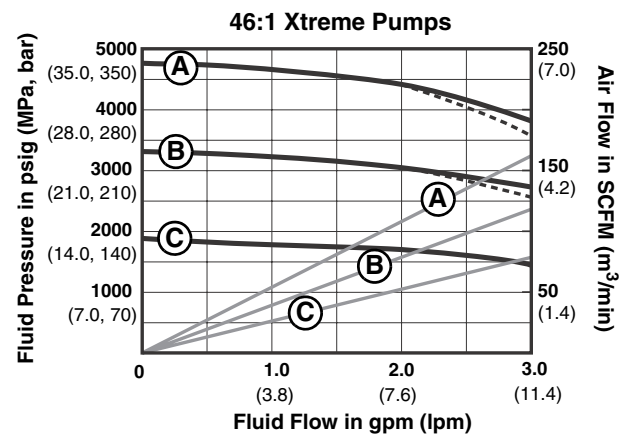
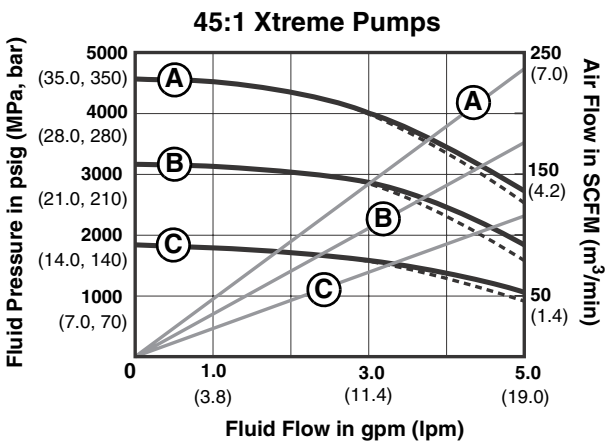
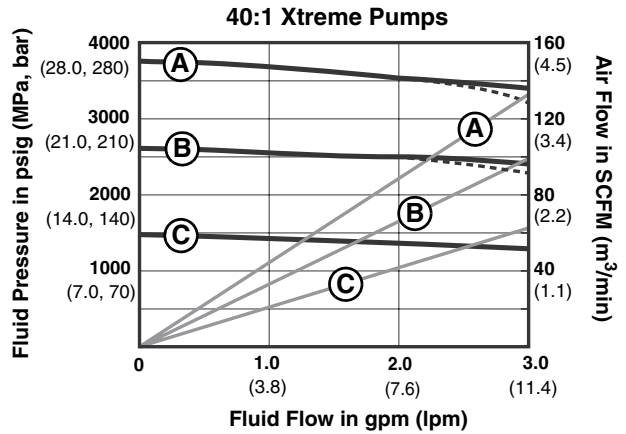
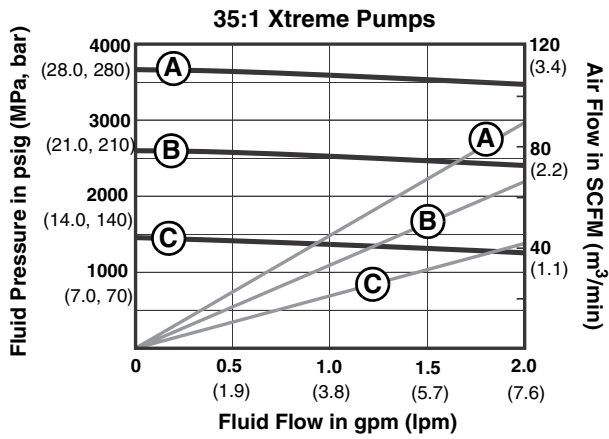
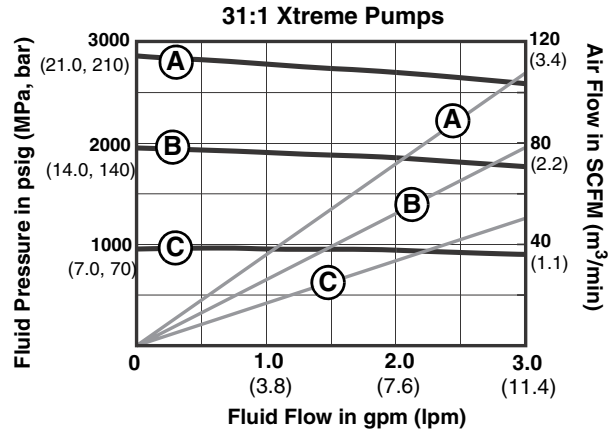
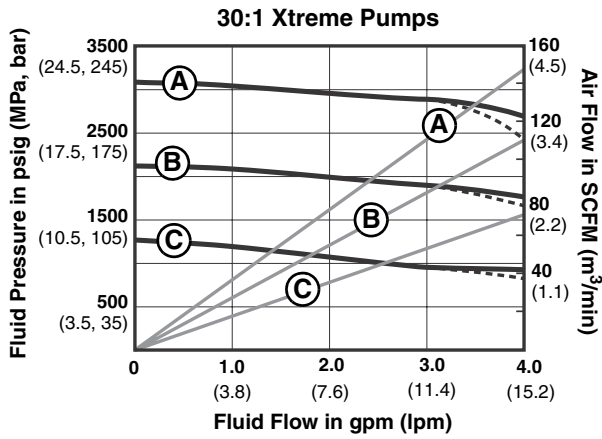

Pump Package Performance Charts (cont.)

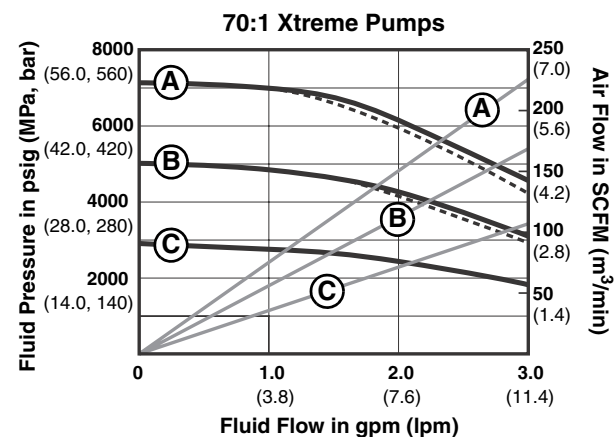
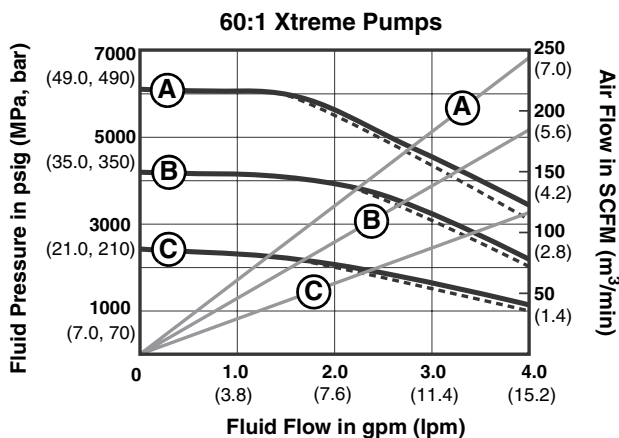
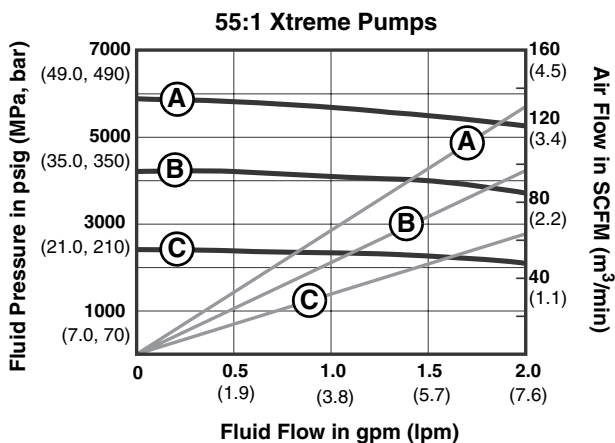
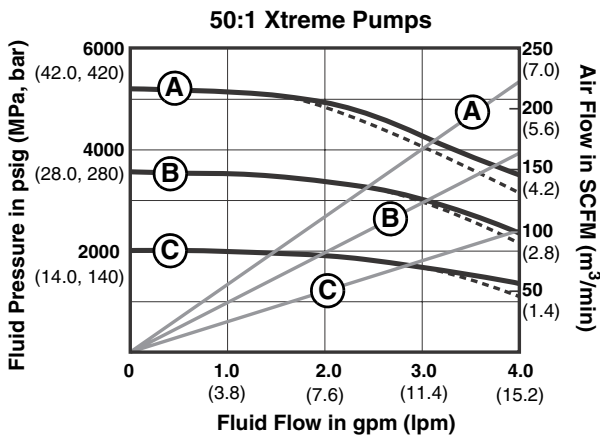

**Key: 90:1 Pumps Air Pressure**  
 B 80 psi (0.56 MPa, 5.6 bar)  
 C 40 psi (0.28 MPa, 2.8 bar)

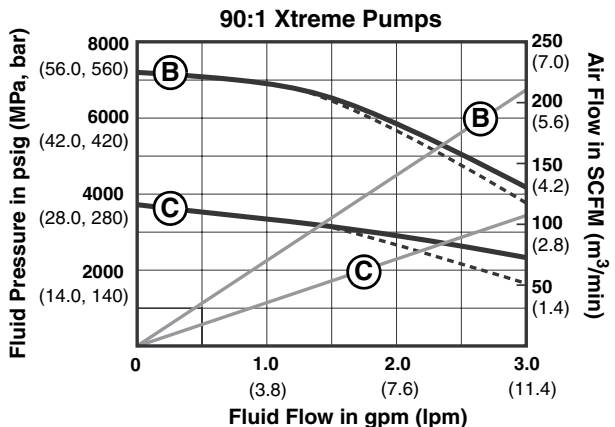
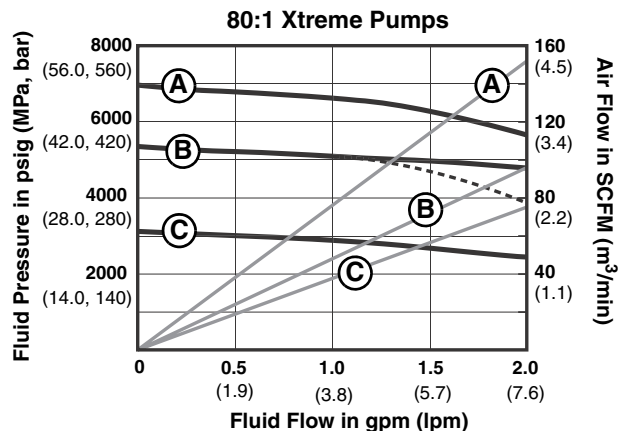

# Graco Standard Warranty

Graco warrants all equipment referenced in this document which is manufactured by Graco and bearing its name to be free from defects in material and workmanship on the date of sale to the original purchaser for use. With the exception of any special, extended, or limited warranty published by Graco, Graco will, for a period of twelve months from the date of sale, repair or replace any part of the equipment determined by Graco to be defective. This warranty applies only when the equipment is installed, operated and maintained in accordance with Graco's

written recommendations.

This warranty does not cover, and Graco shall not be liable for general wear and tear, or any malfunction, damage or wear caused by faulty installation, misapplication, abrasion, corrosion, inadequate or improper maintenance, negligence, accident, tampering, or substitution of non-Graco component parts. Nor shall Graco be liable for malfunction, damage or wear caused by the incompatibility of Graco equipment with structures, accessories, equipment or materials not supplied by Graco, or the improper design, manufacture, installation, operation or maintenance of structures, accessories, equipment or materials not supplied by Graco.

This warranty is conditioned upon the prepaid return of the equipment claimed to be defective to an authorized Graco distributor for verification of the claimed defect. If the claimed defect is verified, Graco will repair or replace free of charge any defective parts. The equipment will be returned to the original purchaser transportation prepaid. If inspection of the equipment does not disclose any defect in material or workmanship, repairs will be made at a reasonable charge, which charges may include the costs of parts, labor, and transportation.

**THIS WARRANTY IS EXCLUSIVE, AND IS IN LIEU OF ANY OTHER WARRANTIES, EXPRESS OR IMPLIED, INCLUDING BUT NOT LIMITED TO WARRANTY OF MERCHANTABILITY OR WARRANTY OF FITNESS FOR A PARTICULAR PURPOSE.**

Graco's sole obligation and buyer's sole remedy for any breach of warranty shall be as set forth above. The buyer agrees that no other remedy (including, but not limited to, incidental or consequential damages for lost profits, lost sales, injury to person or property, or any other incidental or consequential loss) shall be available. Any action for breach of warranty must be brought within two (2) years of the date of sale.

**GRACO MAKES NO WARRANTY, AND DISCLAIMS ALL IMPLIED WARRANTIES OF MERCHANTABILITY AND FITNESS FOR A PARTICULAR PURPOSE, IN CONNECTION WITH ACCESSORIES, EQUIPMENT, MATERIALS OR COMPONENTS SOLD BUT NOT MANUFACTURED BY GRACO.** These items sold, but not manufactured by Graco (such as electric motors, switches, hose, etc.), are subject to the warranty, if any, of their manufacturer. Graco will provide purchaser with reasonable assistance in making any claim for breach of these warranties.

In no event will Graco be liable for indirect, incidental, special or consequential damages resulting from Graco supplying equipment hereunder, or the furnishing, performance, or use of any products or other goods sold hereto, whether due to a breach of contract, breach of warranty, the negligence of Graco, or otherwise.

## **FOR GRACO CANADA CUSTOMERS**

The Parties acknowledge that they have required that the present document, as well as all documents, notices and legal proceedings entered into, given or instituted pursuant hereto or relating directly or indirectly hereto, be drawn up in English. Les parties reconnaissent avoir convenu que la rédaction du présente document sera en Anglais, ainsi que tous documents, avis et procédures judiciaires exécutés, donnés ou intentés, à la suite de ou en rapport, directement ou indirectement, avec les procédures concernées.

# Graco Information

For the latest information about Graco products, visit [www.graco.com](http://www.graco.com).

**TO PLACE AN ORDER**, contact your Graco distributor or call to identify the nearest distributor.

**Phone:** 612-623-6921 **or Toll Free:** 1-800-328-0211 **Fax:** 612-378-3505

*All written and visual data contained in this document reflects the latest product information available at the time of publication. Graco reserves the right to make changes at any time without notice.*

*For patent information, see [www.graco.com/patents](http://www.graco.com/patents).*

Original instructions. This manual contains English. MM 311164

**Graco Headquarters:** Minneapolis  
**International Offices:** Belgium, China, Japan, Korea

**GRACO INC. AND SUBSIDIARIES • P.O. BOX 1441 • MINNEAPOLIS MN 55440-1441 • USA**

Copyright 2006, Graco Inc. All Graco manufacturing locations are registered to ISO 9001.

[www.graco.com](http://www.graco.com)

Revised August 2012