

HFR™ Discrete Gateway Module Kits

3A1149F
EN

For external control of the HFR system. For professional use only. Not approved for use in European explosive atmosphere locations.

Single Discrete Gateway Module Kit, 24F843
Dual Discrete Gateway Modules Kit, 24F844
Discrete Gateway Module, 24G830



Important Safety Instructions

Read all warnings and instructions in the HFR operation manual 313997. Save all instructions.

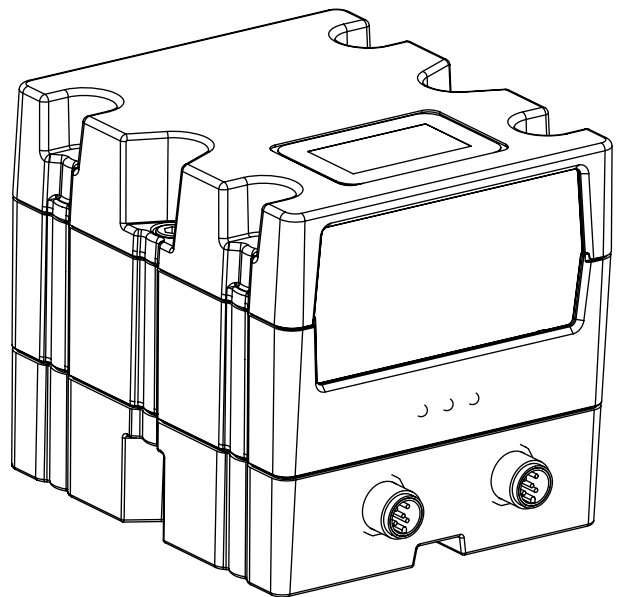

r_24B681_2B9904_1b



Contents

Related Manuals	2	Timing Diagrams	25
Overview	3	Heartbeat	25
DGM Presence	3	Activate System Stop Button	25
Automation Presence	3	System Requests	26
Typical Installation	4	Select an Operating Mode or Shot Number ...	26
Component Identification	5	Change Setpoint	27
Module Requirements	6	Toggle On/Off	27
I/O Setup	6	Operator Mode Dispense	28
DGM Digital Input Overview	7	Maintenance	29
DGM Digital Outputs Overview	8	Install Upgrade Token	29
DGM Analog Inputs Overview	9	Check Cable Connections	29
DGM Analog Outputs Overview	9	Troubleshooting	30
Primary DGM Pin Assignments	10	Diagnostic Information	30
Secondary DGM Pin Assignments	12	Fault Code Bit Pattern Table	30
Setup	14	Parts	33
Operation	16	Accessories	34
Primary DGM Digital Inputs	16	Technical Data	34
Primary DGM Digital Outputs	18	Graco Standard Warranty	36
Primary DGM Analog Inputs	19	Graco Information	36
Primary DGM Analog Outputs	20		
Secondary DGM I/O Overview	21		
Secondary DGM Digital Inputs	22		
Secondary DGM Digital Outputs	22		
Secondary DGM Analog Inputs	23		
Secondary DGM Analog Outputs	24		

Related Manuals

The following manuals are available at www.graco.com.
Manuals are in English.

Part	Description
313997	HFR Operation
313998	HFR Repair-Parts

Overview

This Discrete Gateway Module (DGM) allows the user to control an HFR through an external control device such as a PLC. The DGM will operate in conjunction with the existing Advanced Display Module (ADM) such that both devices can be used to control the machine. Each HFR can be controlled using up to two DGM's which will be referred to as the primary and secondary DGM's.

The primary DGM allows the user to monitor and control general machine functions. This includes the following capabilities:

- Dispensing
- Operating mode selection
- Shot selection
- Fault code monitoring
- Fault acknowledgment
- Pump parking
- Monitoring working pressures of each pump
- Monitoring the combined flow or B (Blue) pump pressure while dispensing
- System Stop button
- Changing the combined flow or B (Blue) pump pressure in operator mode

The secondary DGM is used for monitoring and controlling the temperature conditioning components. These features include:

- Monitoring which conditioning zones are enabled
- Monitoring temperatures of enabled zones
- Turning on or off the enabled zones
- Changing temperature setpoints of enabled zones

NOTE: Changing temperature setpoints is only available on machines with 2nd generation ADMs. 2nd generation ADMs are distinguishable by having only 2 cable connections on the bottom of the ADM. 1st generation ADMs have 4 cable connections.

DGM Presence

The DGM will broadcast a heartbeat to the HFR every 5 seconds. In the event that the DGM fails to broadcast a heartbeat after 10 seconds, the system will go into disabled mode.

The system can be taken out of disabled mode after acknowledging the alarm on the ADM.

Automation Presence

The primary DGM includes a heartbeat monitor. This serves as a verification that the PLC and DGM are communicating. In the event that the PLC becomes unresponsive, the DGM will terminate any active dispenses and set the machine to disabled mode.

Typical Installation

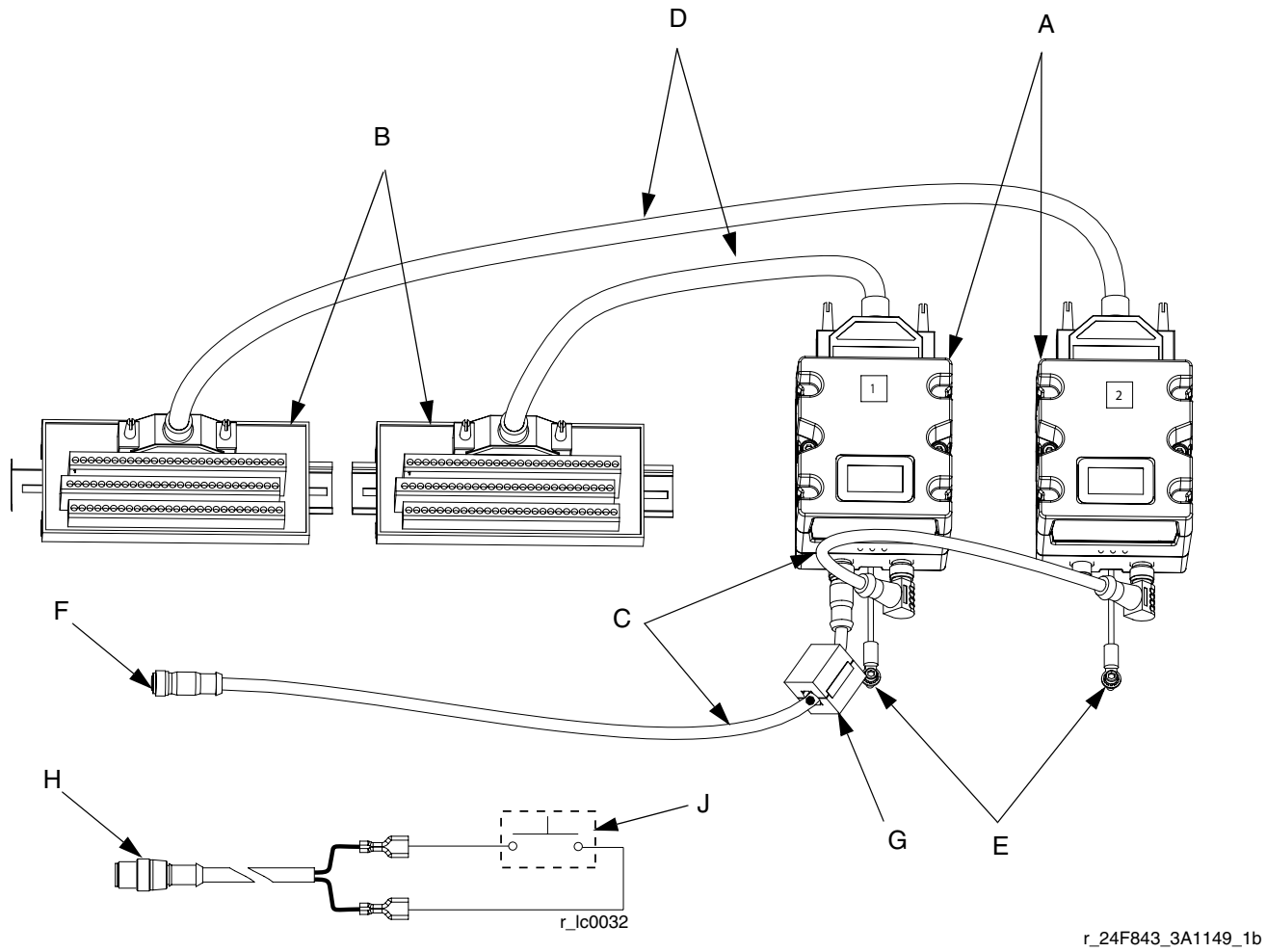

FIG. 1

Key:

- A Discrete Gateway Module (DGM)
- B Breakout Board
- C CAN Cables
- D 78 Pin D-Sub Cables (Male to Female)
- E Ground screw
- F Connects to HFR
- G Ferrite Suppressor
- H CAN Cable to Motor Control Module (MCM) 2B Port*
- J Start Dispense Signal (Customer Supplied)**

* Cable provided with dispense gun or can be purchased separately. Refer to **Accessories** for item information.

** Connect cable to MCM, port 2B, and a customer provided signal device. The signal device must have isolated, dry contacts.

Component Identification

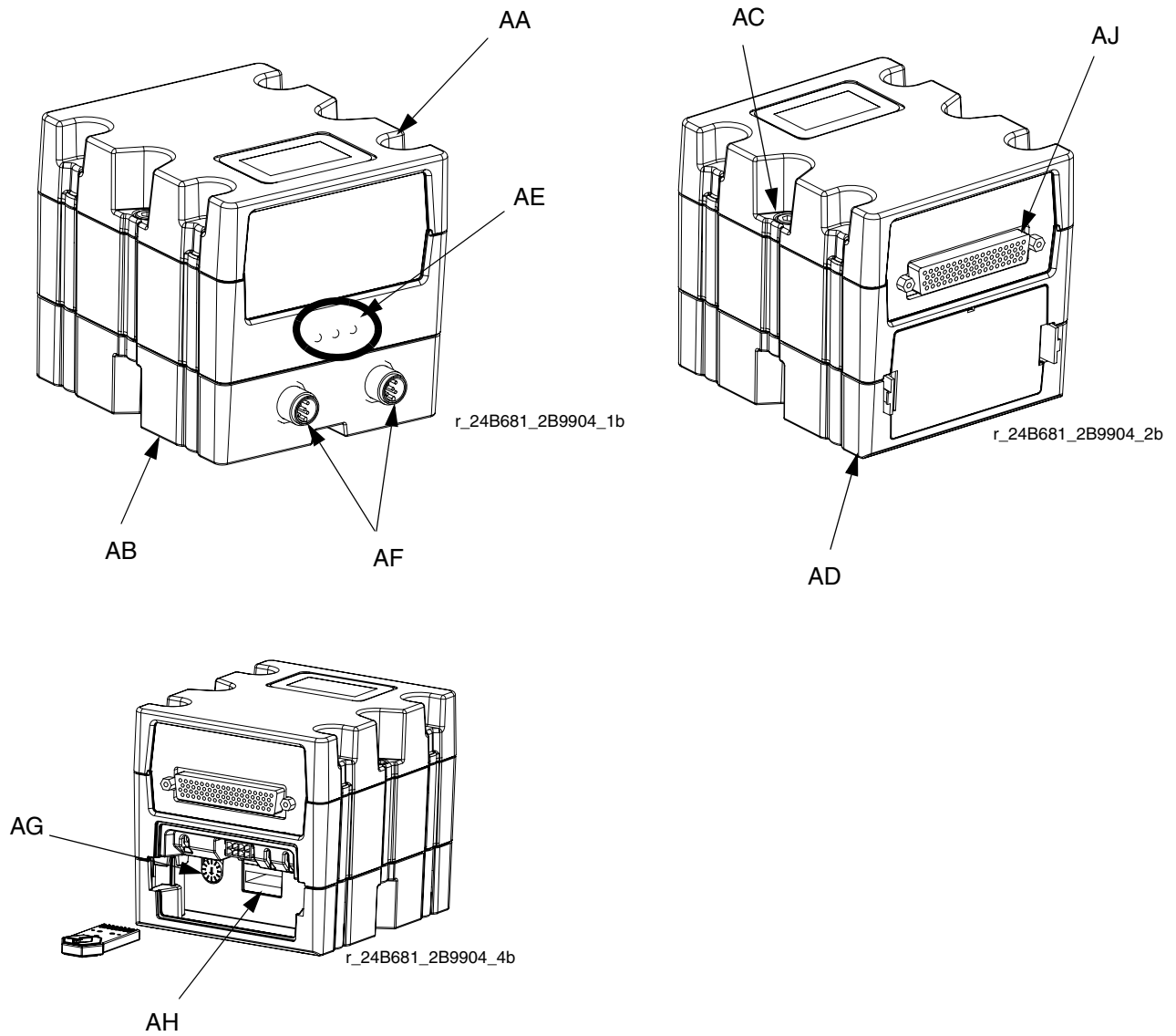

FIG. 2:

Key:

- AA Discrete Gateway Module (DGM)
- AB Base
- AC Module Connection Screws
- AD Access Cover
- AE Module Status LEDs
- AF CAN Connectors
- AG Rotary Switch
- AH Token Slot
- AJ D-Sub Connection

Module Requirements

Each DGM requires a 9-30 VDC NEC Class 2 power supply. This is supplied to the DGM through pins 27, 51, 68, 69 on the D-Sub connection. Ground from this supply should only be connected to pin 70 of the D-Sub connection.

I/O Setup

NOTE: Each DGM is set as the primary or secondary DGM by setting the rotary switch (AG) position. See **Setup** on page 14.

NOTICE

To avoid ground loops and noise immunity issues, do not ground the shield of the D-sub connector cable. The shield is already grounded through the mounting screw on the base of the DGM. If using a breakout board, do not make any connections to the pins with ground symbols.

See the Digital and Analog I/O Overview sections beginning on the following page for I/O setup details. See the **Primary DGM Pin Assignments** and **Secondary DGM Pin Assignments** sections beginning on page 10 for individual pin assignments.

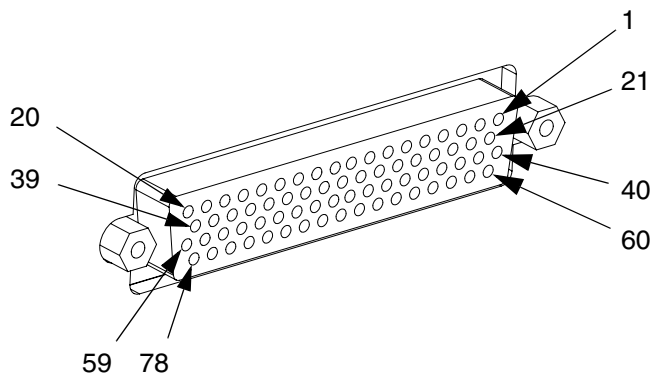
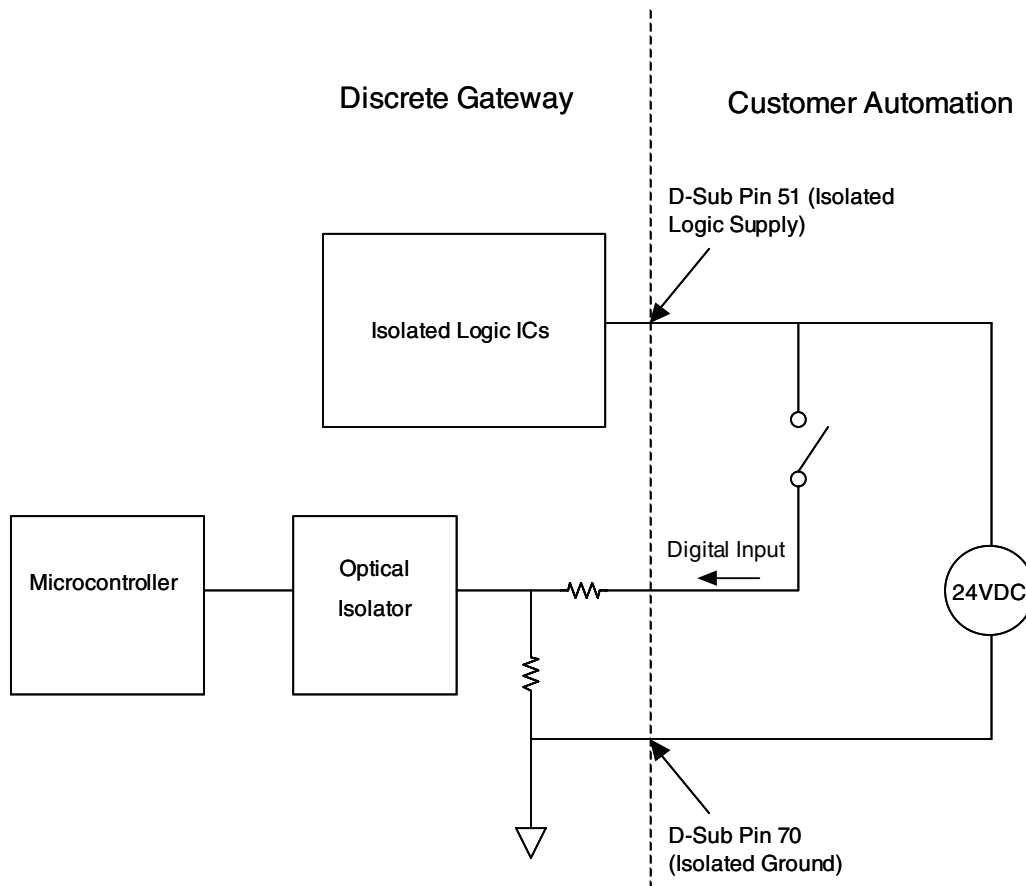

FIG. 3: D-sub Connector - Pin References

DGM Digital Input Overview

The digital inputs function only when power is supplied to pin 51 and there is a ground connection to pin 70. The digital input is rated at 0-30 VDC, and requires an NEC Class 2 power supply connected to pin 51. The DGM provides optical isolation as shown in the following illustration.

- Pins: 52 – 59, 71-78
- Type: Sinking
- Maximum current draw: 3.6 mA



DGM Digital Outputs Overview

The digital outputs function only when power is supplied to pins 27, 68, and 69 and there is a ground connection to pin 70. The digital output is rated at 0-30 VDC, and requires an NEC Class 2 power supply connected to pin 27 for supply bank 1, pin 69 for supply bank 2, and pin 68 for supply bank 3. The DGM provides optical isolation as shown in the following illustration.

- Pins: 9-20, 28-39
- Type: Sourcing
- Maximum continuous current output: 350 mA (sourced from customer supply)
- Recommended continuous current: 100 mA

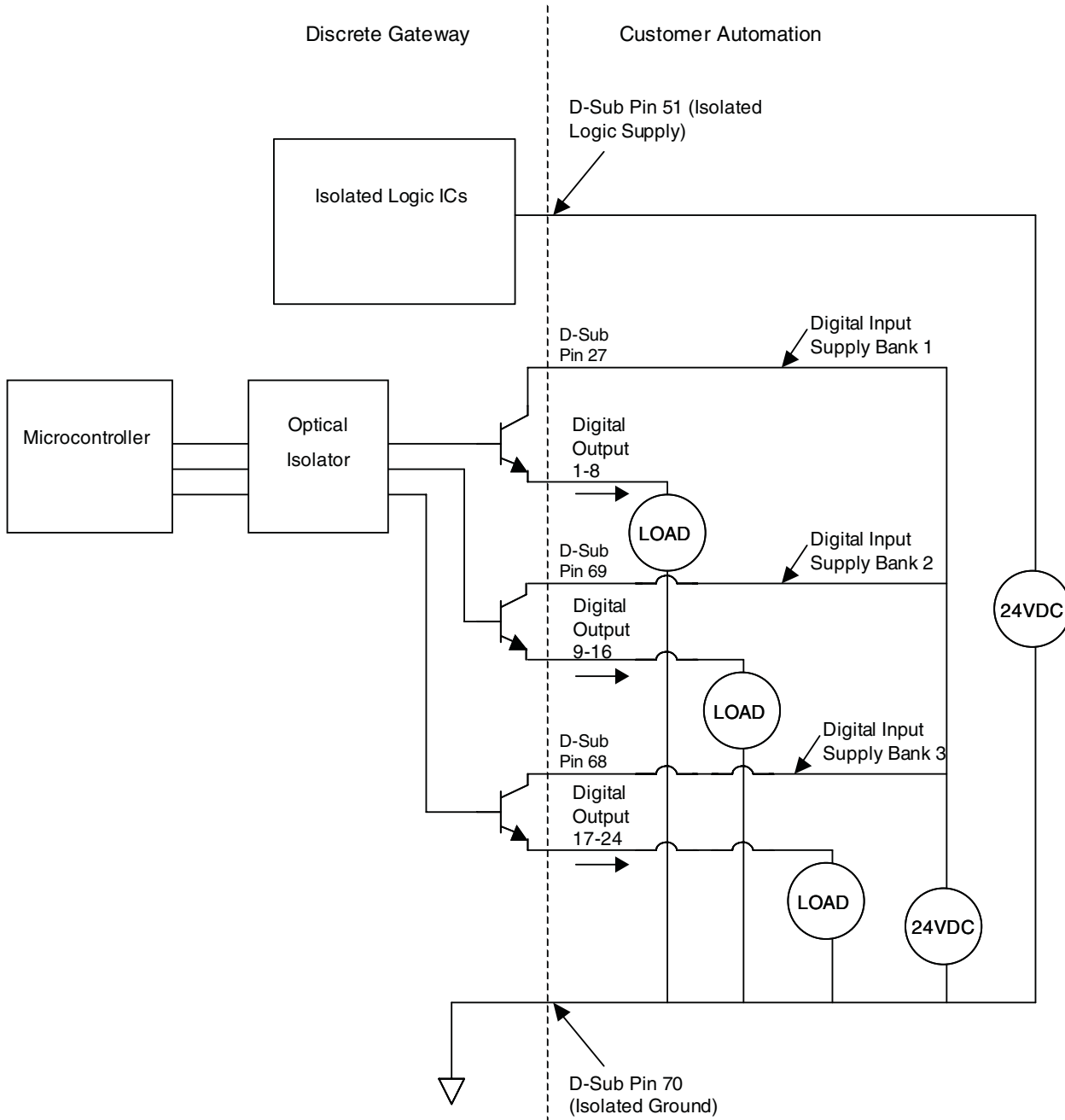

DGM Analog Inputs Overview

The analog inputs function only when the DGM is connected to a power supply through the CAN connection; see **Setup**, page 14. Each analog input has a corresponding reference (ground) pin.

- Type: Sinking
- Voltage Rating: 0-10 Vdc
- Input Impedance: 20 k Ω

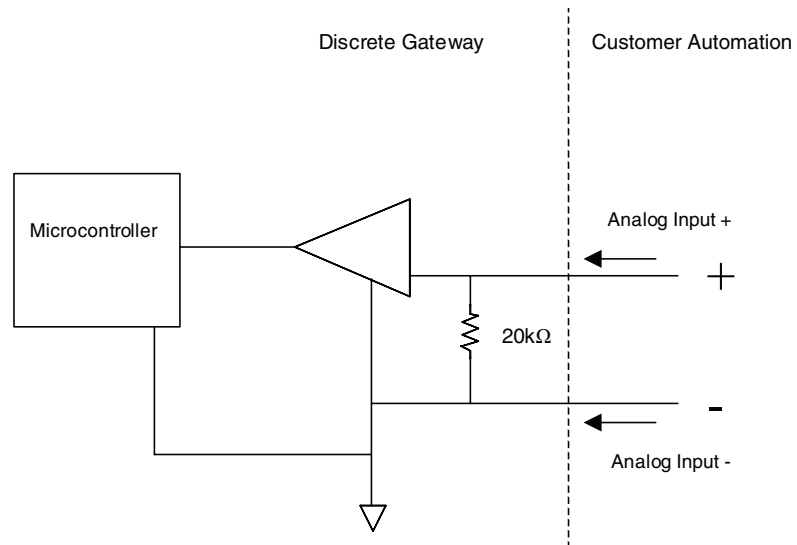

DGM Analog Outputs Overview

The analog outputs function only when the DGM is connected to a power supply through the CAN connection; see **Setup** on page 14. Each analog output has a corresponding reference (ground) pin.

- Type: Sourcing
- Voltage Rating: 0-10 Vdc, 10 mA at 10 Vdc

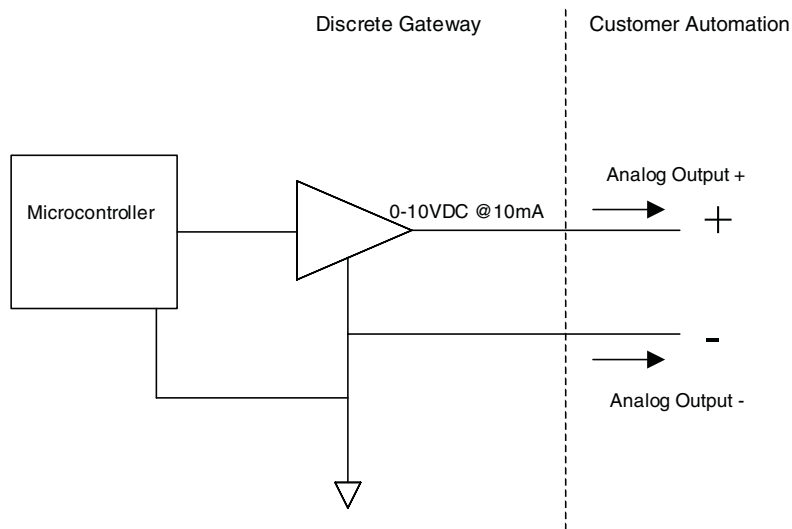

Primary DGM Pin Assignments

Pin Number	DGM Digital Inputs	Functional Description
52	1	PLC to DGM Heartbeat
53	2	Dispense Request / Terminate (Shot, Operator modes), or Start/Stop Recirculation (Standby Mode)
54	3	System Stop
55	4	Acknowledge Active Error
56	5	Set Operating Mode, Bit 2
57	6	Set Operating Mode, Bit 1
58	7	Set Operating Mode, Bit 0
59	8	Accept Operating Mode Change
71	9	Select Shot, Bit 6 (Shot Mode)
72	10	Select Shot, Bit 5 (Shot Mode)
73	11	Select Shot, Bit 4 (Shot Mode)
74	12	Select Shot, Bit 3 (Shot Mode), or Enable Dispensing (Active Low)
75	13	Select Shot, Bit 2 (Shot Mode), or Enable ADM (System in Disabled mode)
76	14	Select Shot, Bit 1 (Shot Mode), or Lock/Unlock the Dispense Valve (Standby Mode)
77	15	Select Shot, Bit 0 (Shot Mode), or Open/Close Dispense Valve (Standby Mode)
78	16	Accepted Selected Shot (Shot Mode), or Accepted Pressure/Flow (Operator Mode), or Park Pump (Standby Mode)

Pin Number	DGM Digital Outputs	Functional Description
9	1	DGM to PLC Heartbeat
10	2	Ready to Dispense
11	3	Dispense in Progress
12	4	Requested Flow Rate/Pressure Setpoint Rejected
13	5	Dispense Mode Selected: Flow (Low) or Pressure (High)
14	6	Error Present
15	7	Fault Code, Bit 7
16	8	Fault Code, Bit 6
17	9	Fault Code, Bit 5
18	10	Fault Code, Bit 4
19	11	Fault Code, Bit 3
20	12	Fault Code, Bit 2
28	13	Fault Code, Bit 1
29	14	Fault Code, Bit 0
30	15	Operating Mode Selected, Bit 2
31	16	Operating Mode Selected, Bit 1
32	17	Operating Mode Selected, Bit 0
33	18	Shot Selected, Bit 6
34	19	Shot Selected, Bit 5
35	20	Shot Selected, Bit 4
36	21	Shot Selected, Bit 3
37	22	Shot Selected, Bit 2 (Shot Mode), or Dispense Valve Locked (Standby Mode)
38	23	Shot Selected, Bit 1 (Shot Mode), or Dispense Valve Open (Standby Mode)
39	24	Shot Selected, Bit 0 (Shot Mode), or Pump Parked (Standby Mode)

Pin Number	DGM Analog Inputs	Functional Description
1	1	Set B (Blue) Pump Dispensing Pressure or Combined Dispensing Flow Rate
2	1 - GND	Grounding Pin for Analog Input 1
3	2	Not Used
4	2 - GND	Not Used
21	3	Not Used
22	3 - GND	Not Used
23	4	Not Used
24	4 - GND	Not Used

Pin Number	DGM Analog Outputs	Functional Description
40	1	B (Blue) Pump Pressure
41	1 - GND	Grounding Pin for Analog Output 1
42	2	A (Red) Pump Pressure
43	2 - GND	Grounding Pin for Analog Output 2
60	3	Combined Flow Rate or B (Blue) Pump Pressure
61	3 - GND	Grounding Pin for Analog Output 3
62	4	Not Used
63	4 - GND	Not Used

Pin Number	Power Supply	Functional Description
27	+	9-30V Power Supply Pins
51		
68		
69		
70	-	Grounding Pin

Secondary DGM Pin Assignments

Pin Number	DGM Digital Inputs	Functional Description	Pin Number	DGM Digital Outputs	Functional Description
52	1	Set Zone 1 On	9	1	Not Used
53	2	Set Zone 2 On	10	2	Ready To Dispense
54	3	Set Zone 3 On	11	3	Dispense in Progress
55	4	Set Zone 4 On	12	4	Zone 1 On
56	5	Accept Zone 1 Setpoint Change	13	5	Zone 2 On
57	6	Accept Zone 2 Setpoint Change	14	6	Zone 3 On
58	7	Accept Zone 3 Setpoint Change	15	7	Zone 4 On
59	8	Accept Zone 4 Setpoint Change	16	8	Zone 1 Temperature Setpoint Rejected
71	9	Not Used	17	9	Zone 2 Temperature Setpoint Rejected
72	10	Not Used	18	10	Zone 3 Temperature Setpoint Rejected
73	11	Not Used	19	11	Zone 4 Temperature Setpoint Rejected
74	12	Not Used	20	12	Tank Heater A (Red) Enabled
75	13	Not Used	28	13	Tank Heater B (Blue) Enabled
76	14	Not Used	29	14	Inline Heater A (Red) Enabled
77	15	Not Used	30	15	Inline Heater B (Blue) Enabled
78	16	Not Used	31	16	Hose Heater A (Red) Enabled
			32	17	Hose Heater B (Blue) Enabled
			33	18	Chiller A (Red) Enabled
			34	19	Chiller B (Blue) Enabled
			35	20	Not Used
			36	21	Not Used
			37	22	Not Used
			38	23	Not Used
			39	24	Not Used

Pin Number	DGM Analog Inputs	Functional Description
1	1	Set Zone 1 Temperature
2	1 - GND	Grounding Pin for Analog Input 1
3	2	Set Zone 2 Temperature
4	2 - GND	Grounding Pin for Analog Input 2
21	3	Set Zone 3 Temperature
22	3 - GND	Grounding Pin for Analog Input 3
23	4	Set Zone 4 Temperature
24	4 - GND	Grounding Pin for Analog Input 4

Pin Number	DGM Analog Outputs	Functional Description
40	1	Actual Zone 1 Temperature
41	1 - GND	Grounding Pin for Analog Output 1
42	2	Actual Zone 2 Temperature
43	2 - GND	Grounding Pin for Analog Output 2
60	3	Actual Zone 3 Temperature
61	3 - GND	Grounding Pin for Analog Output 3
62	4	Actual Zone 4 Temperature
63	4 - GND	Grounding Pin for Analog Output 4

Pin Number	Power Supply	Functional Description
27	+	9-30V Power Supply Pins
51		
68		
69		
70	-	Grounding Pin

Setup

See **Typical Installation** on page 4 for an assembled view.

1. Install the DGM in the desired location.
 - a. Remove access cover (AD).

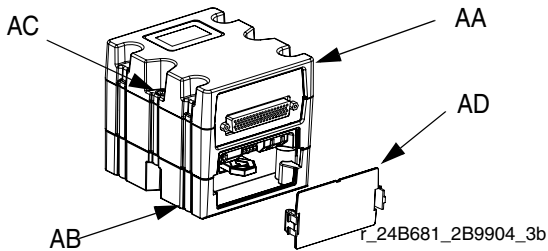
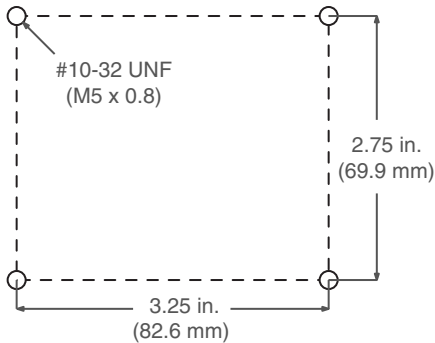

FIG. 4

- b. Loosen two screws (AC) and remove DGM (AA) from base (AB).
- c. Attach ground wire to bottom of base.
- d. Mount base (AB) in desired location with four screws. See the following mounting dimensions.



- e. Insert screws through top of base and tighten.
- f. Insert screw through ground wire and tighten.
- g. Mount DGM (AA) on base (AB) with two screws (C).
- h. If applicable, repeat with second DGM.

2. Adjust DGM selector switch (AG) according to the following table.

Setting	Zone
1	Primary DGM
2	Secondary DGM

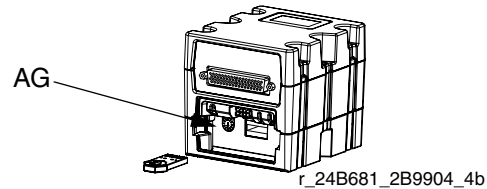

3. Install access cover (D).
4. Connect CAN and D-Sub cables.

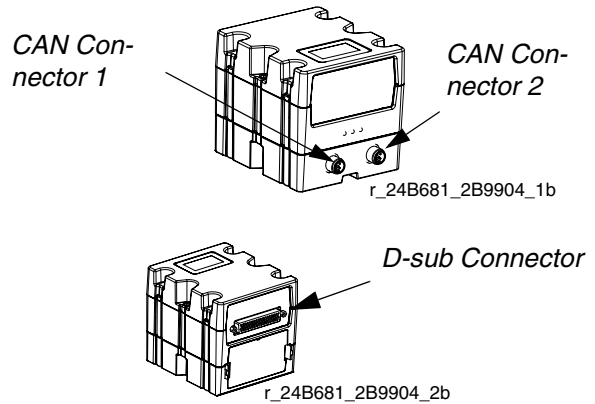

FIG. 5: Cable Connections

- a. Connect CAN cable from Connector 1 on DGM to ADM or any available CAN connection on the machine. Attach the ferrite suppressor to DGM end of the CAN cable.

NOTE: In the previous step if more than one DGM is used the connection can be made with either DGM.

- b. If a second DGM is installed, connect CAN cable from CAN Connector 1 on the second DGM to Connector 2 on the first DGM.

- c. Connect D-Sub cable from D-Sub Connector on first DGM to a breakout board or to an external control device.
- d. If second DGM is installed, connect D-Sub cable from D-Sub Connector on second DGM to a breakout board or to an external control device.

Operation

Primary DGM Digital Inputs

See DGM Digital Inputs table in the **Primary DGM Pin Assignments** section beginning on page 10 for pin numbers associated with each bit description.

The primary DGM allows the PLC to control and monitor the HFR's dispensing properties.

Digital Input 1: PLC to DGM Heartbeat

The external control device (PLC) and DGM will each have Heartbeat inputs and outputs. The heartbeat serves as a verification that both devices are communicating. The PLC does not need to implement any timers to regulate the period of the heartbeat. To successfully complete a heartbeat, the PLC must match the output state of the DGM heartbeat. This can happen as soon as the PLC detects the change in output state, or within 6 seconds of detecting a change in heartbeat state. If the PLC does not match the output state of the DGM after 6 seconds, the DGM will disable the system. This will only happen once, and the HFR can be reactivated and operated from the ADM. The DGM will not accept any more requests until the heartbeat resumes between the PLC and DGM.

Digital Input Bit 2

The function of this bit is based on the selected operating mode:

NOTE: The Enable Dispensing bit must be pulled low prior to dispensing.

- **Shot Mode:** Toggle this bit high to dispense a single shot. Toggle the bit in the middle of a shot to terminate the dispense.
- **Operator Mode:** The machine will dispense while the bit is pulled high. As soon as the bit falls low, the dispense terminates.
- **Operator Mode with Fusion[®] Gun:** Toggle this bit to stop/start stalling the system to pressure.
- **Standby Mode:** Toggle this bit high to start/stop recirculation (recirculation systems only).

Digital Input 3: System Stop

Toggle this bit high to place the dispensing system in disabled mode.

Digital Input 4: Acknowledge Active Error

Toggle this bit high to acknowledge any errors detected by the system.

Digital Inputs 5-7: Set Operating Mode Bits

The operating mode is selected through the use of 3 bits. The following table describes the bit pattern to indicate selection of each operating mode. A "1" means the bit is high and a "0" means the bit is low.

Operating Mode Bit Pattern			Operating Mode
Digital Input 5	Digital Input 6	Digital Input 7	
0	0	1	Disabled
0	1	0	Standby
0	1	1	Shot*
1	0	1	Operator
1	1	1	Night**

Digital Input 8: Accept Operating Mode Change

Toggle this bit high while the bit pattern is set to change the operating mode. After toggling this bit, use the analog output bits to verify the operating mode was successfully changed.

* *Shot definitions must be configured through the ADM.*

** *Night mode settings must be configured through the ADM.*

Digital Inputs 9-15: Select Shot Bits

The shot selection bits are used to select one of the 100 different defined shots. The user must use the ADM to define each shot. The DGM will use a 7-bit pattern to select one of the shots.

The machine must be in Shot mode to select a shot.

Shot Selection Bit Pattern							Shot Selected
Digital Input 9	Digital Input 10	Digital Input 11	Digital Input 12	Digital Input 13	Digital Input 14	Digital Input 15	
0	0	0	0	0	0	0	Not Defined
0	0	0	0	0	0	1	Shot 1
0	0	0	0	0	1	0	Shot 2
0	0	0	0	0	1	1	Shot 3
...							
1	1	0	0	1	0	0	Shot 100
1	1	0	0	1	0	1	Not Defined
...							
1	1	1	1	1	1	1	Not Defined

Digital Inputs 12-15 have alternate functionality in Operator, Shot and Standby modes. Below are their alternate functions:

Digital Input 12 becomes:

(used in Operator, Shot, and Standby modes)

- **Enable Dispensing:** Keep this bit low when not selecting a shot. If this bit is high during a dispense request or park pump request, the request will be ignored. If this bit goes high during a dispense the system will go into Disabled mode.

Digital Input 13 becomes:

(used in Disabled mode)

- **Enable ADM:** Toggle this bit to enable the ADM.

Digital Input 14 becomes:

(used in Standby mode)

- **Dispense Valve Open:** While this bit is pulled high the dispense valve will remain open. When it is pulled low the dispense valve will be closed.

Digital Input 15 becomes:

(used in Standby mode)

- **Set/Release Dispense Valve Lock:** Toggle this bit high to lock or unlock the dispense valve in Standby Mode.

Digital Input 16

The function of this bit is based on the selected operating mode:

- **Shot Mode:** Sets the shot number. To use, set the Shot Selection Bits to the desired bit pattern then toggle this bit low then high then low to change the shot. After toggling this bit, the PLC programmer should verify that the current shot number matches the request.
- **Operator Mode:** Sets the dispense pressure or flow. To use, set Analog Input 1: Set Pressure/Set Flow to the voltage for the corresponding desire flow or pressure. After 185 mS of settling, toggle this bit to set the new analog value. The PLC programmer should check Digital Output 4 to make sure the set-point was accepted.

See the **Primary DGM Analog Inputs** section on page 19 for analog input voltage calculation.
- **Standby Mode:** Hold the bit high to park the pump. Use the Digital Output 24 to verify the pump has successfully parked. Release the bit when the pump is successfully parked.

Primary DGM Digital Outputs

See DGM Digital Outputs table in the **Primary DGM Pin Assignments** section beginning on page 10 for pin numbers associated with each bit description.

Digital Output 1: DGM to PLC Heartbeat

See the DGM to PLC Heartbeat description in the **Primary DGM Digital Inputs** section beginning on page 16.

Digital Output 2: Ready To Dispense

For Fusion® dispense guns: This bit is high when the system is stalled to pressure.

For all other dispense guns: This bit is high when the system is ready to begin dispensing.

Digital Output 3: Dispense In Progress

This bit is high when the machine is dispensing.

Digital Output 4: Flow Rate/Pressure Setpoint Rejected

This bit is high when the requested setpoint change is rejected.

Digital Output 5: Dispense Mode Selected

When this bit is low, the selected Dispense mode is Flow. When this bit is high, the selected Dispense mode is Pressure.

Digital Output 6: Error Present

If an error is generated this output will be high. The PLC programmer should monitor the Fault Code bits to determine if the system is in a healthy state but this will serve as an additional and redundant alert.

Digital Output 7-14: Fault Codes

This 8-bit pattern indicates what error is being displayed. See the **Fault Code Bit Pattern Table** on page 30. The fault code is removed when it is acknowledged. For best results, check the ADM.

Digital Output 15-17: Operating Mode Selected Bits

These bits form a bit pattern to indicate which operating mode is selected. See the operating mode bit patterns table in the **Primary DGM Digital Inputs** section beginning on page 16.

Digital Outputs 18-24: Shot Selected Bits

When in Shot mode, these bits are used to form a bit pattern to indicate which shot is selected. See the shot selection bit patterns table in the **Primary DGM Digital Inputs** section beginning on page 16.

When in Standby mode, Digital Outputs 22-24 each perform a different function:

Digital Output 22:

- **Dispense Valve Locked:** This bit is high when the dispense valve is locked.

Digital Output 23:

- **Dispense Valve Open:** This bit is high when the dispense valve is open.

Digital Output 24:

- **Pump Parked:** This bit is high when the pump is in the parked position.

Primary DGM Analog Inputs

See Analog Inputs table in the **Primary DGM Pin Assignments** section beginning on page 10 for pin numbers associated with each bit description.

The DGM provides 4 analog inputs and 4 analog outputs. Each analog I/O point has a voltage range of 0-10 VDC. Analog Inputs 2, 3, and 4 are not used.

It is the responsibility of the PLC programmer to verify the HFR system and PLC have matching values for pump sizes, material specific gravities, maximum working pressure, and units of measure for pressure. These are verified using the Setup screens in the ADM.

Analog Input 1: Set Combined Flow Rate or B (Blue) Dispensing Pressure

To calculate the input voltage for the desired flow or pressure, use the following formulas.

Volumetric Flow:

$$V = (10 \times F_v) / (A_p + B_p)$$

Weight Flow:

$$V = (10 \times F_w) / (A_p \times A_{sg} + B_p \times B_{sg})$$

Pressure:

$$V = (10 \times P_d) / (P_{mwp})$$

where,

V = Voltage

A_p = A (Red) pump size in cc

B_p = B (Blue) pump size in cc

A_{sg} = A (Red) material specific gravity

B_{sg} = B (Blue) material specific gravity

F_v = Desired volumetric flow rate in cc per second

F_w = Desired flow rate in grams per second

P_d = Desired pressure

P_{mwp} = Maximum working pressure

For example, if the A (Red) pump is 120 cc, the B (Blue) pump is 160 cc, and the desired flow rate is 180 cc per second then:

$$V = (10 \times 180) / (120 + 160) \\ = 6.43 \text{ volts}$$

If the A (Red) pump is 120 cc, the A (Red) specific gravity is 1.09, the B (Blue) pump is 160 cc, the B (Blue) specific gravity is 1.21, and the desired flow rate is 200 grams per second then:

$$V = (10 \times 200) / (120 \times 1.09 + 160 \times 1.21) \\ = 6.17 \text{ volts}$$

If the desired pressure is 1500 psi and the maximum working pressure is 2000 psi then:

$$P_d = 1250 \\ P_{mwp} = 2000$$

$$V = (10 \times 1500) / (2000) \\ = 7.5 \text{ volts}$$

To set the flow or pressure:

1. Calculate the voltage to use.
2. Set the Analog Input 1 to the calculated voltage and hold.
3. After 185 mS, pull the corresponding Digital Input 16 bit for 185 mS then release Digital Input 16.
4. Check Digital Output 4 to verify the setpoint request was not rejected.

Primary DGM Analog Outputs

See Analog Outputs table in the **Primary DGM Pin Assignments** section beginning on page 10 for pin numbers associated with each function. Each analog I/O point has a voltage range of 0-10 VDC. The primary DGM analog outputs are used to provide feedback regarding operating pressures and flows.

Analog Output 1: B (Blue) Pump Pressure and Analog Output 2: A (Red) Pump Pressure

An analog voltage representation of the pump pressure will be presented at the respective output. The DGM will use the 0-10V range to represent pressures from 0 to 500 psi plus the maximum working pressure. Due to this limit, pressures beyond 500 psi above the maximum working pressure will be represented as 10V.

To calculate the pump pressure based on the output voltage, the maximum working pressure must be known. See the HFR system manual to determine the system maximum working pressure.

When units of measure are psi:

$$P_a = 0.1 \times V \times (P_{mwp} + 500)$$

When units of measure are bar:

$$P_a = 0.1 \times V \times (P_{mwp} + 34.5)$$

When units of measure are MPa:

$$P_a = 0.1 \times V \times (P_{mwp} + 3.45)$$

where,

V = Voltage

P_a = Actual pump pressure

P_{mwp} = Maximum working pressure

For example, if the output voltage is 6 and the maximum working pressure is 2000 psi then:

$$\begin{aligned} P_a &= 0.1 \times 6 \times (2000 + 500) \\ &= 1500 \text{ psi} \end{aligned}$$

Analog Output 3: B (Blue) Pressure or Combined Flow Rate

To use the Analog Output 3 voltage to calculate the B (Blue) pump pressure or combined flow rate, use the following formulas.

Volumetric Flow:

$$F_v = 0.1 \times V \times (A_p + B_p)$$

Weight Flow:

$$F_w = 0.1 \times V \times (A_p \times A_{sg} + B_p \times B_{sg})$$

Pressure:

When units of measure are psi:

$$P_a = 0.1 \times V \times (P_{mwp} + 500)$$

When units of measure are bar:

$$P_a = 0.1 \times V \times (P_{mwp} + 34.5)$$

When units of measure are MPa:

$$P_a = 0.1 \times V \times (P_{mwp} + 3.45)$$

where

F_v = Actual volumetric flow rate in cc per second

F_w = Actual flow rate in grams per second

P_a = Actual B (Blue) pump pressure

V = Voltage

A_p = A (Red) pump size in cc

B_p = B (Blue) pump size in cc

A_{sg} = A (Red) material specific gravity

B_{sg} = B (Blue) material specific gravity

P_{mwp} = Maximum working pressure

For example, if the A (Red) pump is 120 cc, the B (Blue) pump is 160 cc, and the output voltage is 2.3 then:

$$\begin{aligned} F_v &= 0.1 \times 2.3 \times (120 + 160) \\ &= 64.4 \text{ cc/sec} \end{aligned}$$

If the A (Red) pump is 120 cc, the A (Red) specific gravity is 1.09, the B (Blue) pump is 240 cc, the B (Blue) specific gravity is 1.21, and the output voltage is 2.3 then:

$$\begin{aligned} F_w &= 0.1 \times 2.3 \times (120 \times 1.09 + 160 \times 1.21) \\ &= 74.6 \text{ g/sec} \end{aligned}$$

If the output voltage is 6 and the maximum working pressure is 2000 psi then:

$$\begin{aligned} P_a &= 0.1 \times 6 \times (2000 + 500) \\ &= 1500 \text{ psi} \end{aligned}$$

Secondary DGM I/O Overview

The secondary DGM is used for controlling and monitoring the status of the heaters and chillers.

NOTE: The HFR has a total of 8 possible conditioning zones that can be implemented in the system. In any given instance, a maximum of 4 conditioning zones can be enabled.

Each temperature conditioning item is assigned a zone number. Most temperature conditioning bits relate to a zone number rather than to a specific temperature conditioning item's name. Knowing the correct zone number is important for desired machine operation. The zone numbers are always assigned in the order shown in the following table. Going down the list, the first enabled item is zone 1, the second is zone 2, the third is zone 3, and the fourth is zone 4.

NOTE: There will be less than four zones if less than four temperature conditioning items are installed or enabled on the ADM.

Order	Temperature Conditioning Item
1	Tank Heater, A (Red)
2	Tank Heater, B (Blue)
3	Inline Heater, A (Red)
4	Inline Heater, B (Blue)
5	Hose Heater, A (Red)
6	Hose Heater, B (Blue)
7	Chiller, A (Red)
8	Chiller, B (Blue)

The following is an example of a system with Tank Heater A (Red), Inline Heater B (Blue), Hose Heater B (Blue), and Chiller A (Red) enabled and shows the assigned zone numbers for each.

Zone	Order	Temperature Conditioning Item
1	1	Tank Heater, A (Red)
	2	Tank Heater, B (Blue)
	3	Inline Heater, A (Red)
2	4	Inline Heater, B (Blue)
	5	Hose Heater, A (Red)
3	6	Hose Heater, B (Blue)
4	7	Chiller, A (Red)
	8	Chiller, B (Blue)

See the **Secondary DGM Digital Outputs** section beginning on page 22 for information about finding out which temperature conditioning components are enabled.

Secondary DGM Digital Inputs

Digital Inputs 1-4: Toggle Zone Conditioning On/Off Bits

Pulling this input high turns the zone on. Pulling it low turns the zone off. It is also possible to control the zones using the ADM.

Digital Inputs 5-8: Accept Zone Setpoint Change Bits

NOTE: This function is only available on 2nd Generation ADM's.

Toggle one of these bits high to tell the DGM to set the new zone setpoint based on the corresponding analog input voltage. See **Secondary DGM Analog Inputs** on page 23 for voltage calculation and procedure for changing the setpoint.

Secondary DGM Digital Outputs

Digital Output 2: Ready To Dispense

The ADM can be configured to prevent dispensing if the conditioning zones are not the correct temperature. If this feature is enabled, this bit will be low when at least one temperature zone is not up to temperature.

NOTE: This bit gets pulled low during a dispense.

Digital Output 3: Dispense in Progress

This bit is high when a dispense is in progress.

Digital Outputs 4-7: Zone Conditioning On

When one of these bits is high, it indicates that the respective heater/chiller in that zone is on.

Digital Outputs 8-11: Zone Temperature Setpoint Rejected

This bit indicates the requested setpoint has been rejected. This occurs when the requested setpoint is too high or low. This bit should be checked after requesting to change a setpoint to verify that the setpoint was accepted.

NOTE: Changing the setpoint on the ADM does not affect this bit.

Digital Outputs 12-19: Temperature Conditioning Component Enabled

When one of these bits is high, the corresponding temperature conditioning component is enabled.

Secondary DGM Analog Inputs

Set Zone Temperature

The external control device interfacing with the DGM can use a varying voltage to specify the desired setpoint for the zone. See **Secondary DGM Pin Assignments** on page 12.

To calculate the voltage to use based on the desired temperature in degrees Fahrenheit:

$$\text{Voltage} = 0.074 \times \text{°F} - 4.074$$

For example, the voltage for 86°F would be:

$$\begin{aligned}\text{Voltage} &= 0.074 \times 86 - 4.074 \\ &= 2.29\end{aligned}$$

To calculate the voltage to use based on the desired temperature in degrees Celsius:

$$\text{Voltage} = 0.133 \times \text{°C} - 1.707$$

For example, the voltage for 30°C would be:

$$\begin{aligned}\text{Voltage} &= 0.133 \times 30 - 1.707 \\ &= 2.28\end{aligned}$$

To set the zone temperature:

1. Calculate the voltage to use.
2. Set the desired “Set Zone Temperature” Analog Input to the calculated voltage and hold.
3. After 185 mS, pull high the corresponding “Accept Zone Setpoint Change” Digital Input for 185 mS then release.
4. Check the Zone Temperature Setpoint Rejected bit. If it is asserted, check the ADM.

Secondary DGM Analog Outputs

Actual Zone Temperature

The analog output voltages indicate the actual temperature of the material at the specified zone.

To calculate the temperature in degrees Fahrenheit based on the output voltage:

$$^{\circ}\text{F} = 13.5 \times \text{Voltage} + 55$$

For example, if the output voltage is 2.3 then:

$$\begin{aligned} ^{\circ}\text{F} &= 13.5 \times 2.3 + 55 \\ &= 86^{\circ}\text{F} \end{aligned}$$

To calculate the temperature in degrees Celsius based on the output voltage:

$$^{\circ}\text{C} = 7.5 \times \text{Voltage} + 12.8$$

For example, if the output voltage is 2.3 then:

$$\begin{aligned} ^{\circ}\text{C} &= 7.5 \times 2.3 + 12.8 \\ &= 30^{\circ}\text{C} \end{aligned}$$

Timing Diagrams

Once the last line has been set in any of the following timing diagrams, a 10 mS settle time should be observed to allow the PLC and DGM hardware to reach a steady state.

Heartbeat

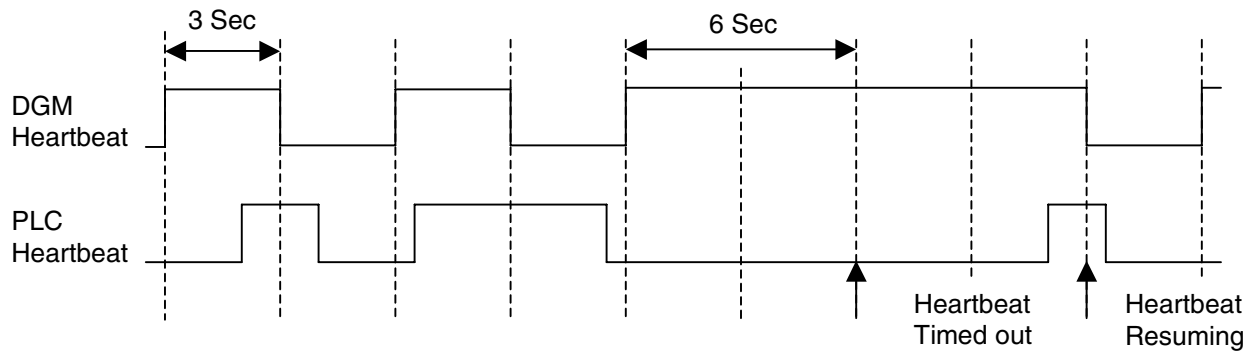

FIG. 6: Heartbeat Timing Diagram

Activate System Stop Button

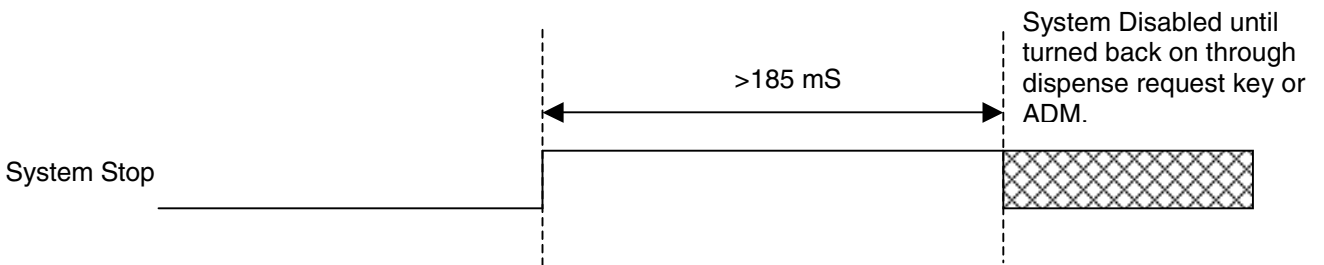

FIG. 7: Activate System Stop Button Timing Diagram

System Requests

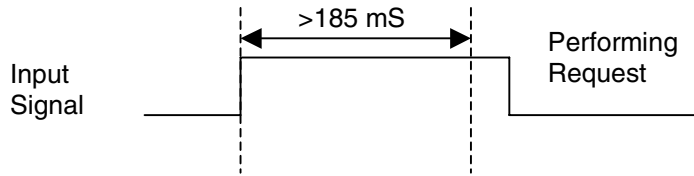

FIG. 8: System Requests Timing Diagram

The following are system requests:

- Enabling the ADM
- Acknowledging Errors
- Parking the pump

Select an Operating Mode or Shot Number

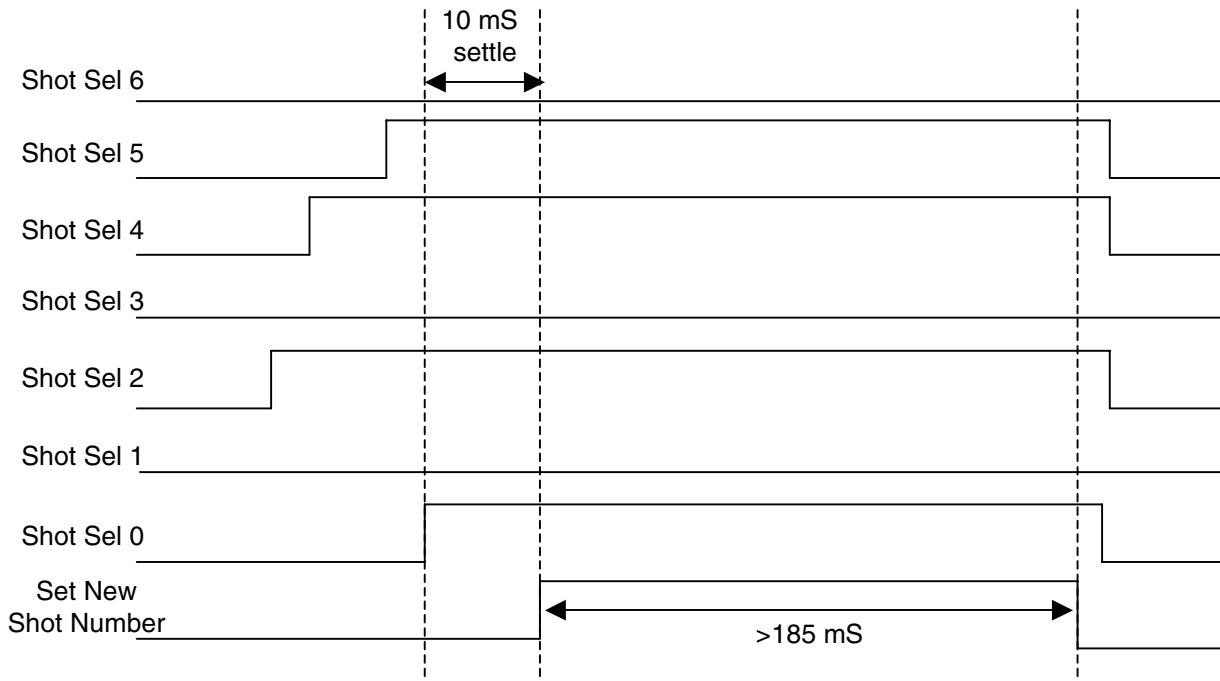

FIG. 9: Select a Shot Number Timing Diagram

The individual lines can change independently in any order.

Change Setpoint

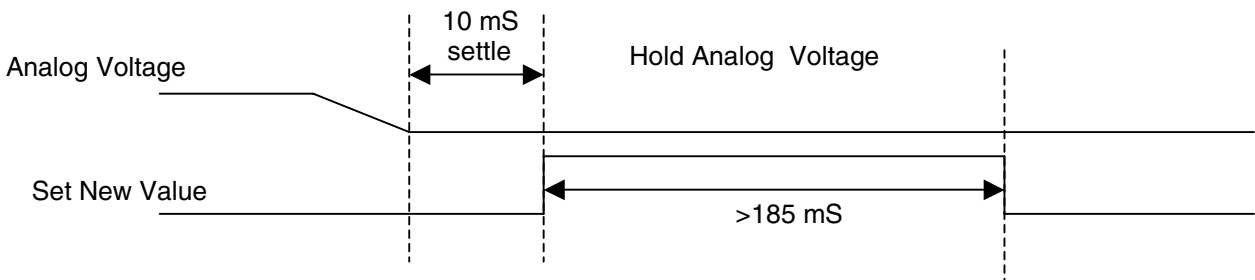

FIG. 10: Change Setpoint Timing Diagram

This procedure applies to the following functions:

- Changing the dispense pressure setpoint
- Changing the material temperature setpoint

Toggle On/Off

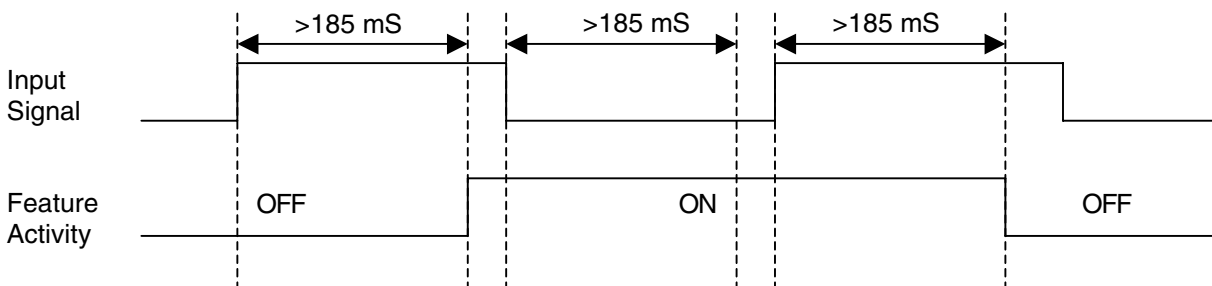

FIG. 11: Toggle On/Off Timing Diagram

This diagram applies to the following functions:

- Open/Close the Dispense Valve
- Lock/Unlock the Dispense Valve
- Activate/Deactivate the Hydraulic Power Pack

Operator Mode Dispense

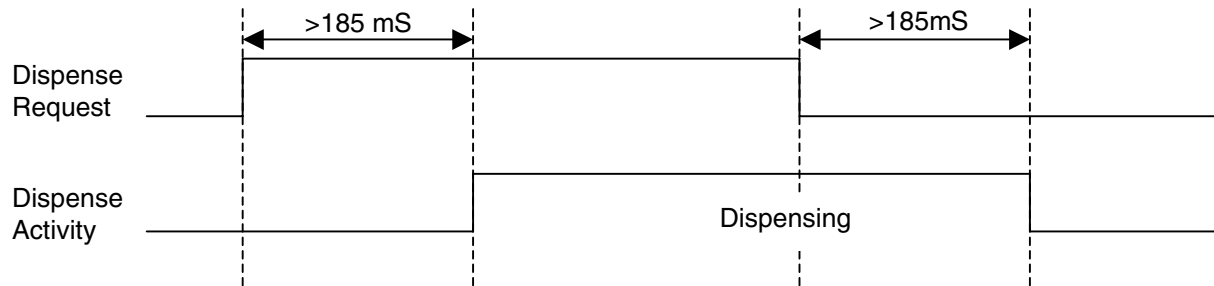

FIG. 12: Operator Mode Dispense Timing Diagram

Maintenance

Install Upgrade Token

Note: The DGM connection to the system is temporarily disabled during the installation of the upgrade token.

To install software upgrades:

1. Use correct software token stated in the table. See Graco Control Architecture™ Module Programming manual for instructions.

NOTE: Upgrade all modules in the system to the software version on the token, even if you are replacing only one or two modules. Different software versions may not be compatible.

All data in the module (System Settings, USB Logs, Recipes, Maintenance Counters) may be reset to factory default settings. Download all settings and user preferences to a USB before the upgrade, for ease of restoring them following the upgrade.

See manuals for locations of specific GCA components.

The software version history for each system can be viewed in the technical support section at www.graco.com.

Token	Application
16H821	HFR: <ul style="list-style-type: none"> - Advanced Display Module - Motor Control Module - High Power Temperature Control Module - Fluid Control Module (AC Power Pack) - Discrete Gateway Module - Communication Gateway Module

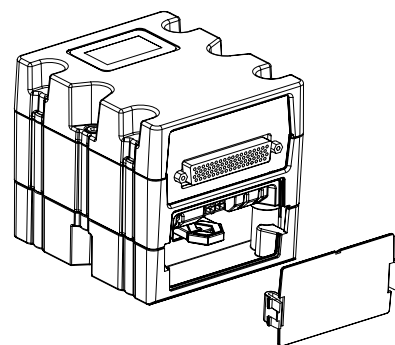

FIG. 13

Check Cable Connections

Ensure all cables are securely connected to DGM connectors.

Troubleshooting

Diagnostic Information

Module Status LED Signal	Diagnosis
Green on	System is powered up
Yellow	Internal communication in progress
Red solid	DGM hardware failure, replace DGM
Red flashing fast	Uploading software
Red flashing slow	Token error, remove token then re-install software token

Fault Code Bit Pattern Table

This is an 8-bit pattern indicating the current error number in the system. The bit pattern is accompanied by the Error Present bit.

If the PLC displays error messages, the PLC programmer should translate the bit pattern to the corresponding descriptive string. See the following table to translate the fault code bit pattern to a descriptive string. The Error Number column is used for reference to aid the PLC programmer in translating from fault code bit pattern to error string. When error number 255 with bit pattern "11111111" occurs the user should check the ADM for error details.

NOTE: This manual is available at Graco.com. To prevent having to manually re-type these error codes and strings into your PLC program, go to Graco.com and retrieve the electronic version of this manual then copy the following table from the PDF.

Fault Code Bit Pattern (Bit 7 --> Bit 0)	Error String	Error Number	Error Code Shown on the ADM				
00000000	No Active Errors	0	0	0	0	0	0
00000001	Motor Temp. Shutdown B (Blue)	1	A	T	4	N	1
00000010	Motor Temp. Cutback B (Blue)	2	V	T	3	N	1
00000011	Oil Temp. Shutdown B (Blue)	3	A	T	4	H	1
00000100	Oil Temp. Cutback B (Blue)	4	D	T	3	H	1
00000101	Low Oil Level B (Blue)	5	A	M	B	H	1
00000110	Motor Over Current B (Blue)	6	A	A	4	H	1
00000111	Motor Over Current B (Blue)	7	A	A	4	N	1
00001000	Motor Over Current B (Blue)	8	A	A	4	M	1
00001001	Motor Over Current B (Blue)	9	A	A	9	C	1
00001010	Motor Control High Temp. B (Blue)	10	A	T	4	C	1
00001011	Motor Control Overvoltage B (Blue)	11	A	V	4	H	0
00001100	Motor Control Undervoltage B (Blue)	12	A	V	1	H	1

Fault Code Bit Pattern (Bit 7 --> Bit 0)	Error String	Error Number	Error Code Shown on the ADM				
			A	W	B	H	1
00001101	Motor Encoder Fault B (Blue)	13	A	W	B	H	1
00001110	Motor Controller Fault B (Blue)	14	D	W	M	H	1
00001111	Low Motor Performance B (Blue)	15	V	M	B	N	1
00010000	High Motor Speed B (Blue)	16	A	W	K	H	1
00010001	B (Blue) Pump Failed to Move	17	D	N	4	A	1
00010010	Invalid Setpoint Request	18	D	W	S	C	0
00010011	Small Shot Request	19	D	B	9	C	0
00010100	Pressure Imbalance	20	A	P	4	D	0
00010101	Pumps Not Defined	21	A	D	S	C	0
00010110	Invalid Learn Mode Data B (Blue)	22	D	D	5	A	1
00010111	Invalid Weight Cal. Data	23	D	0	5	0	0
00011000	B (Blue) Position Sensor Fault	24	A	D	6	A	1
00011001	A (Red) Pressure Sensor Fault	25	A	P	6	A	1
00011010	B (Blue) Pressure Sensor Fault	26	A	P	6	B	2
00011011	B (Blue) Setpoint Not Reached	27	D	D	1	A	1
00011100	B (Blue) Setpoint Not Reached	28	D	D	2	A	1
00011101	B (Blue) Setpoint Exceeded	29	D	D	4	A	1
00011110	B (Blue) Setpoint Exceeded	30	D	D	3	A	1
00011111	A (Red) Pressure Shutdown	31	A	P	4	A	1
00100000	B (Blue) Pressure Shutdown	32	A	P	4	B	2
00100001	B (Blue) Pump Not Parked	33	D	D	F	A	1
00100010	B (Blue) Pump Failed to Stall	34	D	F	7	D	1
00100011	Invalid Gel Timer Definition	35	D	W	S	D	0
00100100	A (Red) Pump Cavitation	36	D	D	D	A	1
00100101	B (Blue) Pump Cavitation	37	D	D	D	B	2
00100110	Pressure Terminated Cal.	38	V	P	9	A	1
00100111	Pressure Terminated Cal.	39	V	P	9	B	2
00101000	Flow Terminated Cal.	40	V	D	A	A	1
00101001	Thermal Pressure Rise	41	D	P	4	0	0
00101010	Setpoint Outside Cal. Range	42	V	0	9	C	1
00101011	A (Red) Motor Temp. Shutdown	43	A	T	4	N	2
00101100	A (Red) Motor Temp. Cutback	44	V	T	3	N	2

Fault Code Bit Pattern (Bit 7 --> Bit 0)	Error String	Error Number	Error Code Shown on the ADM				
00101101	A (Red) Oil Temp. Shutdown	45	A	T	4	H	2
00101110	A (Red) Oil Temp. Cutback	46	D	T	3	H	2
00101111	A (Red) Low Oil Level	47	A	M	B	H	2
00110000	A (Red) Motor Over Current	48	A	A	4	H	2
00110001	A (Red) Motor Over Current	49	A	A	4	N	2
00110010	A (Red) Motor Over Current	50	A	A	4	M	2
00110011	A (Red) Motor Over Current	51	A	A	9	C	2
00110100	A (Red) Motor Control High Temp.	52	A	T	4	C	2
00110101	A (Red) Motor Control Overvoltage	53	A	V	4	H	0
00110110	A (Red) Motor Control Undervoltage	54	A	V	1	H	2
00110111	A (Red) Motor Encoder Fault	55	A	W	B	H	2
00111000	A (Red) Motor Controller Fault	56	A	W	M	H	2
00111001	A (Red) Low Motor Performance	57	A	M	B	N	2
00111010	A (Red) High Motor Speed	58	A	W	K	H	2
00111011	A (Red) Pump Failed to Move	59	A	N	4	B	0
00111100	Invalid Requested Ratio	60	A	R	9	C	0
00111101	Invalid Learn Mode Data	61	A	D	5	B	2
00111110	Invalid Auto Cal B (Blue)?	62	0	0	0	0	0
00111111	A (Red) Position Sensor Fault	63	A	D	6	B	2
01000000	A (Red) Setpoint Not Reached	64	D	D	1	A	2
01000001	A (Red) Setpoint Not Reached	65	D	D	2	A	2
01000010	A (Red) Setpoint Exceeded	66	D	D	4	A	2
01000011	A (Red) Setpoint Exceeded	67	D	D	3	A	2
01000100	A (Red) Pressure Shutdown	68	A	P	4	A	1
01000101	A (Red) Pump Not Parked	69	D	D	F	B	2
01000110	A (Red) Pump Failed to Stall	70	A	F	7	D	2
01000111	Another Cal Error?	71	0	0	0	0	0
01001000	A (Red) Thermal Pressure Rise?	72	D	P	4	0	1
01001001	A (Red) Blanket Temp. Cutoff	73	A	T	9	A	6
01001010	B (Blue) Blanket Temp. Cutoff	74	A	T	9	B	5
01001011	A (Red) Inline Temp. Cutoff	75	A	T	9	A	3
01001100	B (Blue) Inline Temp. Cutoff	76	A	T	9	B	1
01001101	No A (Red) Blanket Current	77	A	A	8	A	6
01001110	No B (Blue) Blanket Current	78	A	A	8	B	5
01001111	No A (Red) Inline Current	79	A	A	8	A	3
01010000	No B (Blue) Inline Current	80	A	A	8	B	1
01010001	No A (Red) Hose Current	81	A	A	8	A	2
01010010	No B (Blue) Hose Current	82	A	A	8	B	4
01010011	No A (Red) Chiller Current	83	A	A	8	B	7
01010100	No B (Blue) Chiller Current	84	A	A	8	B	8
01010101	A (Red) Blanket Overcurrent	85	A	A	4	A	6
01010110	B (Blue) Blanket Overcurrent	86	A	A	4	B	5
01010111	A (Red) Inline Overcurrent	87	A	A	4	A	3
01011000	B (Blue) Inline Overcurrent	88	A	A	4	B	1
01011001	A (Red) Hose Overcurrent	89	A	A	4	A	2
01011010	B (Blue) Hose Overcurrent	90	A	A	4	B	4
01011011	A (Red) Chiller Overcurrent	91	A	A	4	A	7
01011100	B (Blue) Chiller Overcurrent	92	A	A	4	B	8
01011101	A (Red) Blanket Control Fault	93	A	A	7	A	6
01011110	B (Blue) Blanket Control Fault	94	A	A	7	B	5
01011111	A (Red) Inline Control Fault	95	A	A	7	A	3
01100000	B (Blue) Inline Control Fault	96	A	A	7	B	1
01100001	A (Red) Hose Control Fault	97	A	A	7	A	2
01100010	B (Blue) Hose Control Fault	98	A	A	7	B	4

Fault Code Bit Pattern (Bit 7 --> Bit 0)	Error String	Error Number	Error Code Shown on the ADM				
01100011	A (Red) Chiller Control Fault	99	A	A	7	A	7
01100100	B (Blue) Chiller Control Fault	100	A	A	7	B	8
01100101	A (Red) Blanket Overvoltage	101	A	V	4	A	6
01100110	B (Blue) Blanket Overvoltage	102	A	V	4	B	5
01100111	A (Red) Inline Overvoltage	103	A	V	4	A	3
01101000	B (Blue) Inline Overvoltage	104	A	V	4	B	1
01101001	A (Red) Hose Overvoltage	105	A	V	4	A	2
01101010	B (Blue) Hose Overvoltage	106	A	V	4	B	4
01101011	A (Red) Chiller Overvoltage	107	A	V	4	A	7
01101100	B (Blue) Chiller Overvoltage	108	A	V	4	B	8
01101101	A (Red) Blanket Undervoltage	109	A	V	4	A	6
01101110	B (Blue) Blanket Undervoltage	110	A	V	4	B	5
01101111	A (Red) Inline Undervoltage	111	A	V	4	A	3
01110000	B (Blue) Inline Undervoltage	112	A	V	4	B	1
01110001	A (Red) Hose Undervoltage	113	A	V	4	A	2
01110010	B (Blue) Hose Undervoltage	114	A	V	4	B	4
01110011	A (Red) Chiller Undervoltage	115	A	V	4	A	7
01110100	B (Blue) Chiller Undervoltage	116	A	V	4	B	8
01110101	A (Red) Blanket Ctrl Shutdown	117	A	T	9	C	6
01110110	B (Blue) Blanket Ctrl Shutdown	118	A	T	9	C	5
01110111	A (Red) Inline Ctrl Shutdown	119	A	T	9	C	3
01111000	B (Blue) Inline Ctrl Shutdown	120	A	T	9	C	1
01111001	A (Red) Hose Ctrl Shutdown	121	A	T	9	C	2
01111010	B (Blue) Hose Ctrl Shutdown	122	A	T	9	C	4
01111011	A (Red) Chiller Ctrl Shutdown	123	A	T	9	C	7
01111100	B (Blue) Chiller Ctrl Shutdown	124	A	T	9	C	8
01111101	A (Red) Tank Con. Cutback	125	V	W	M	C	6
01111110	B (Blue) Tank Con. Cutback	126	V	W	M	C	5
01111111	A (Red) Inline Con. Cutback	127	V	W	M	C	3
10000000	B (Blue) Inline Con. Cutback	128	V	W	M	C	1
10000001	A (Red) Hose Con. Cutback	129	V	W	M	C	2
10000010	B (Blue) Hose Con. Cutback	130	V	W	M	C	4
10000011	A (Red) Chiller Con. Cutback	131	V	W	M	C	7
10000100	B (Blue) Chiller Con. Cutback	132	V	W	M	C	8
10000101	A (Red) Tank High Fluid Temp.	133	A	T	4	A	6
10000110	B (Blue) Tank High Fluid Temp.	134	A	T	4	B	5
10000111	A (Red) Inline High Fluid Temp.	135	A	T	4	A	3
10001000	B (Blue) Inline High Fluid Temp.	136	A	T	4	B	1
10001001	A (Red) Hose High Fluid Temp.	137	A	T	4	A	2
10001010	B (Blue) Hose High Fluid Temp.	138	A	T	4	B	4
10001011	A (Red) Chiller High Fluid Temp.	139	D	T	4	A	7
10001100	B (Blue) Chiller High Fluid Temp.	140	D	T	4	B	8
10001101	A (Red) Blanket High Temp.	141	A	W	M	A	6
10001110	B (Blue) Blanket High Temp.	142	A	W	M	B	5
10001111	A (Red) Tank Low Fluid Temp.	143	D	T	1	A	6
10010000	B (Blue) Tank Low Fluid Temp.	144	D	T	1	B	5
10010001	A (Red) Inline Low Fluid Temp.	145	D	T	1	A	3
10010010	B (Blue) Inline Low Fluid Temp.	146	D	T	1	B	1
10010011	A (Red) Hose Low Fluid Temp.	147	D	T	1	A	2

Troubleshooting

Fault Code Bit Pattern (Bit 7 --> Bit 0)	Error String	Error Number	Error Code Shown on the ADM				
10010100	B (Blue) Hose Low Fluid Temp.	148	D	T	1	B	4
10010101	A (Red) Chiller Low Fluid Temp.	149	A	T	1	A	7
10010110	B (Blue) Chiller Low Fluid Temp.	150	A	T	1	B	8
10010111	No Heat A (Red) Tank	151	A	T	8	A	6
10011000	No Heat B (Blue) Tank	152	A	T	8	B	5
10011001	No Heat A (Red) Inline	153	A	T	8	A	3
10011010	No Heat B (Blue) Inline	154	A	T	8	B	1
10011011	No Heat A (Red) Hose	155	A	T	8	A	2
10011100	No Heat B (Blue) Hose	156	A	T	8	B	4
10011101	No Cooling A (Red) Chiller	157	A	T	8	A	7
10011110	No Cooling B (Blue) Chiller	158	A	T	8	B	8
10011111	A (Red) Tank RTD Fault	159	A	T	6	A	6
10100000	B (Blue) Tank RTD Fault	160	A	T	6	B	5
10100001	A (Red) Inline RTD Fault	161	A	T	6	A	3
10100010	B (Blue) Inline RTD Fault	162	A	T	6	B	1
10100011	A (Red) Hose FTS Fault	163	A	T	6	A	2
10100100	B (Blue) Hose FTS Fault	164	A	T	6	B	4
10100101	A (Red) Chiller RTD Fault	165	A	T	6	A	7
10100110	B (Blue) Chiller RTD Fault	166	A	T	6	B	8
10100111	A (Red) Blanket RTD Fault	167	A	T	6	C	6
10101000	B (Blue) Blanket RTD Fault	168	A	T	6	C	5
10101001	A (Red) Chiller RTD Fault	169	A	T	6	C	7
10101010	B (Blue) Chiller RTD Fault	170	A	T	6	C	8
10101011	A (Red) Tank Con. Fault	171	A	W	M	0	6
10101100	B (Blue) Tank Con. Fault	172	A	W	M	0	5
10101101	A (Red) Inline Con. Fault	173	A	W	M	0	3
10101110	B (Blue) Inline Con. Fault	174	A	W	M	0	1
10101111	A (Red) Hose Con. Fault	175	A	W	M	0	2
10110000	B (Blue) Hose Con. Fault	176	A	W	M	0	4
10110001	A (Red) Chiller Con. Fault	177	A	W	M	0	7
10110010	B (Blue) Chiller Con. Fault	178	A	W	M	0	8
10110011	A (Red) Tank Con. Fault	179	A	W	M	C	6
10110100	B (Blue) Tank Con. Fault	180	A	W	M	C	5
10110101	A (Red) Inline Con. Fault	181	A	W	M	C	3
10110110	B (Blue) Inline Con. Fault	182	A	W	M	C	1
10110111	A (Red) Hose Con. Fault	183	A	W	M	C	2
10111000	B (Blue) Hose Con. Fault	184	A	W	M	C	4
10111001	A (Red) Chiller Con. Fault	185	A	W	M	C	7
10111010	B (Blue) Chiller Con. Fault	186	A	W	M	C	8
10111011	High Accumulator Pressure	187	A	P	4	H	3
10111100	Low Accumulator Pressure	188	A	P	1	H	3
10111101	High Mix Head Oil Temp.	189	A	T	4	H	3
10111110	Low Mix Head Oil Level	190	A	M	B	H	3
10111111	Soft Stop Asserted	191	A	D	E	H	3
11000000	Mix Head Motor Overload	192	A	A	4	H	3
11000001	M1 Material Extend Fault	193	A	W	D	F	3
11000010	M1 Cleanout Extend Fault	194	A	W	D	D	3
11000011	M2 Material Extend Fault	195	A	W	D	F	4
11000100	M2 Cleanout Retract Fault	196	A	W	D	D	4
11000101	A (Red) Low Material Level	197	D	L	1	1	1
11000110	B (Blue) Low Material Level	198	D	L	1	2	2
11000111	A (Red) High Material Level	199	D	L	3	1	1
11001000	B (Blue) High Material Level	200	D	L	3	2	2
11001001	A (Red) Auto Refill Timeout	201	D	L	6	A	1
11001010	B (Blue) Auto Refill Timeout	202	D	L	6	B	2

Fault Code Bit Pattern (Bit 7 --> Bit 0)	Error String	Error Number	Error Code Shown on the ADM				
11001011	A (Red) Fill Sensor Fault	203	D	L	8	A	1
11001100	B (Blue) Fill Sensor Fault	204	D	L	8	B	2
11001101	A (Red) Circ. Valve Fault	205	A	W	E	R	1
11001110	B (Blue) Circ. Valve Fault	206	A	W	E	R	2
11001111	High Ratio	207	A	W	D	F	3
11010000	High Ratio	208	A	W	D	D	3
11010001	Low Ratio	209	A	W	D	F	4
11010010	Low Ratio	210	A	W	D	D	4
11010011	High Flow A (Red)	211	D	L	1	1	1
11010100	High Flow A (Red)	212	D	L	1	2	2
11010101	High Flow B (Blue)	213	D	L	3	1	1
11010110	High Flow B (Blue)	214	D	L	3	2	2
11010111	Low Flow A (Red)	215	D	L	6	A	1
11011000	Low Flow A (Red)	216	D	L	6	B	2
11011001	Low Flow B (Blue)	217	D	L	8	A	1
11011010	Low Flow B (Blue)	218	D	L	8	B	2
11011011	Low Dispense Amount	219	A	N	1	D	0
11011100	High Dispense Amount	220	A	N	4	D	0
11011101	Low Dispense Amount	221	D	N	2	D	0
11011110	High Dispense Amount	222	D	N	3	D	0
11011111	Comm. Error Motor	223	A	C	A	C	1
11100000	Comm. Error Motor	224	A	C	A	C	2
11100001	Comm. Error A (Red) Tank	225	A	C	A	C	3
11100010	Comm. Error B (Blue) Tank	226	A	C	A	C	4
11100011	Comm. Error Mix Head	227	A	C	A	C	5
11100100	Comm. Error Mix Head 2	228	A	C	A	C	6
11100101	Comm. Error Ratio Monitor	229	A	C	A	C	7
11100110	Comm. Error A (Red) Blanket	230	A	C	A	A	6
11100111	Comm. Error B (Blue) Blanket	231	A	C	A	B	5
11101000	Comm. Error A (Red) Inline	232	A	C	A	A	3
11101001	Comm. Error B (Blue) Inline	233	A	C	A	B	1
11101010	Comm. Error A (Red) Hose	234	A	C	A	A	2
11101011	Comm. Error B (Blue) Hose	235	A	C	A	B	4
11101100	Comm. Error A (Red) Chiller	236	A	C	A	A	7
11101101	Comm. Error B (Blue) Chiller	237	A	C	A	B	8
11101110	Comm. Error Field Bus	238	A	C	A	C	N
11101111	Comm. Error Discrete I/O	239	A	C	A	C	P
11110000	Comm. Error Pendant	240	A	C	A	C	R
11110001	No or Invalid Key Token	241	A	W	R	C	0
11110010	USB Logs Near Capacity	242	D	M	0	U	0
11110011	USB Update Failed	243	A	W	0	U	0
11111111	See ADM For Details	255					

Parts

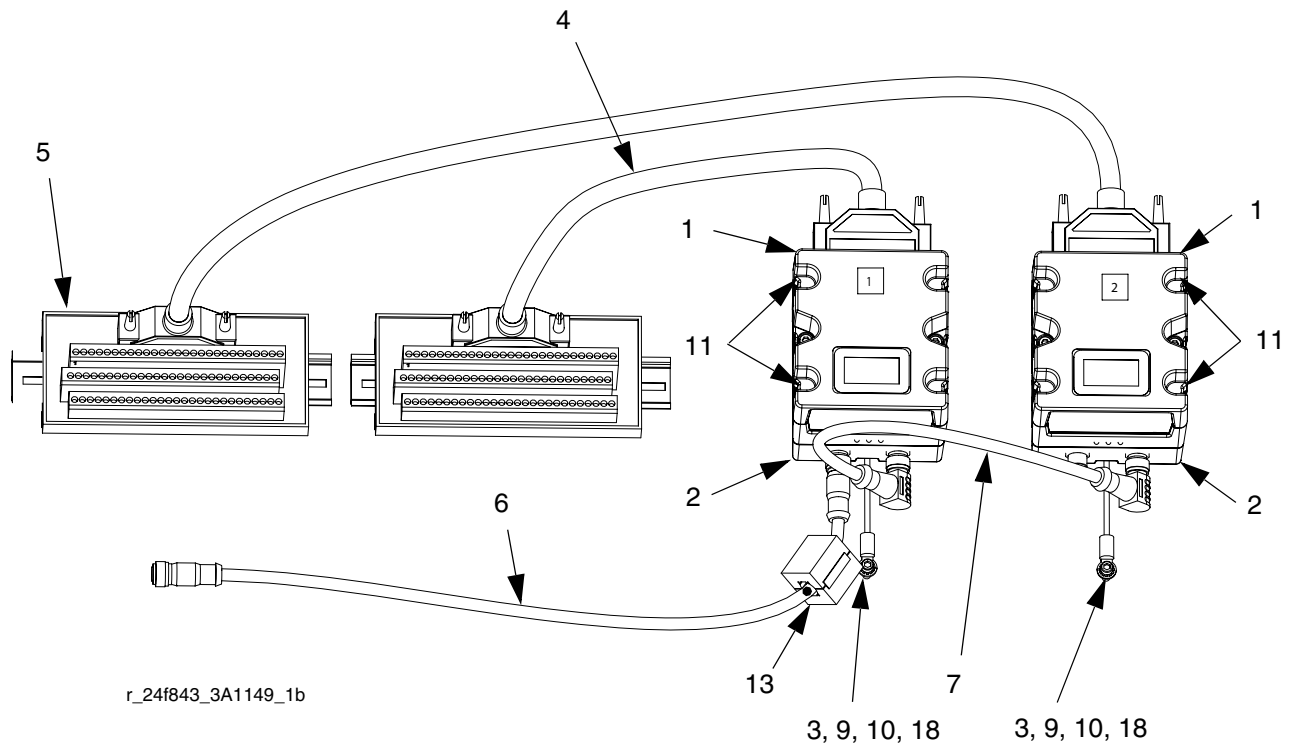

r_24f843_3A1149_1b

Ref	Part	Description	Quantity		
			24F843, Single DGM Kit	24F844, Dual DGM Kit	24G830, DGM only
1	24B681	MODULE, GCA, cube, DGM	1	2	1
2	289697	MODULE, cube, GCA, base	1	2	1
3	24C476	HARNESS, wire, ground, term, 4 in.	1	2	1
4	124638	CABLE, 78 pin, 2.5 ft, D-sub, male to female	1	2	
5	123783	BOARD, DGM, 78 pin break out	1	2	
6	121003	CABLE, CAN, female / female 3.0m	1	1	
7	123762	CABLE, CAN, 90 x 90, female / female, 0.5m		1	
9	114993	SCREW, mach, pan wash head	1	2	1
10	102063	WASHER, lock, ext	1	2	1
11	113003	SCREW, socket head cap, #10-32 x 0.62, stainless steel	5	10	5
12	277674	ENCLOSURE, cube door	1	2	1
13†	121901	SUPPRESSOR, box snap, ferrite	1	1	
17*	16H821	TOKEN, upgrade, software	*	*	*
18	100020	WASHER, lock	1	2	1

* These kits ship with software loaded. Upgrade token 16H821 is listed for reference only.

† The DGM must have a ferrite suppressor attached to the DGM end of the long CAN cable.

Accessories

Part	Description
124415	CAN Cable Extension, 9.8 ft (3.0 m)
24E898	CAN Cable Extension, 27.9 ft (8.5 m)
24E897	CAN Cable Extension, 52.5 ft (16.0 m)
24K461*	CAN Splitter, 1 male to 2 female
123792	78 pin d-sub cable; 50 ft (15.2 m), male to female
LC0032	Cable, assembly (MCM to start dispense signal)

* *Conditions Requiring a Splitter:*

- *ADM on the system is not part #289701*
- *There are no tank stands or heat zones installed.*

Technical Data

Power Requirements	9-30 VDC NEC Class 2
Weight	14 oz. (0.4 kg)
Dimensions	4.3 x 3.8 x 3.8 in. (109 x 97 x 97 mm)

Graco Standard Warranty

Graco warrants all equipment referenced in this document which is manufactured by Graco and bearing its name to be free from defects in material and workmanship on the date of sale to the original purchaser for use. With the exception of any special, extended, or limited warranty published by Graco, Graco will, for a period of twelve months from the date of sale, repair or replace any part of the equipment determined by Graco to be defective. This warranty applies only when the equipment is installed, operated and maintained in accordance with Graco's written recommendations.

This warranty does not cover, and Graco shall not be liable for general wear and tear, or any malfunction, damage or wear caused by faulty installation, misapplication, abrasion, corrosion, inadequate or improper maintenance, negligence, accident, tampering, or substitution of non-Graco component parts. Nor shall Graco be liable for malfunction, damage or wear caused by the incompatibility of Graco equipment with structures, accessories, equipment or materials not supplied by Graco, or the improper design, manufacture, installation, operation or maintenance of structures, accessories, equipment or materials not supplied by Graco.

This warranty is conditioned upon the prepaid return of the equipment claimed to be defective to an authorized Graco distributor for verification of the claimed defect. If the claimed defect is verified, Graco will repair or replace free of charge any defective parts. The equipment will be returned to the original purchaser transportation prepaid. If inspection of the equipment does not disclose any defect in material or workmanship, repairs will be made at a reasonable charge, which charges may include the costs of parts, labor, and transportation.

THIS WARRANTY IS EXCLUSIVE, AND IS IN LIEU OF ANY OTHER WARRANTIES, EXPRESS OR IMPLIED, INCLUDING BUT NOT LIMITED TO WARRANTY OF MERCHANTABILITY OR WARRANTY OF FITNESS FOR A PARTICULAR PURPOSE.

Graco's sole obligation and buyer's sole remedy for any breach of warranty shall be as set forth above. The buyer agrees that no other remedy (including, but not limited to, incidental or consequential damages for lost profits, lost sales, injury to person or property, or any other incidental or consequential loss) shall be available. Any action for breach of warranty must be brought within two (2) years of the date of sale.

GRACO MAKES NO WARRANTY, AND DISCLAIMS ALL IMPLIED WARRANTIES OF MERCHANTABILITY AND FITNESS FOR A PARTICULAR PURPOSE, IN CONNECTION WITH ACCESSORIES, EQUIPMENT, MATERIALS OR COMPONENTS SOLD BUT NOT MANUFACTURED BY GRACO. These items sold, but not manufactured by Graco (such as electric motors, switches, hose, etc.), are subject to the warranty, if any, of their manufacturer. Graco will provide purchaser with reasonable assistance in making any claim for breach of these warranties.

In no event will Graco be liable for indirect, incidental, special or consequential damages resulting from Graco supplying equipment hereunder, or the furnishing, performance, or use of any products or other goods sold hereto, whether due to a breach of contract, breach of warranty, the negligence of Graco, or otherwise.

FOR GRACO CANADA CUSTOMERS

The Parties acknowledge that they have required that the present document, as well as all documents, notices and legal proceedings entered into, given or instituted pursuant hereto or relating directly or indirectly hereto, be drawn up in English. Les parties reconnaissent avoir convenu que la rédaction du présente document sera en Anglais, ainsi que tous documents, avis et procédures judiciaires exécutés, donnés ou intentés, à la suite de ou en rapport, directement ou indirectement, avec les procédures concernées.

Graco Information

For the latest information about Graco products, visit www.graco.com.

TO PLACE AN ORDER, contact your Graco distributor or call to identify the nearest distributor.

Phone: 612-623-6921 **or Toll Free:** 1-800-328-0211 **Fax:** 612-378-3505

*All written and visual data contained in this document reflects the latest product information available at the time of publication.
Graco reserves the right to make changes at any time without notice.*

For patent information, see www.graco.com/patents.

Original instructions. This manual contains English. MM 3A1149

Graco Headquarters: Minneapolis
International Offices: Belgium, China, Japan, Korea

GRACO INC. AND SUBSIDIARIES • P.O. BOX 1441 • MINNEAPOLIS MN 55440-1441 • USA

Copyright 2010, Graco Inc. All Graco manufacturing locations are registered to ISO 9001.

www.graco.com

Revised July 2012