

# PD44

3A0987L

## Metering Valves and Feed Systems

EN

**Meter, mix, and dispense system for precise two-component micro-dispensing of sealants and adhesives. For professional use only.**

**Not approved for use in European explosive atmosphere locations.**



### Important Safety Instructions

Read all warnings and instructions in PD44 Operation-Maintenance manual 313876. Save all instructions.

See page 3 for model information, including maximum working pressure and approvals. See page 4 for product configuration information.

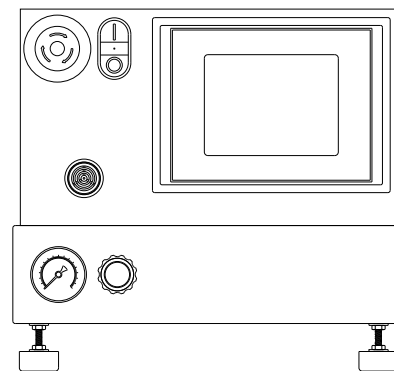

*Micrometer PD44 and  
LRT PD44 Control Box shown*

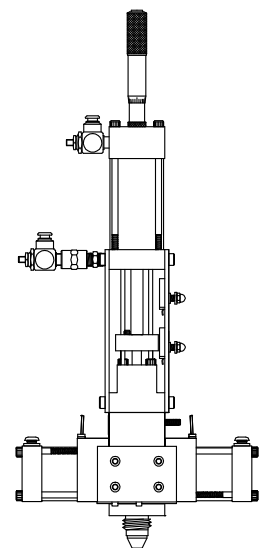

*Micrometer shown*

# Contents

**Related Manuals** ..... 2

**Models** ..... 3

**Product Configurator** ..... 4

**Accessories** ..... 9

**Parts** ..... 12

    Micrometer Drive, 02/2980-1/25 ..... 12

    Linear Resistive Transducer Drive ..... 14

    Stepper Motor Drive ..... 16

    Metering Rod and Spool Valve Cross Section . 18

    High Viscosity Spool Valve Components ..... 20

    Low Viscosity Spool Valve Components ..... 22

    Spool Air Piston Assembly ..... 24

    Material Inlet Blocks ..... 25

    1:1 Luer Nose ..... 26

    Luer Lock Nose with Check Valves ..... 27

    Standard Nose with 7/8-9 Thread ..... 28

    Nose with 7/8-9 Thread and Check Valves ... 29

    20 Oz Cartridge Feed System ..... 30

    Dyna-Mite Pump ..... 32

    5 Gallon Lid with Diaphragm Pump ..... 33

    5 Gallon Lid with 5:1 Monark Stainless Steel Pump  
    34

    5 Gallon Lid with Stainless Steel Diaphragm Pump  
    35

    5 Gallon Tank Assembly with Diaphragm Pump 36

    5 Gallon Tank Assembly with 5:1 Monark Stainless  
    Steel Pump ..... 38

    10 Gallon Tank Assemblies with Diaphragm Pump  
    40

    10 Gallon Tank Assemblies with 5:1 Monark  
    Stainless Steel Pump ..... 42

    Micrometer and LRT Logic ..... 44

    Micrometer and LRT Optional Customer Inputs 47

    Stepper Motor Driven Logic ..... 48

**Graco Standard Warranty** ..... 52

**Graco Information** ..... 52

# Related Manuals

Manuals are available at [www.graco.com](http://www.graco.com)

Component manuals in U.S. English.

PD44 Manuals	
Part	Description
313876	PD44 Metering Valves and Feed Systems Operation - Maintenance
313877	PD44 Control Box Setup - Operation
Feed System Manuals	
306565	Air-Driven, Stainless Steel Agitators
307043	Monark <sup>®</sup> Air Motor
308116	Severe-Duty, UHMWPE/PTFE or PTFE Packed Stainless Steel Pumps
308167	Low Volume Air Regulators
308168	High Volume Air Regulators
308169	Air Filters, Lubricators and Kits
309306	Air-Operated Husky <sup>™</sup> Diaphragm Pumps
312376	Stainless Steel Agitator Kit
313526	Check-Mate <sup>®</sup> Pump, Ram Packages
3A1452	Dispensit <sup>™</sup> Cartridge Retainer
308302	Dyna-Mite Pump and Ram

# Models

Metering Valve Model	Max Outlet Fluid Working Pressure psi (MPa, bar)	Max Air Working Pressure psi (MPa, bar)	Max Inlet Working Pressure psi (MPa, bar)		CE Approved*
			Metal Sleeves	Plastic Sleeves	
Linear Resistive Transducer (LRT)	2000 (14, 138)	100 (0.7, 7)	1200 (8, 83)	400 (2.8, 28)	✓
Micrometer	2000 (14, 138)	100 (0.7, 7)	1200 (8, 83)	400 (2.8, 28)	✓
Motor Driven	2000 (14, 138)	100 (0.7, 7)	1200 (8, 83)	400 (2.8, 28)	✓

\* If a custom PD44 is ordered, it will not be CE approved unless otherwise noted.

# Product Configurator

This system can be ordered with many different options as shown in the configurator below.

**PD44 C - A - BCD - EFG - H - I - J - K - L - M - NO - P - Q - RS - T - U - V - W - X**

Seal Lubricant  
 Bench Stand  
 Vacuum Pump(s)  
 Low Volume Feed Options  
 Low Volume Feed Hose  
 Low Volume Feed  
 High Volume Feed Options  
 High Volume Feed Hose  
 High Volume Feed  
 Power Cord  
 Controls  
 Mixer  
 Outlet Nose  
 Low Volume Spool  
 High Volume Spool  
 Low Volume Rod Material, Size  
 High Volume Rod Material, Size  
 Base Unit  
 Configurator Series Level

The following table applies to the PD44 configurations and indicates all of the options available for each letter shown above.

Code A	Part	Base Unit
A	964000	Micrometer PD44
B	964001	Linear Resistive Transducer PD44
C	964002	Motor Driven PD44
Code B	Part	High Volume Rod Material
<b>NOTE:</b> See code CD for last two digits of part number		
A	9641__	Hardened Steel
B	9642__	Stainless Steel, UHMW
C	9643__	Tungsten Carbide, UHMW
Code CD	Part	High Volume Rod Size
<b>NOTE:</b> See code B for first four digits of part number		
01	__01	1.25 mm rod diameter
02	__02	1.38 mm rod diameter
03	__03	1.50 mm rod diameter
04	__04	1.63 mm rod diameter
05	__05	1.75 mm rod diameter
06	__06	2.00 mm rod diameter
07	__07	2.13 mm rod diameter
08	__08	2.25 mm rod diameter
09	__09	2.38 mm rod diameter
10	__10	2.50 mm rod diameter
11	__11	2.63 mm rod diameter
12	__12	2.75 mm rod diameter
13	__13	3.00 mm rod diameter
14	__14	3.13 mm rod diameter
15	__15	3.25 mm rod diameter
16	__16	3.38 mm rod diameter
17	__17	3.50 mm rod diameter
18	__18	3.63 mm rod diameter

19	__19	3.75 mm rod diameter
20	__20	4.00 mm rod diameter
21	__21	4.25 mm rod diameter
22	__22	4.50 mm rod diameter
23	__23	4.63 mm rod diameter
24	__24	4.75 mm rod diameter
25	__25	4.88 mm rod diameter
26	__26	5.00 mm rod diameter
27	__27	5.13 mm rod diameter
28	__28	5.25 mm rod diameter
29	__29	5.50 mm rod diameter
30	__30	5.75 mm rod diameter
31	__31	6.00 mm rod diameter
32	__32	6.13 mm rod diameter
33	__33	6.25 mm rod diameter
34	__34	6.38 mm rod diameter
35	__35	6.50 mm rod diameter
36	__36	6.63 mm rod diameter
37	__37	6.75 mm rod diameter
38	__38	7.00 mm rod diameter
39	__39	7.25 mm rod diameter
40	__40	7.50 mm rod diameter
41	__41	7.63 mm rod diameter
42	__42	7.75 mm rod diameter
43	__43	7.88 mm rod diameter
44	__44	8.00 mm rod diameter
Code E	Part	Low Volume Rod Material
<b>NOTE:</b> See code FG for last two digits of part number		
A	9641__	Hardened Steel
B	9642__	Stainless Steel, UHMW
C	9643__	Tungsten Carbide, UHMW

Code FG	Part	Low Volume Rod Size
<b>NOTE:</b> See code E for first four digits of part number		
01	___01	1.25 mm rod diameter
02	___02	1.38 mm rod diameter
03	___03	1.50 mm rod diameter
04	___04	1.63 mm rod diameter
05	___05	1.75 mm rod diameter
06	___06	2.00 mm rod diameter
07	___07	2.13 mm rod diameter
08	___08	2.25 mm rod diameter
09	___09	2.38 mm rod diameter
10	___10	2.50 mm rod diameter
11	___11	2.63 mm rod diameter
12	___12	2.75 mm rod diameter
13	___13	3.00 mm rod diameter
14	___14	3.13 mm rod diameter
15	___15	3.25 mm rod diameter
16	___16	3.38 mm rod diameter
17	___17	3.50 mm rod diameter
18	___18	3.63 mm rod diameter
19	___19	3.75 mm rod diameter
20	___20	4.00 mm rod diameter
21	___21	4.25 mm rod diameter
22	___22	4.50 mm rod diameter
23	___23	4.63 mm rod diameter
24	___24	4.75 mm rod diameter
25	___25	4.88 mm rod diameter
26	___26	5.00 mm rod diameter
27	___27	5.13 mm rod diameter
28	___28	5.25 mm rod diameter
29	___29	5.50 mm rod diameter
30	___30	5.75 mm rod diameter
31	___31	6.00 mm rod diameter
32	___32	6.13 mm rod diameter
33	___33	6.25 mm rod diameter
34	___34	6.38 mm rod diameter
35	___35	6.50 mm rod diameter
36	___36	6.63 mm rod diameter
37	___37	6.75 mm rod diameter
38	___38	7.00 mm rod diameter
39	___39	7.25 mm rod diameter
40	___40	7.50 mm rod diameter
41	___41	7.63 mm rod diameter
42	___42	7.75 mm rod diameter
43	___43	7.88 mm rod diameter
44	___44	8.00 mm rod diameter

Code H	Part	High Volume Spool
1	964003	High viscosity, HS
2	964004	High viscosity, Stainless Steel/UHMWPE
3	964005	High viscosity, TC/UHMWPE
4	964006	Low viscosity, Stainless Steel
Code I	Part	Low Volume Spool
1	964011	High viscosity, HS
2	964012	High viscosity, Stainless Steel/UHMWPE
3	964013	High viscosity, TC/UHMWPE
4	964014	Low viscosity, Stainless Steel
Code J	Part	Outlet Nose
1	964020	Luer lock, equal ports, no check valves
2	964021	Luer lock, equal ports, dual check valves
3	964022	Equal ports, 7/8-9, no check valves
4	964023	Large and small ports, 7/8-9, no check valves
5	964024	Large and small ports, 7/8-9, single check valve
6	964025	Dual small ports, 7/8-9, no check valves
7	964026	Dual small ports, 7/8-9 dual check valves
Code K	Part	Mixer
1	964027	1/8-24 Luer Lock inlet and outlet, 0.5 cc
2	964028	3/16-32 bell mouth inlet, luer lock outlet, 2.0 cc
3	964029	1/4-24 bell mouth inlet, luer lock outlet, 4.0 cc
4	964030	1/4-32 bell mouth inlet, luer lock outlet, 5.5 cc
5	964031	1/4-48 bell mouth inlet, luer lock outlet, 8.0 cc
6	964032	3/16-32 bell mouth inlet, tapered outlet, 1.5 cc
7	964033	1/4-24 bell mouth inlet, tapered outlet, 3.5 cc
8	964034	3/16-24 bell mouth inlet, tapered outlet, 1.0 cc

Code L	Part	Controls
1	964035	Pneumatic, micrometer, wire harness only
2	964036	Pneumatic, micrometer, HMI controls, low level
3	964037	Pneumatic, micrometer, HMI controls, low level, I/O package
4	964038	Pneumatic, micrometer, HMI controls, low level, high level
5	964039	Pneumatic, micrometer, HMI controls, low level, high level, I/O package
6	964040	Pneumatic, linear resistive transducer, wire harness only
7	964041	Pneumatic, linear resistive transducer, HMI controls, low level
8	964042	Pneumatic, linear resistive transducer, HMI controls, low level, I/O package
9	964043	Pneumatic, linear resistive transducer, HMI controls, low level, high level
A	964044	Pneumatic, linear resistive transducer, HMI controls, low level, high level, I/O package
B	964045	Motor driven, I/O, wire harness only
C	964046	Stepper motor, HMI control, low level, high level, I/O package
Code M	Part	Power Cord
1	121055	120 VAC, North American cord set
2	121054	250 VAC, 1 phase, no plug
3	121056	10 amp, 250 volt, continental Europe
4	121057	10 amp, 250 volt, United Kingdom and Ireland
5	121058	10 amp, 250 volt, Israel
6	124864	10 amp, 250 volt, Australia
7	124861	10 amp, 250 volt, Italy
8	124863	10 amp, 250 volt, Switzerland
9	124862	10 amp, 250 volt, Denmark
A	121060	10 amp, 250 volt, India
N	--	None

Code NO	Part	High Volume Feed
01	964050	20 oz cartridge feed with mounting post
02	964051	1 gallon pail Ram and transfer pump
03	964052	5 gallon pail cover with diaphragm pump
04	964053	5 gallon pail cover diaphragm pump and agitator
05	964054	5 gallon pail cover and 5:1 transfer pump
06	964055	5 gallon pail cover, 1:1 pump with dip tube for moisture sensitive materials
07	964056	5 gallon single post Ram with 11:1 pump, mild steel
08	964057	5 gallon single post Ram with 11:1 pump, stainless steel
09	964058	5 gallon tank, support and diaphragm pump, mild steel
10	964059	5 gallon tank, support, diaphragm pump and agitator, mild steel
11	964060	5 gallon tank, support, diaphragm pump, agitator and vacuum fill, mild steel
12	964061	5 gallon tank, support, diaphragm pump, stainless steel
13	964062	5 gallon tank, support, diaphragm pump, agitator, stainless steel
14	964063	5 gallon tank, support, diaphragm pump, agitator, vacuum fill, stainless steel
15	964064	5 gallon tank, support and 5:1 pump, mild steel
16	964065	5 gallon tank, support, 5:1 pump, agitator, mild steel
17	964066	5 gallon tank, support, 5:1 pump, agitator, vacuum fill, mild steel
18	964067	5 gallon tank, support, 5:1 pump, stainless steel

19	964068	5 gallon tank, support, 5:1 pump, agitator, stainless steel
20	964069	5 gallon tank, support, 5:1 pump, agitator, vacuum fill, stainless steel
21	964070	10 gallon tank, support, diaphragm pump, mild steel
22	964071	10 gallon tank, support, diaphragm pump, agitator, mild steel
23	964072	10 gallon tank, support, diaphragm pump, agitator, vacuum fill, mild steel
24	964073	10 gallon tank, support, diaphragm pump, stainless steel
25	964074	10 gallon tank, support, diaphragm pump, agitator, stainless steel
26	964075	10 gallon tank, support, diaphragm pump, agitator, vacuum fill, stainless steel
27	964076	10 gallon tank, support, 5:1 pump, mild steel
28	964077	10 gallon tank, support, 5:1 pump, agitator, mild steel
29	964078	10 gallon tank, support, 5:1 pump, agitator, vacuum fill, mild steel
30	964079	10 gallon tank, support, 5:1 pump, stainless steel
31	964080	10 gallon, tank, support, 4:1 pump, agitator, stainless steel
32	964081	10 gallon tank, support, 5:1 pump, agitator, vacuum fill, stainless steel
NN	--	None
Code P	Part	High Volume Feed Hose
1	964082	1/2 in. x 8 ft PTFE and stainless steel hose, stainless steel fittings
3	964084	1/2 in. x 10 ft PTFE and stainless steel hose, stainless steel fittings
5	964086	1/2 in. x 15 ft PTFE and stainless steel hose, stainless steel fittings
N	--	None
Code Q	Part	High Volume Feed
A	964088	Dessicant dryers for tank lids
B	964089	Nitrogen harness assembly for tank lids
C	964090	Low level sensor 11:1 Ram only
N	--	None

Code RS	Part	Low Volume Feed
01	964050	20 oz cartridge feed with mounting post
02	964051	1 gallon pail Ram and transfer pump
03	964052	5 gallon pail cover with diaphragm pump
04	964053	5 gallon pail cover diaphragm pump and agitator
05	964054	5 gallon pail cover and 5:1 transfer pump
06	964055	5 gallon pail cover, 1:1 pump with dip tube for moisture sensitive materials
07	964056	5 gallon single post Ram with 11:1 pump, mild steel
08	964057	5 gallon single post Ram with 11:1 pump, stainless steel
09	964058	5 gallon tank, support and diaphragm pump, mild steel
10	964059	5 gallon tank, support, diaphragm pump and agitator, mild steel
11	964060	5 gallon tank, support, diaphragm pump, agitator and vacuum fill, mild steel
12	964061	5 gallon tank, support, diaphragm pump, stainless steel
13	964062	5 gallon tank, support, diaphragm pump, agitator, stainless steel
14	964063	5 gallon tank, support, diaphragm pump, agitator, vacuum fill, stainless steel
15	964064	5 gallon tank, support and 5:1 pump, mild steel
16	964065	5 gallon tank, support, 5:1 pump, agitator, mild steel
17	964066	5 gallon tank, support, 5:1 pump, agitator, vacuum fill, mild steel
18	964067	5 gallon tank, support, 5:1 pump, stainless steel

19	964068	5 gallon tank, support, 5:11 pump, agitator, stainless steel
20	964069	5 gallon tank, support, 5:1 pump, agitator, vacuum fill, stainless steel
21	964070	10 gallon tank, support, diaphragm pump, mild steel
22	964071	10 gallon tank, support, diaphragm pump, agitator, mild steel
23	964072	10 gallon tank, support, diaphragm pump, agitator, vacuum fill, mild steel
24	964073	10 gallon tank, support, diaphragm pump, stainless steel
25	964074	10 gallon tank, support, diaphragm pump, agitator, stainless steel
26	964075	10 gallon tank, support, diaphragm pump, agitator, vacuum fill, stainless steel
27	964076	10 gallon tank, support, 5:1 pump, mild steel
28	964077	10 gallon tank, support, 5:1 pump, agitator, mild steel
29	964078	10 gallon tank, support, 5:1 pump, agitator, vacuum fill, mild steel
30	964079	10 gallon tank, support, 5:1 pump, stainless steel
31	964080	10 gallon, tank, support, 4:1 pump, agitator, stainless steel
32	964081	10 gallon tank, support, 5:1 pump, agitator, vacuum fill, stainless steel
NN	--	None
<b>Code T Part Low Volume Feed Hose</b>		
1	964082	1/2 in. x 8 ft PTFE and stainless steel hose, stainless steel fittings
3	964084	1/2 in. x 10 ft PTFE and stainless steel hose, stainless steel fittings
5	964086	1/2 in. x 15 ft PTFE and stainless steel hose, stainless steel fittings
7	--	None
<b>Code U Part Low Volume Feed</b>		
A	964088	Dessicant dryers for tank lids
B	964089	Nitrogen harness assembly for tank lids
C	964090	Low level sensor 11:1 Ram only
N	--	None
<b>Code V Part Vacuum Pump(s)</b>		
1	964091	1-115V, 1 phase, 6.9 cfm, inlet and outlet filter, 1 in. hose to single tank
2	964092	1-115V, 1 phase, 6.9 cfm, inlet and outlet filter, 1 in. hose to two tanks
3	964093	1-230V, 1 phase, 6.9 cfm, inlet and outlet filter, 1 in. hose to single tank
4	964094	1-230V, 1 phase, 6.9 cfm, inlet and outlet filter, 1 in. hose to two tanks
N	--	None

<b>Code W Part Bench Stand</b>		
A	964095	Adjustable height bench stand
N	--	None
<b>Code X Part Seal Lubricant</b>		
T	206994	Fluid, TSL™, 8 ounce bottle



# Accessories

## Mixer Kits with Shroud

Part	Description
964034	Mixer, Kit, 3/16 in. (4.8mm) x 24, 10 taper tip mixers with shroud
964032	Mixer, Kit, 3/16 in. (4.8mm) x 32, 10 taper tip mixers with shroud
964028	Mixer, Kit, 3/16 in. (4.8mm) x 32, 10 Luer Lock tip mixers with shroud/sleeve
964033	Mixer, Kit, 1/4 in. (6.5mm) x 24, 10 taper tip mixers with shroud
964029	Mixer, Kit, 1/4 in. (6.5mm) x 24, 10 Luer Lock tip mixers with shroud/sleeve
964030	Mixer, Kit, 1/4 in. (6.5mm) x 32, 10 Luer Lock tip mixers with shroud/sleeve
964031	Mixer, Kit, 1/4 in. (6.5mm) x 48, 10 Luer Lock tip mixers with shroud/sleeve

## Mixer Packs

Part	Description
964027	Mixer, 1/8 in. (3.2mm) x 24 Luer Lock inlet/tip, 10 Pack
16D962	Mixer, 1/8 in. (3.2mm) x 24 Luer Lock inlet/tip, 50 Pack
16D963	Mixer, 1/8 in. (3.2mm) x 24 Luer Lock inlet/tip, 250 Pack
16D978	Mixer, 3/16 in. (4.8mm) x 24 taper tip, 50 Pack
16D979	Mixer, 3/16 in. (4.8mm) x 24 taper tip, 250 Pack
LC0077	Mixer, 3/16 in. (4.8mm) x 32 taper tip, 50 Pack
LC0084	Mixer, 3/16 in. (4.8mm) x 32 taper tip, 250 Pack
LC0082	Mixer, 3/16 in. (4.8mm) x 32 Luer Lock tip, 50 Pack
LC0090	Mixer, 3/16 in. (4.8mm) x 32 Luer Lock tip, 250 Pack
LC0078	Mixer, 1/4 in. (6.5mm) x 24 taper tip mixer, 50 Pack
LC0085	Mixer, 1/4 in. (6.5mm) x 24 taper tip mixer, 250 Pack
LC0083	Mixer, 1/4 in. (6.5mm) x 24 Luer Lock tip, 50 Pack

Part	Description
LC0089	Mixer, 1/4 in. (6.5mm) x 24 Luer Lock tip, 250 Pack
16D968	Mixer, 1/4 in. (6.5mm) x 32 Luer Lock tip, 50 Pack
16D969	Mixer, 1/4 in. (6.5mm) x 32 Luer Lock tip, 250 Pack
16D970	Mixer, 1/4 in. (6.5mm) x 48 Luer Lock tip, 50 Pack
16D973	Mixer, 1/4 in. (6.5mm) x 48 Luer Lock tip, 250 Pack

## O-Rings and Seals

For o-ring and seal locations, see the following sections:

- **Metering Rod and Spool Valve Cross Section**, beginning on page 18
- **High Viscosity Spool Valve Components**, page 20
- **Low Viscosity Spool Valve Components**, page 22

Part	Description
24E247	Kit, O-ring, chemical resistant, PD44
24E248	Kit, Seal, Spool, H.V., PD44
24E249	Kit, Seal, Spool, L.V., PD44
16B265	Seal, Posipack, 1.25, ZAP
16B266	Seal, Posipack, 1.38, ZAP
16B267	Seal, Posipack, 1.50, ZAP
16B268	Seal, Posipack, 1.63, ZAP
16B269	Seal, Posipack, 1.75, ZAP
16B270	Seal, Posipack, 2.00, ZAP
16B271	Seal, Posipack, 2.13, ZAP
16B272	Seal, Posipack, 2.25, ZAP
16B273	Seal, Posipack, 2.38, ZAP
16B274	Seal, Posipack, 2.50, ZAP
16B275	Seal, Posipack, 2.63, ZAP
16B276	Seal, Posipack, 2.75, ZAP
16B277	Seal, Posipack, 3.00, ZAP
16B278	Seal, Posipack, 3.13, ZAP
16B279	Seal, Posipack, 3.25, ZAP
16B280	Seal, Posipack, 3.38, ZAP
16B281	Seal, Posipack, 3.50, ZAP
16B282	Seal, Posipack, 3.63, ZAP
16B283	Seal, Posipack, 3.75, ZAP
16B284	Seal, Posipack, 4.00, ZAP
16B285	Seal, Posipack, 4.25, ZAP
16B286	Seal, Posipack, 4.50, ZAP
16B287	Seal, Posipack, 4.63, ZAP
16B288	Seal, Posipack, 4.75, ZAP
16B289	Seal, Posipack, 4.88, ZAP
16B290	Seal, Posipack, 5.00, ZAP
16B291	Seal, Posipack, 5.13, ZAP
16B292	Seal, Posipack, 5.25, ZAP
16B293	Seal, Posipack, 5.50, ZAP
16B294	Seal, Posipack, 5.75, ZAP
16B295	Seal, Posipack, 6.00, ZAP

Part	Description
16B296	Seal, Posipack, 6.13, ZAP
16B297	Seal, Posipack, 6.25, ZAP
16B298	Seal, Posipack, 6.38, ZAP
16B299	Seal, Posipack, 6.50, ZAP
16B300	Seal, Posipack, 6.63, ZAP
16B301	Seal, Posipack, 6.75, ZAP
16B302	Seal, Posipack, 7.00, ZAP
16B303	Seal, Posipack, 7.25, ZAP
16B304	Seal, Posipack, 7.50, ZAP
16B305	Seal, Posipack, 7.63, ZAP
16B306	Seal, Posipack, 7.75, ZAP
16B307	Seal, Posipack, 7.88, ZAP
16B450	Seal, Posipack, 8.00, ZAP

**Needles**

<b>Part</b>	<b>Description</b>
E4000025-50	Needle, Luer Lock, Sampler Package (10 each 14 ga x 1/2 in., 16 ga x 1/2 in., 18 ga x 1/2 in., 20 ga x 1/2 in., 22 ga x 1/2 in.)
E4000001-50	Needle, Luer Lock, 14 Gauge x 1/2 in., 50 Pack
E4000004-50	Needle, Luer Lock, 15 Gauge x 1/2 in., 50 Pack
E4000005-50	Needle, Luer Lock, 16 Gauge x 1 in., 50 Pack
E4000006-50	Needle, Luer Lock, 18 Gauge x 1 in., 50 Pack
E4000011-50	Needle, Luer Lock, 22 Gauge x 1/2 in., 50 Pack
E4000014-50	Needle, Luer Lock, 14 Gauge x 1 in., 50 Pack
E4000024-50	Needle, Luer Lock, 23 Gauge x 1/2 in., 50 Pack
E4000088-50	Needle, Luer Lock, 16 Gauge x 1/2 in., 50 Pack

# Parts

## Micrometer Drive, 02/2980-1/25

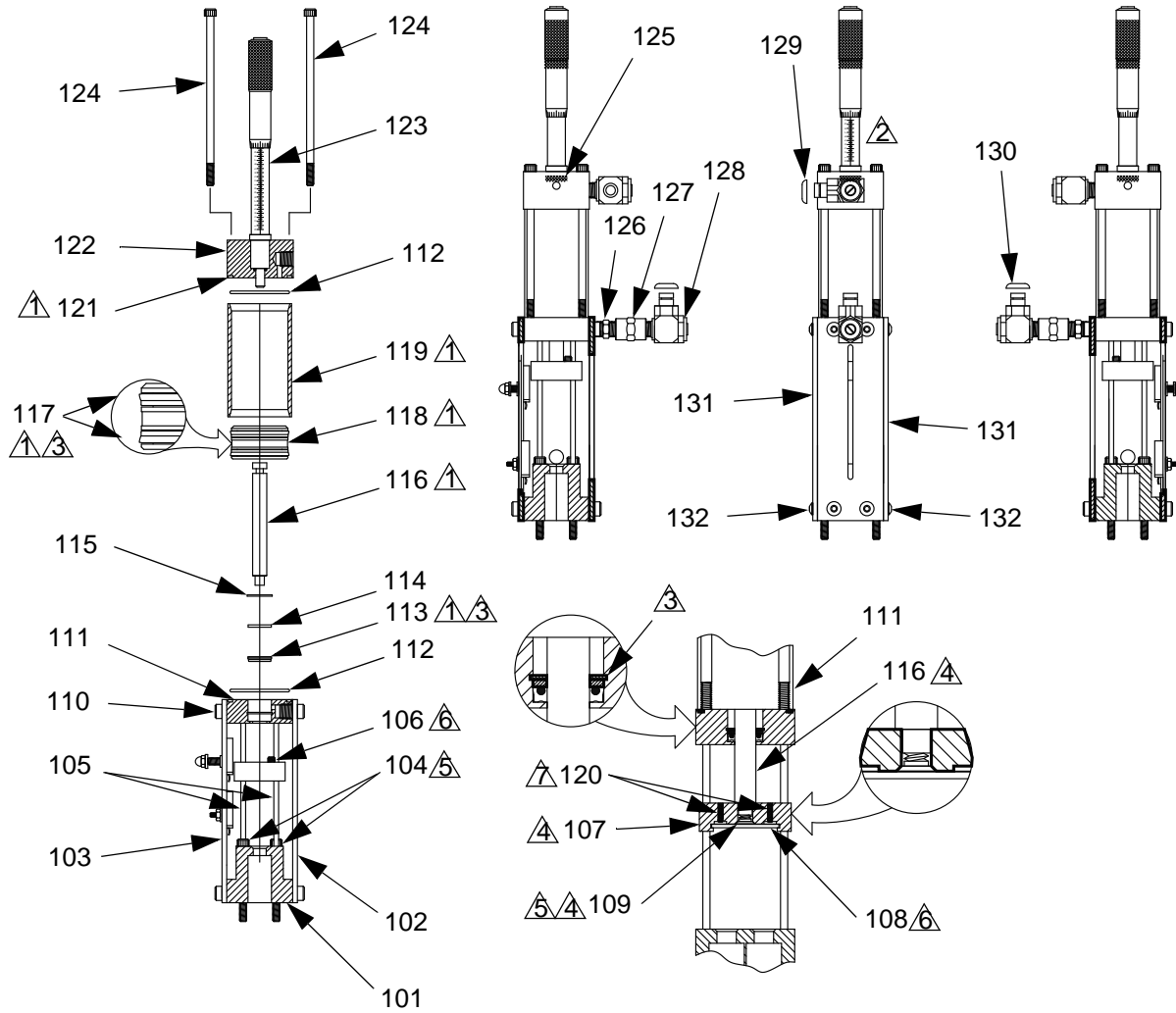

- 1 Use Krytox 203gpl on all air cylinder seals and surfaces.
- 2 Align micrometer number line with needle valve port center.
- 3 Note direction of seals on air cylinder piston and on piston rod seal.
- 4 Mount piston rod (116) to connecting block (107). Use removable thread locker Loctite #242 blue or equivalent.
- 5 Torque fastener to 67-70 in-lb (7.6-7.9 N•m).
- 6 Install spring plunger (106) and retaining plate (108) onto connecting block.
- 7 Torque fastener to 4-8 in-lb (0.45-0.90 N•m).

Ref	Part	Description	Qty
101	01/2984-2/97	BLOCK, retainer, oil cup	1
102	01/2983/97	PLATE, tie, front, 2 in.	1
103	01/2982-1/97	PLATE, plate, tie, back	1
104	96/0305/99	SCREW, socket head cap, 10-24 x 2.00, mild steel	4
105	01/2706-2.0/99	ROD, rod, guide, 1.5b x 2.0s	2
106	84/0263/11	PLUNGER, 10-32	1
107	01/2980/97	BLOCK	1
108	01/2981/99	RETAINER, rod, metering	1
109	96/0458/99	SCREW, fhsc, 10-32 x 0.50, mild steel	1
110	96/2955/98	SCREW, socket head cap, 10-24 x 0.18, stainless steel	8
111	01/2985/97	BLOCK, air cylinder	1
112*	95/0504/01	O-RING, buna, 028, 70a	2
113*	95/0849/11	SEAL, posipak, 3/8 ID x 5/8 OD	1
114	01/2704/98	WASHER, air cylinder	1
115	96/0425/99	RING, 0.625, mild steel	1
116	01/2979/97	ROD, air cylinder	1
117*	95/0601/01	SEAL, u-cup, 1-3/16 ID x 1-1/2 OD	2
118	01/2702/97	PISTON, air cylinder, rod, 1.5b x 2.0s	1
119	01/2701-2.0/97	TUBE, air cylinder, aluminum	1
120	96/0608/99	SCREW, shs, 6-32 x 0.31, cup point, mild steel	2
121*	95/0900/00	O-RING, fluoroelastomer, 009, 75a	1
122†	01/2969/97	CAP, top, air cylinder, rod	1
123†	---	TOOL, micrometer, 0-2 in.	1
124	96/0098-45/99	SCREW, shc, 10-24 x 4.50, mild steel	4
125†	96/0523/99	SCREW, shs, 1/4-20 x 0.38, cone point, mild steel	2
126	94/0525/96	FITTING, nipple, hex, 1/8 npt, brass	1
127	94/0767/96	COUPLING, hex, 1/8 npt, brass	1
128	123541	VALVE, needle, 1/8 npt x 1/4 t, press-to-fit	2
129	123540	BUTTON, snap-on, 1/4 tube, red	1
130	123539	BUTTON, snap-on, 1/4 tube, blue	1
131	01/2995/11	GUARD, guard, side	2
132	96/0271/99	FASTENER, bhcs, 8-32 x 0.31, mild steel	6

\* Parts included in Kit 95/2980-1/25 (purchase separately).

† Parts included in assembly 24K620 (purchase separately).

--- Parts not available for individual sale.

# Linear Resistive Transducer Drive

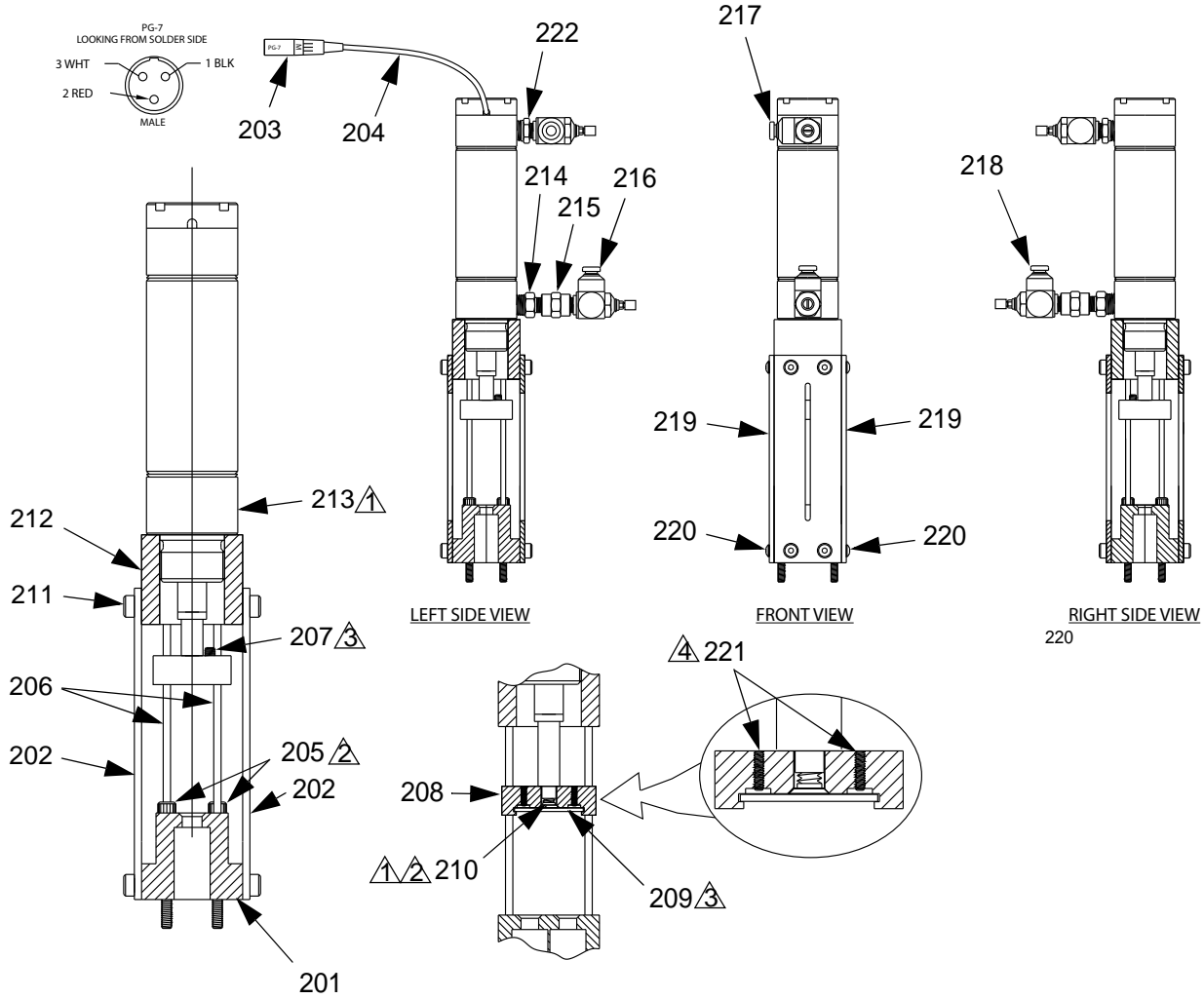

- 1 Use removable thread locker Loctite #242 blue or equal on fastener (210) and cylinder (213).
- 2 Torque fastener to 67-70 in-lb (7.6-7.9 N•m).
- 3 Install spring plunger (207) and retaining plate (209) onto connecting block.
- 4 Torque fastener to 4-8 in-lb (0.45-0.90 N•m).

Ref	Part	Description	Qty
201	01/2984-2/97	BLOCK, retainer, oil cup	1
202	01/2983/97	PLATE, tie, front, 2 in.	2
203	81/0360-3M/11	CONNECTOR, plug, male, 3-pin, RTD	1
204	61/0086/11	JACKET, shrink, 1/8, black, semi-rigid	0.5
205	96/0305/99	SCREW, shc, 10-24 x 2.00, mild steel	4
206	01/2706-2.0/99	ROD, rod, guide, 1.5b x 2.0s	2
207	84/0263/11	PLUNGER, 10-32	1
208	01/2980/97	BLOCK	1
209	01/2981/99	RETAINER, rod, metering	1
210	96/0458/99	SCREW, fhsc, 10-32 x 0.50, mild steel	1
211	96/2955/98	SCREW, shc, shdr, 0.25, 10-24 x 0.18, stainless steel	8
212	01/2985-1/97	BLOCK, air cylinder, lvdt	1
213	83/0070-2PD/11	CYLINDER, 1.5b x 2.0s, special tip	1
214	94/0499/96	ADAPTER, hex, 1/4 npt x 1/8 npt, male x male, brass	1
215	94/0767/96	COUPLING, hex, 1/8 npt, brass	1
216	123541	VALVE, needle, 1/8 npt x 1/4 t, press-to-fit	2
217	123540	BUTTON, snap-on, 1/4 tube, red	1
218	123539	BUTTON, snap-on, 1/4 tube, blue	1
219	01/2995/11	GUARD, guard, side	2
220	96/0271/99	FASTENER, bhcs, 8-32 x 0.31, mild steel	6
221	96/0608/99	SCREW, shs, 6-32x0.31, cup pt, mild steel	2
222	94/0598/96	BUSHING, 1/4npt x 1/8npt, brass	1

# Stepper Motor Drive

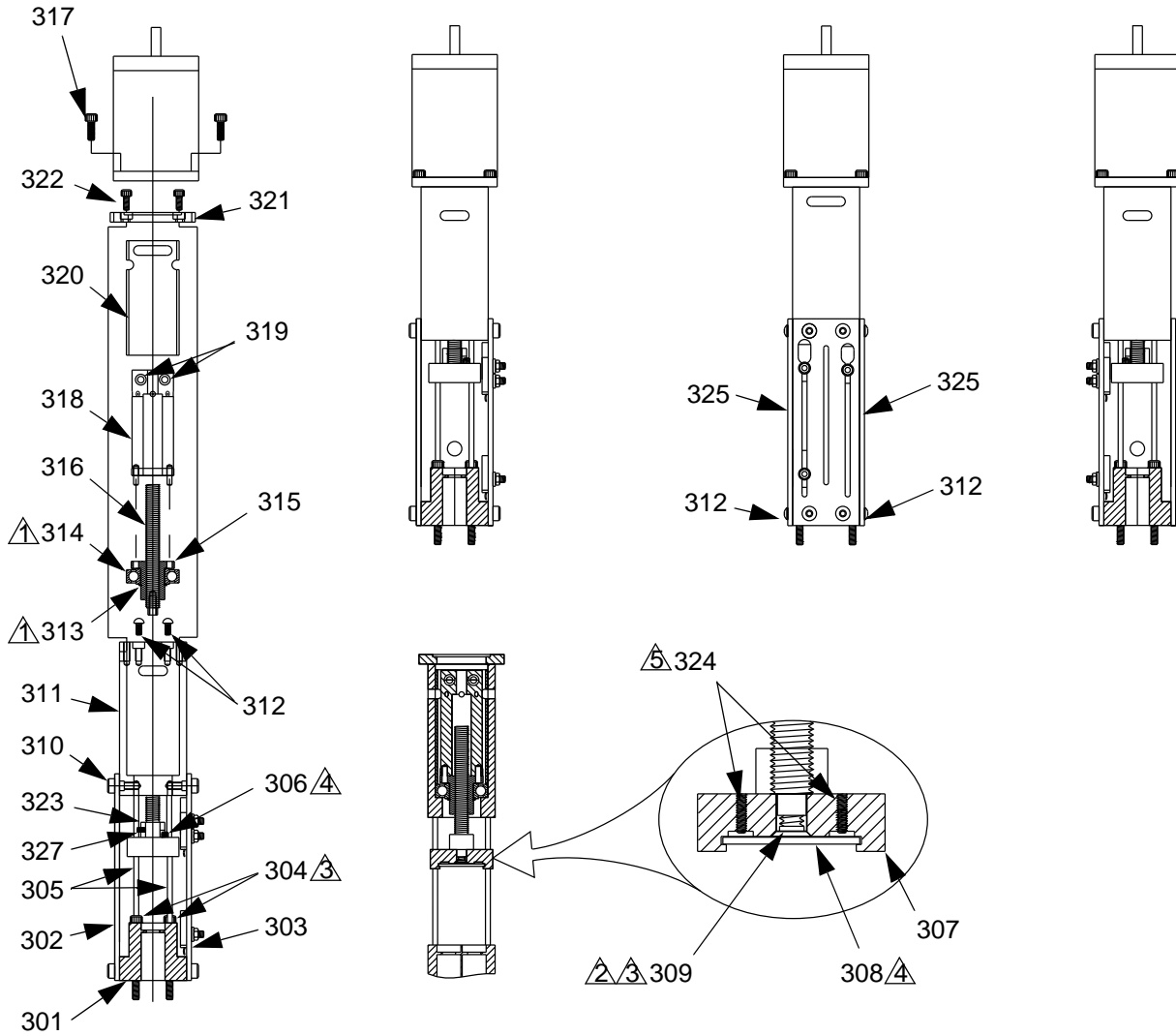

- ① Press bearing (314) onto lead screw drive nut (315). Secure with retaining ring (313).
- ② Use removable thread locker Loctite #242 blue or equal on fastener (309).
- ③ Torque fastener to 67-70 in-lb (7.6-7.9 N•m).
- ④ Install spring plunger (306) and retaining plate (308) onto connecting block.
- ⑤ Torque fastener to 4-8 in-lb (0.45-0.90 N•m).



Ref	Part	Description	Qty
301	01/2984-2/97	BLOCK, retainer, oil cup, 1.5b	1
302	01/2983/97	PLATE, tie, front, 2 in.	1
303	01/2982-1/97	PLATE, plate, tie, back	1
304	96/0305/99	SCREW, shc, 10-24 x 2.00, mild steel	4
305	01/2706-2.0/99	ROD, rod, guide, 1.5b x 2.0s	2
306	84/0263/11	PLUNGER, 10-32	1
307	01/2980/97	BLOCK	1
308	01/2981/99	RETAINER, rod, metering, pd3	1
309	96/0458/99	SCREW, fhsc, 10-32 x 0.50, mild steel	1
310	96/2955/98	SCREW, shc, 0.25, 10-24 x 0.18, stainless steel	8
311	01/2990/97	HOUSING, lead screw	1
312	96/0271/99	FASTENER, bhcs, 8-32 x 0.31, mild steel	8
313	96/0209/99	RING, 0.625, mild steel	1
314	84/0129/11	BALL, 0.62ID x 1.375 OD	1
315	01/2993/25	NUT, lead screw, drive	1
316	01/2994/25	SCREW, lead screw, drive	1
317	96/0323/99	SCREW, shc, 10-32 x 0.50, mild steel	4
318	01/2991-1/97	COUPLER, lead screw, 1/4	1
319	96/0363/99	SCREW, shc, 6-32 x 0.38, mild steel	2
320	01/2992/97	RETAINER, bearing, leadscrew	1
321	01/2890/97	PLATE	1
322	96/0187/98	SCREW, shc, 8-32 x 0.38, stainless steel	4
323	01/2993-S/89	SPACER, drive nut	1
324	96/0608/99	SCREW, shs, 6-32 x 0.31, cup point, mild steel	2
325	01/2995/11	GUARD, guard, side	2
327	B3000061	SCREW, shs, 6-32 x 0.25, nylon point, stainless steel	1

# Metering Rod and Spool Valve Cross Section

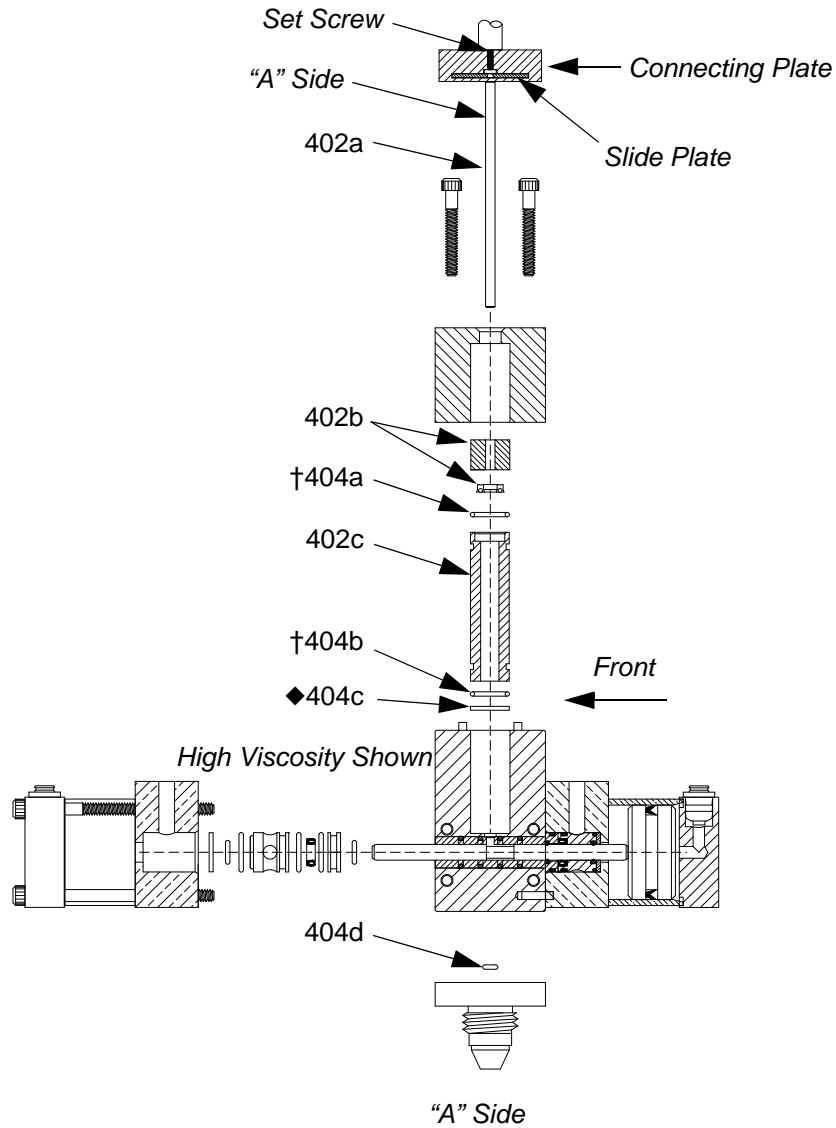

† O-ring

◆ PTFE Gasket

**NOTE:** Other parts of valve that are not included in this assembly are shown for reference only.

**NOTE:** See the rebuild procedure in the PD44 Metering Valves and Feed Systems Operation and Maintenance manual. See **Related Manuals** on page 2.

## Rod Assembly Kits

Reference					
402 †				404 ◆	
Description	Hardened Steel Rod Assembly Kit	Stainless Steel Rod Assembly Kit	Tungsten Carbide Rod Assembly Kit	Description	Part
KIT, rod, 1.25	964101	964201	964301	KIT, o-ring	24E247
KIT, rod, 1.38	964102	964202	964302		
KIT, rod, 1.50	964103	964203	964303		
KIT, rod, 1.63	964104	964204	964304		
KIT, rod, 1.75	964105	964205	964305		
KIT, rod, 2.00	964106	964206	964306		
KIT, rod, 2.13	964107	964207	964307		
KIT, rod, 2.25	964108	964208	964308		
KIT, rod, 2.38	964109	964209	964309		
KIT, rod, 2.50	964110	964210	964310		
KIT, rod, 2.63	964111	964211	964311		
KIT, rod, 2.75	964112	964212	964312		
KIT, rod, 3.00	964113	964213	964313		
KIT, rod, 3.13	964114	964214	964314		
KIT, rod, 3.25	964115	964215	964315		
KIT, rod, 3.38	964116	964216	964316		
KIT, rod, 3.50	964117	964217	964317		
KIT, rod, 3.63	964118	964218	964318		
KIT, rod, 3.75	964119	964219	964319		
KIT, rod, 4.00	964120	964220	964320		
KIT, rod, 4.25	964121	964221	964321		
KIT, rod, 4.50	964122	964222	964322		
KIT, rod, 4.63	964123	964223	964323		
KIT, rod, 4.75	964124	964224	964324		
KIT, rod, 4.88	964125	964225	964325		
KIT, rod, 5.00	964126	964226	964326		
KIT, rod, 5.13	964127	964227	964327		
KIT, rod, 5.25	964128	964228	964328		
KIT, rod, 5.50	964129	964229	964329		
KIT, rod, 5.75	964130	964230	964330		
KIT, rod, 6.00	964131	964231	964331		
KIT, rod, 6.13	964132	964232	964332		
KIT, rod, 6.25	964133	964233	964333		
KIT, rod, 6.38	964134	964234	964334		
KIT, rod, 6.50	964135	964235	964335		
KIT, rod, 6.63	964136	964236	964336		
KIT, rod, 6.75	964137	964237	964337		
KIT, rod, 7.00	964138	964238	964338		
KIT, rod, 7.25	964139	964239	964339		
KIT, rod, 7.50	964140	964240	964340		
KIT, rod, 7.63	964141	964241	964341		
KIT, rod, 7.75	964142	964242	964342		
KIT, rod, 7.88	964143	964243	964343		
KIT, rod, 8.00	964144	964244	964344		

† Seals are available separately. See **O-Rings and Seals** section on page 10.

◆ One kit is required for each side of the valve A and B.

# High Viscosity Spool Valve Components

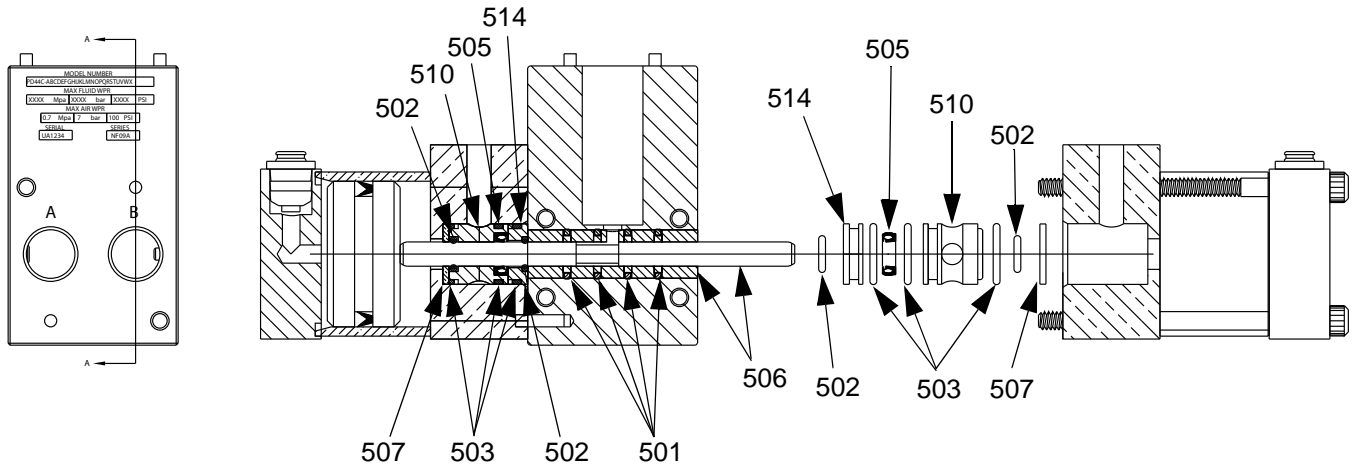

**NOTE:** See the rebuild procedure in the PD44 Metering Valves and Feed Systems Operation and Maintenance manual. See **Related Manuals** on page 2.

Ref	Part	Description	Quantity †					
			Spool Valve, A Side, HS	Spool Valve, A Side, SS	Spool Valve, A Side, TC	Spool Valve, B Side, HS	Spool Valve, B Side, SS	Spool Valve, B Side, TC
501★		RING, quad	4	4	4	4	4	4
502★		O-RING	4	4	4	4	4	4
503★		O-RING	6	6	6	6	6	6
505★		SEAL	2	2	2	2	2	2
506◆	U50205	VALVE, spool, HS, A Side	1					
	24E565	VALVE, spool, SS, A Side		1				
	24E579	VALVE, spool, TC, A Side			1			
	U50206	VALVE, spool, HS, B Side				1		
	24E566	VALVE, spool, SS, B Side					1	
	24E567	VALVE, spool, TC, B Side						1
507	01/2975-4/98	WASHER, seal, high viscosity	2	2	2	2	2	2
510	01/2974-5/70	CARTRIDGE, high viscosity, 1.5b	2	2	2	2	2	2
514	01/2989/98	RETAINER, seal, spool, high viscosity	2	2	2	2	2	2

† Quantities listed are for one side of the valve.

★ O-rings and seals are contained in kit 24E248. 1 kit is required for each side of the valve.

◆ HS = hardened steel, SS = stainless steel, TC = Tungsten Carbide/UHMW.  
Spools are handed: A-Side, B-Side.

# Low Viscosity Spool Valve Components

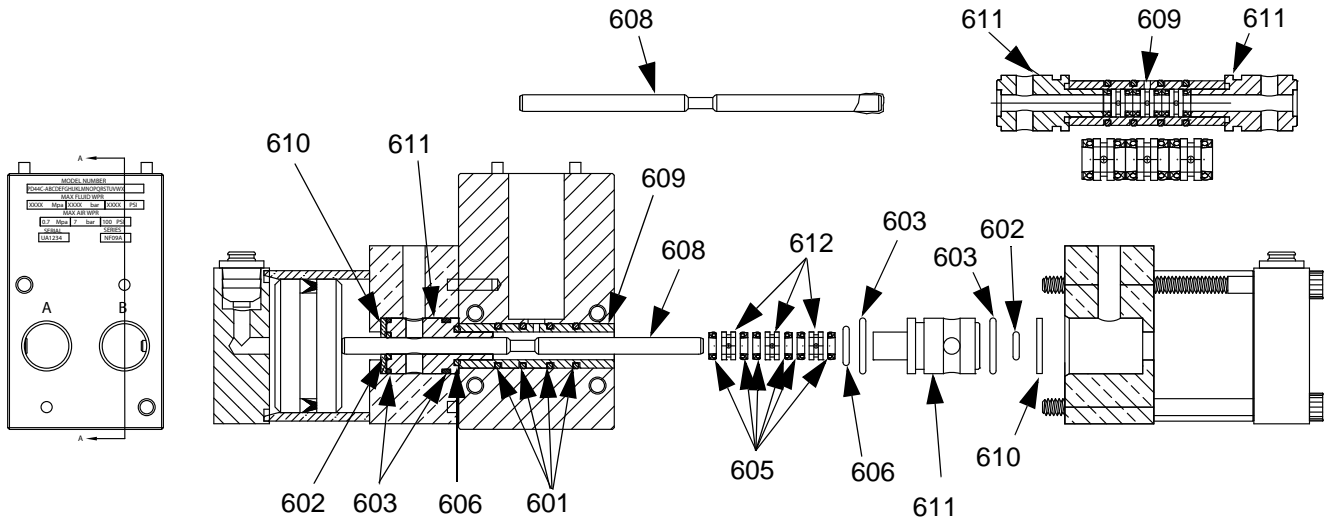

**NOTE:** See the rebuild procedure in the PD44 Metering Valves and Feed Systems Operation and Maintenance manual. See **Related Manuals** on page 2.

Ref	Part	Description	Quantity †	
			Spool Valve, Low Viscosity, A Side	Spool Valve, Low Viscosity, B Side
601★		RING, quad	4	4
602★		O-RING	2	2
603★		O-RING	4	4
605★		SEAL	6	6
606★		O-RING	2	2
608	01/2960/98	SPOOL, low viscosity	1	1
609◆	01/2961/98	SLEEVE, low viscosity, A side, stainless steel, quad	1	
	01/2962/98	SLEEVE, low viscosity, B side, stainless steel, quad		1
610	01/2975-3/98	WASHER, seal, low viscosity	2	2
611	01/2977/70	CAP, end, seal, low viscosity	2	2
612	01/2963/98	SPACER, seal, low viscosity	3	3

† Quantities listed are for one side of the valve.

★ O-rings and seals are contained in kit 24E249. 1 kit is required for each side of the valve.

◆ Sleeves are handed: A-Side, B-Side.

# Spool Air Piston Assembly

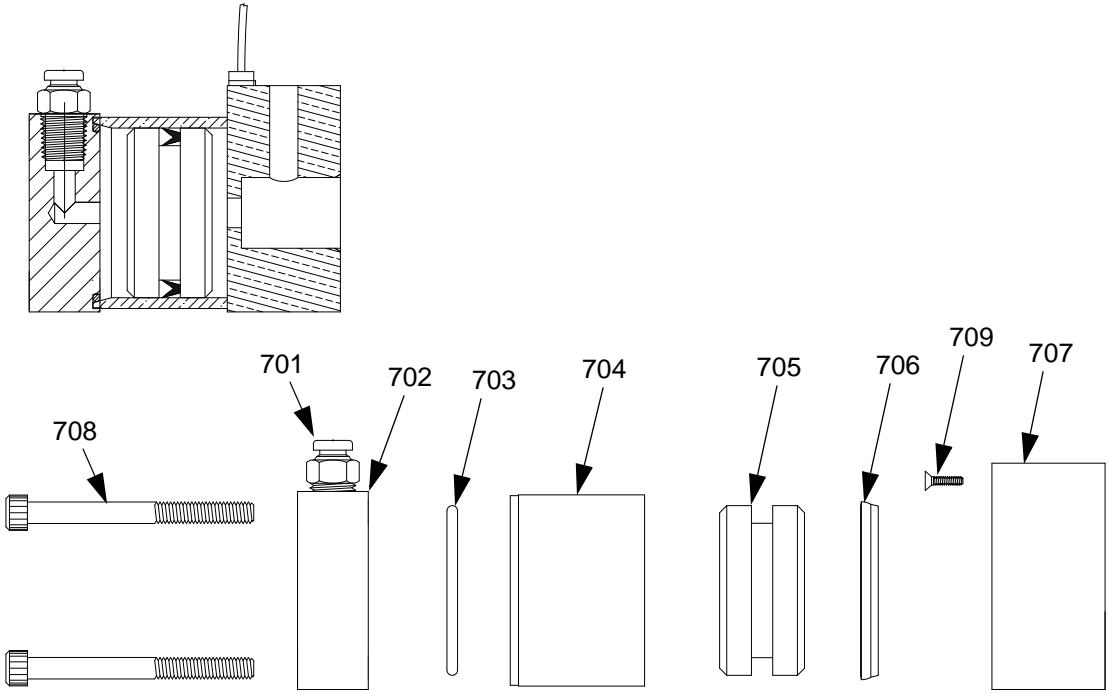

Apply thin coat of krytox 203GPL to inner diameter of cylinder wall (704).

Use krytox 203GPL on all o-ring and seal surfaces.

Ref	Part	Description	Qty
701	123453	FITTING, 1/4 tube x 1/8 npt, male	1
702	16A565	CAP, end, air cylinder, spool	1
703	95/0504/01	O-RING, buna, 028, 70a	1
704	01/2973/97	CYLINDER, cylinder, air, spool, 1.5	1
705	01/2976/97	PISTON, air cylinder, spool, 1.5b	1
706	95/0601/01	SEAL, u-cup, 1-3/16 ID x 1-1/2 OD, nitrile	1
707	01/2971-1/97	BLOCK, seal, air cylinder, spool	1
708	96/0305/99	SCREW, shc, 10-24 x 2.00, mild steel	2
709	104702	SCREW, cap, socket head	1



# Material Inlet Blocks

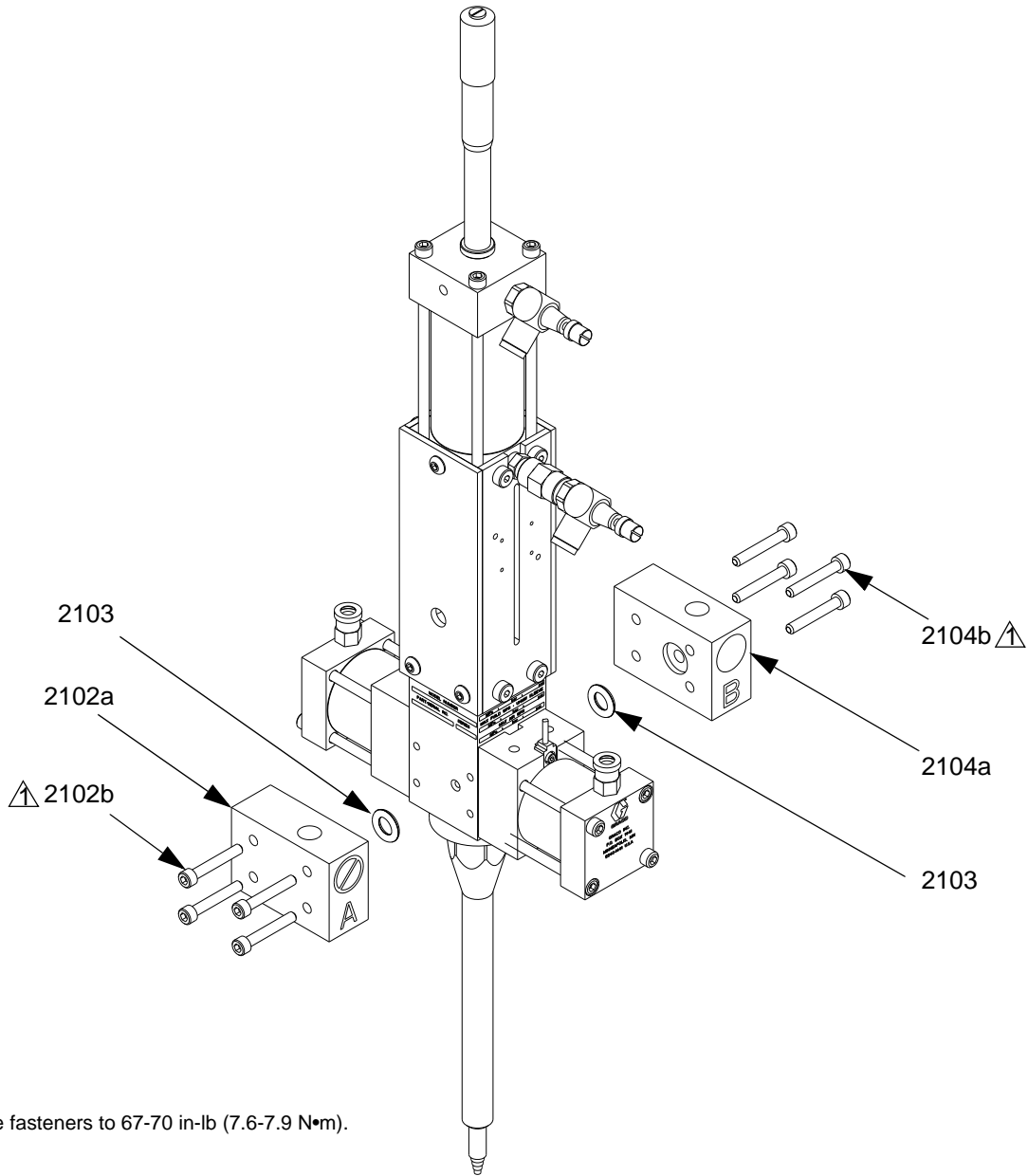

 Torque fasteners to 67-70 in-lb (7.6-7.9 N•m).

Ref	Part	Description	Qty
2102	02/2995-S/25	KIT, inlet, PD44, top, 1/4 NPT, LH, SS	1
.2102a	16A570	BLOCK, PD44, top inlet, 1/4 NPT, SS	1
.2102b	96/0097/99	SCREW, socket head, #10-24x1.25, MS	4
2103★	24E247	KIT, o-ring, FX75, PD44	1
2104	02/2996-S/25	KIT, inlet, PD44, top, 1/4 NPT, RH, SS	1
.2104a	16A571	BLOCK, PD44, top inlet, 1/4 NPT, SS	1
.2104b	96/0097/99	SCREW, socket head, #10-24x1.25, MS	4

★ Kit includes additional o-rings. See **Metering Rod and Spool Valve Cross Section** beginning on page 18, item 404.

## 1:1 Luer Nose

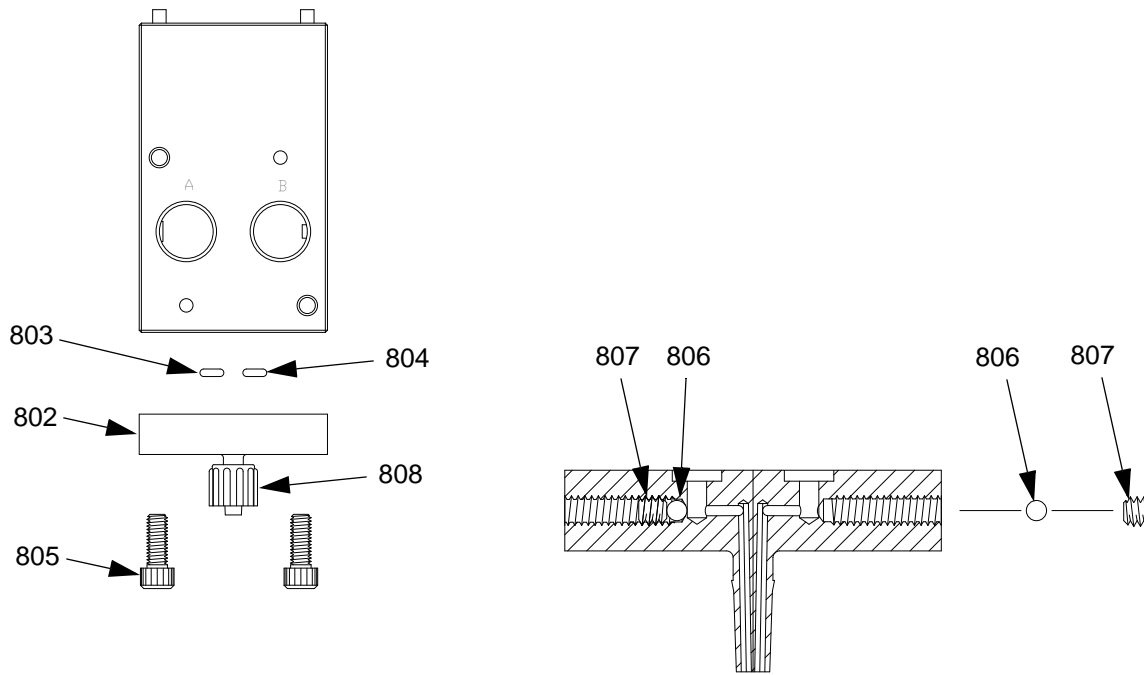

Ref	Part	Description	Qty
802	01/2725/98	BLOCK, nose, body, 1.5b x 1:1	1
805	96/0125/99	SCREW, shc, 10-24 x 0.50, mild steel	2
806	94/3108/70	BALL, ball, 0.094 dia, acetal	2
807	96/0510/99	SCREW, shs, 6-32 x 0.13, flat point, mild steel	2
808	94/0645/89	RING, lock, nylon	1

# Luer Lock Nose with Check Valves

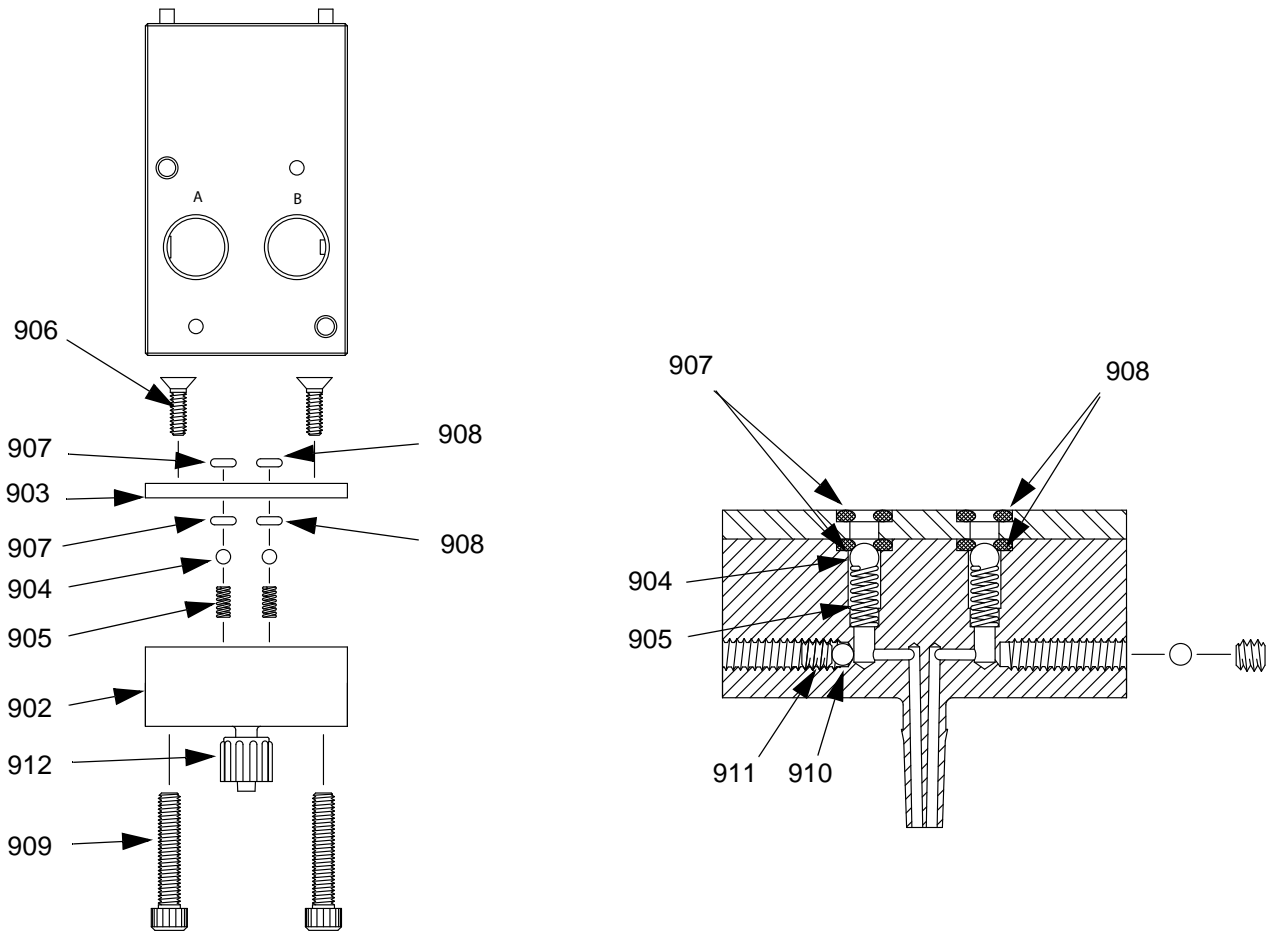

Ref	Part	Description	Qty
902	01/2734/98	BLOCK, 1.5b, 1:1, a/b	1
903	01/2728/98	PLATE, retaining, nose, 1.5b, 1:1, stainless steel	1
904	94/3110/70	BALL, ball, 0.125 dia, acetal	2
905	97/0203/98	SPRING, compression, 0.120 OD x 0.3125l, 7.41l	2
906	96/0119/99	SCREW, fhsc, 6-32 x 0.50, mild steel	2
907★		O-RING	2
908★		O-RING	2
909	96/0307-1/99	SCREW, shc, 10-24 x 1.00, mild steel	2
910	94/3108/70	BALL, ball, 0.094 dia, acetal	2
911	96/0510/99	SCREW, shs, 6-32 x 0.13, flat point, mild steel	2
912	94/0645/89	RING, lock, nylon	1

★ O-rings are available in kit 24E247. See **Metering Rod and Spool Valve Cross Section** beginning on page 18.

## Standard Nose with 7/8-9 Thread

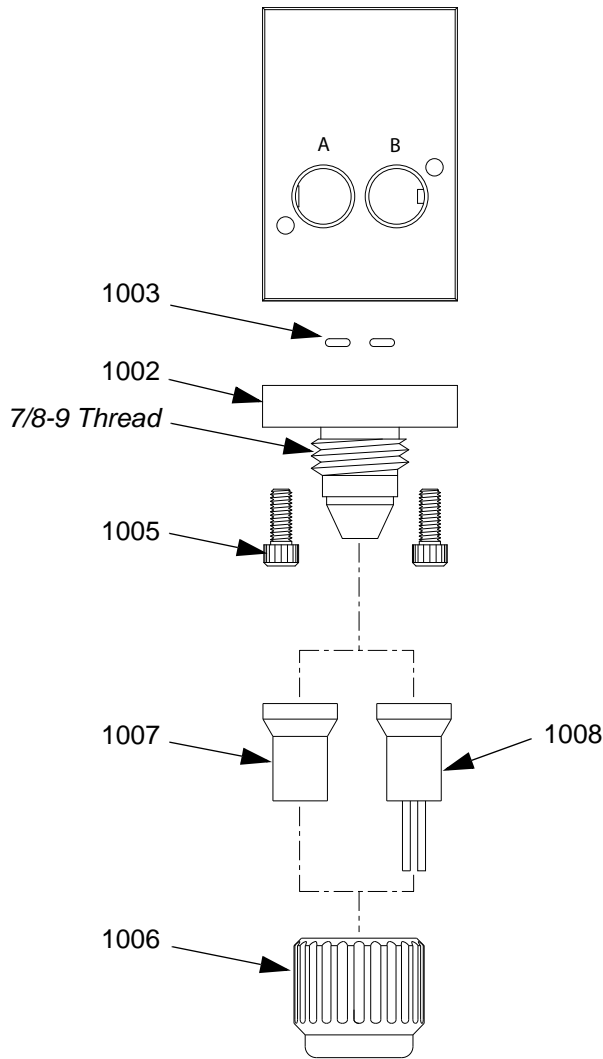

Ref	Part	Description	Quantity	
			Large Port A, Large Port B	Large Port A, Small Port B
1002	01/2726/98	BLOCK, nose		1
	01/2723/98	BLOCK, nose	1	
1003★		O-RING	2	2
1005	96/0125/99	SCREW, shc, 10-24 x 0.50, mild steel	2	2
1006	60/0137/89	NUT, retaining, 3/16", 1/4", & 3/8"	1	1
1007	01/2828/87	NOZZLE, ratio check, PD, 1.5, plug	1	1
1008	01/2825-2/87	NOZZLE, ratio check, PD, 1.5B, H1/Low	1	
	01/2825/87	NOZZLE, ratio check, PD, 1.5B notes		1

★ O-rings are available in kit 24E247. See **Metering Rod and Spool Valve Cross Section** beginning on page 18.

## Nose with 7/8-9 Thread and Check Valves

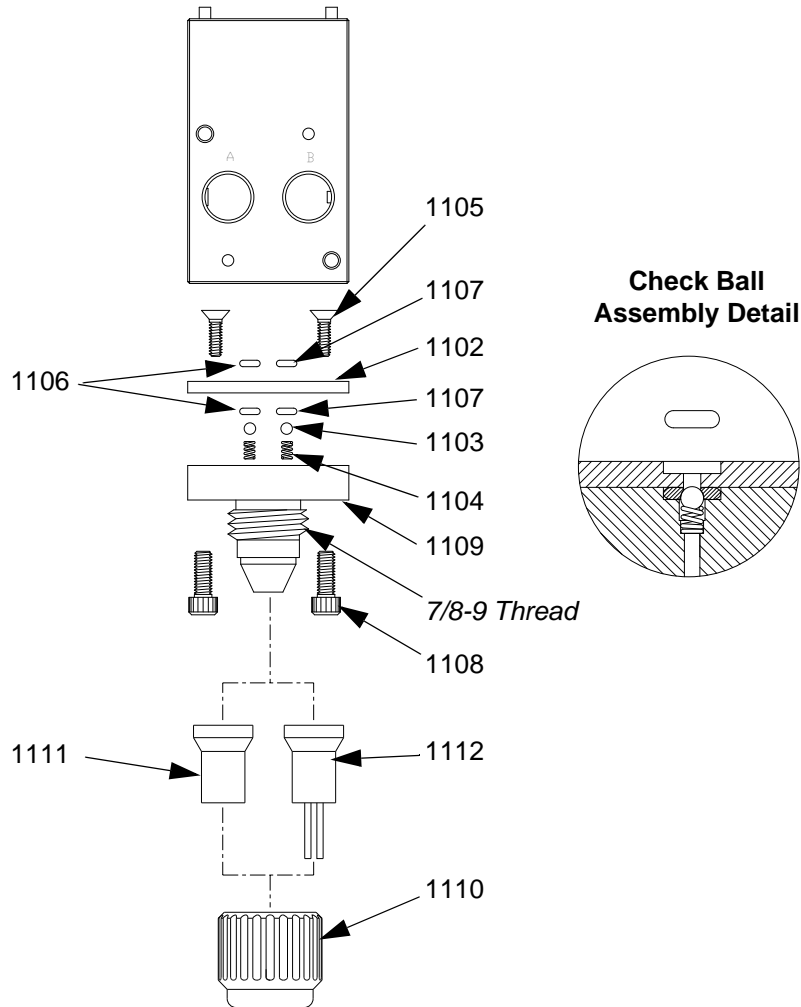

Ref	Part	Description	Quantity	
			Small Ports, Dual Check	Small Ports, No Check
1102	01/2728/98	PLATE, retaining, nose, 1.5b, 1:1, stainless steel	1	
1103	94/3110/70	BALL, ball, 0.125 dia, acetal	2	
1104	97/0203/98	SPRING, compression, 0.120 od x 0.3125l, 7.41l	2	
1105	96/0119/99	SCREW, fhsc, 6-32 x 0.50, mild steel	2	
1106★		O-RING	2	2
1107★		O-RING	2	2
1108	96/0125/99	SCREW, shc, 10-24 x 0.50, mild steel	2	2
1109	01/2727/98	NOSE	1	1
1110	60/0137/89	NUT, retaining, 3/16", 1/4", & 3/8"	1	1
1111	01/2828/87	NOZZLE, ratio check, PD, 1.5, plug	1	1
1112	01/2825-1/87	NOZZLE, ratio check, PD, 1.53, low	1	1

★ O-rings are available in kit 24E247. See **Metering Rod and Spool Valve Cross Section** beginning on page 18.

# 20 Oz Cartridge Feed System

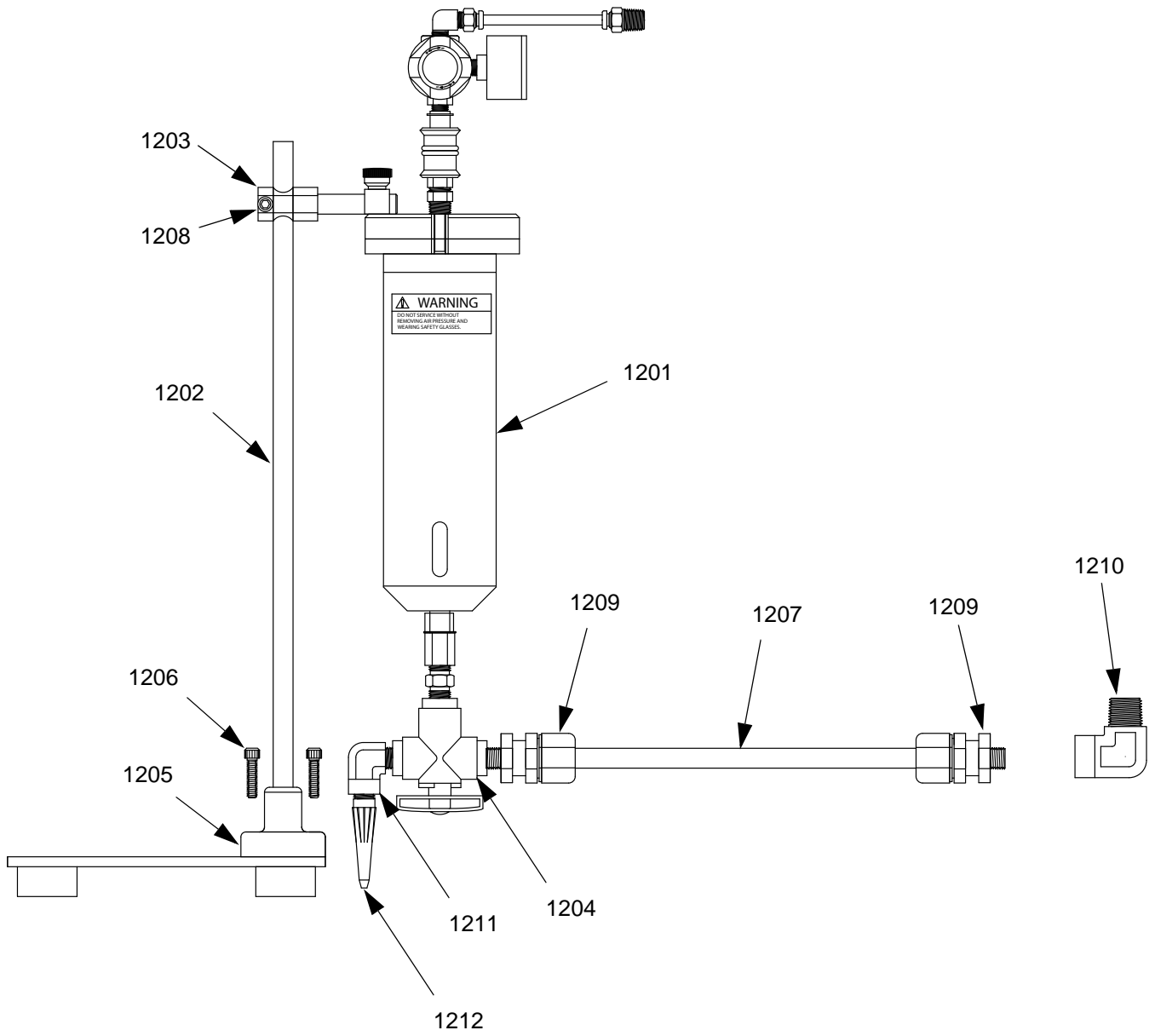

Ref	Part	Description	Qty
1201	24H683	CARTRIDGE, 20 oz retainer	1
1202	A8000004	POST, mounting, 1/2 x 24	1
1203	A8000006	CLAMP, 8040, bracket	1
1204	G0100091	VALVE, ball, 3w, 1/4 npt, female, plastic	1
1205	A8000088	BASE, base, round, for 1/2 rod	1
1206	96/0031/99	FASTENER, shc, 1/4-20 x 1.00, mild steel	2
1207	V-5384K565	TUBE, 0.375 ID x 0.500 OD, polyethylene	2
1208	96/0030/99	SCREW, shc, 1/4-20 x 0.75, mild steel	1
1209	94/0661/85	CONNECTOR, 1/2 tube x 1/4 npt, male	2
1210	94/0300-1/98	FITTING, elbow, straight, 90, 1/4 npt, male/female, stainless steel	2
1211	94/0320-1/98	FITTING, nipple, hex, 1/4 npt, male/male, stainless steel, 5k, 3	1
1212	94/0553-2/85	FITTING, nozzle, 1/4 npt, male, x 1/8 ID x 2 in.	1

# Dyna-Mite Pump

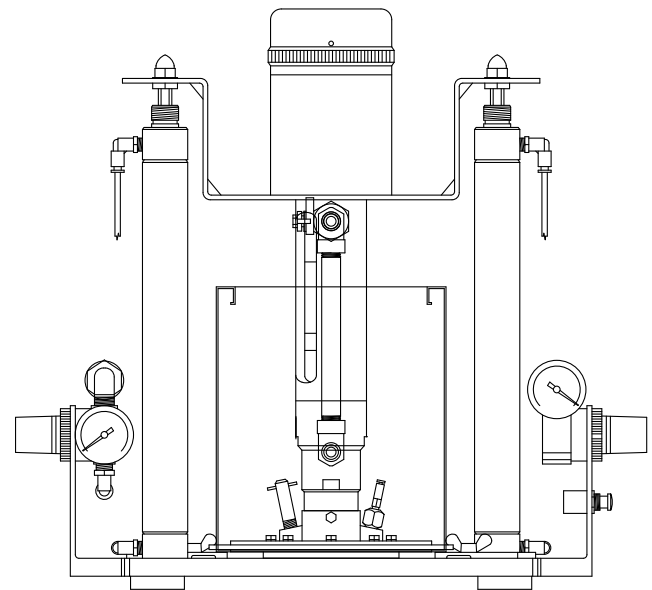
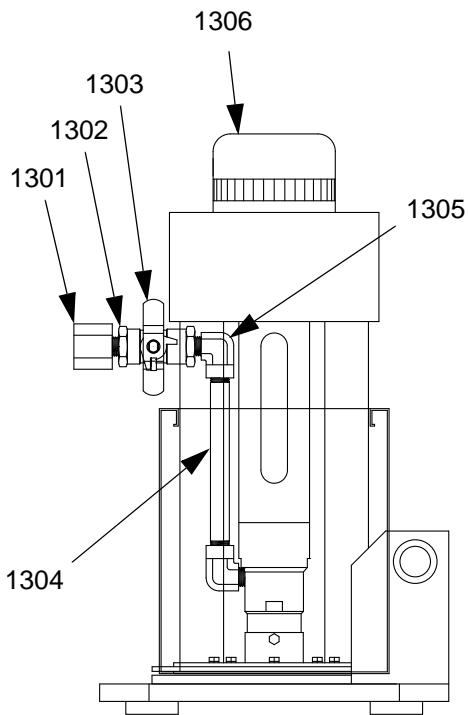
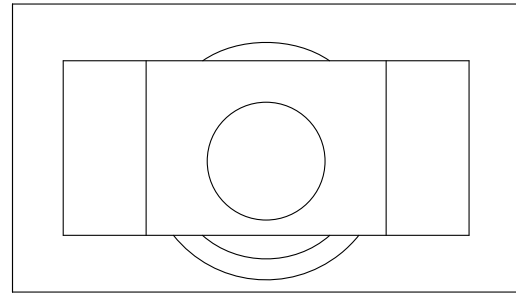

Ref	Part	Description	Qty
1301	94/0385/98	FITTING, reducer, 1/2 npt x 1/4 npt, female/male, stainless steel	1
1302	94/0900-R2/98	VALVE, ball, 2w, 1/4 npt, female, 2000 psi	1
1303	94/0898-R2/98	HANDLE, butterfly, 1/4 thru 1/2	1
1304	94/0073/98	FITTING, nipple, 1/4 npt x 5.00, male/male, stainless steel	1
1305	94/0300-1/98A	FITTING, elbow, straight, 90, 1/4 npt, male/female	1
1306	82/0237-GL/25	RAM, 2-post, 8.5:1, stainless steel, 1 gallon	1



# 5 Gallon Lid with Diaphragm Pump

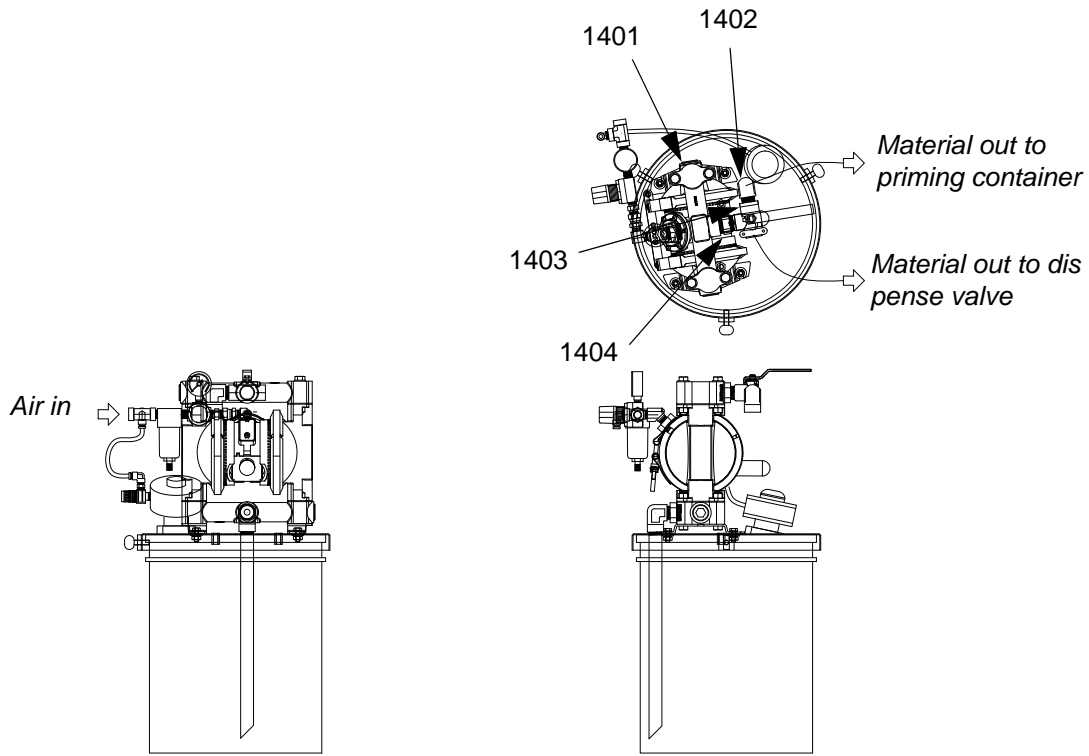

Ref	Part	Description	Quantity	
			SUPPLY UNIT, no agitator	SUPPLY UNIT, with agitator
1401	U50184	PUMP, 1:1, 5 gallon, with dip tube, stainless steel, no agitator	1	
	U50185	PUMP, 1:1, 5 gallon, with dip tube, stainless steel, agitator		1
1402	94/0301-1/98	FITTING, elbow, straight, 90, 1/2 npt, stainless steel	1	1
1403	94/0791/98	VALVE, ball, 3w, 1/2 in. female, 800 psi, stainless steel	1	1
1404	94/0562/98	FITTING, nipple, hex, 3/4 npt x 1/2 npt, male/male	1	1

## 5 Gallon Lid with 5:1 Monark Stainless Steel Pump

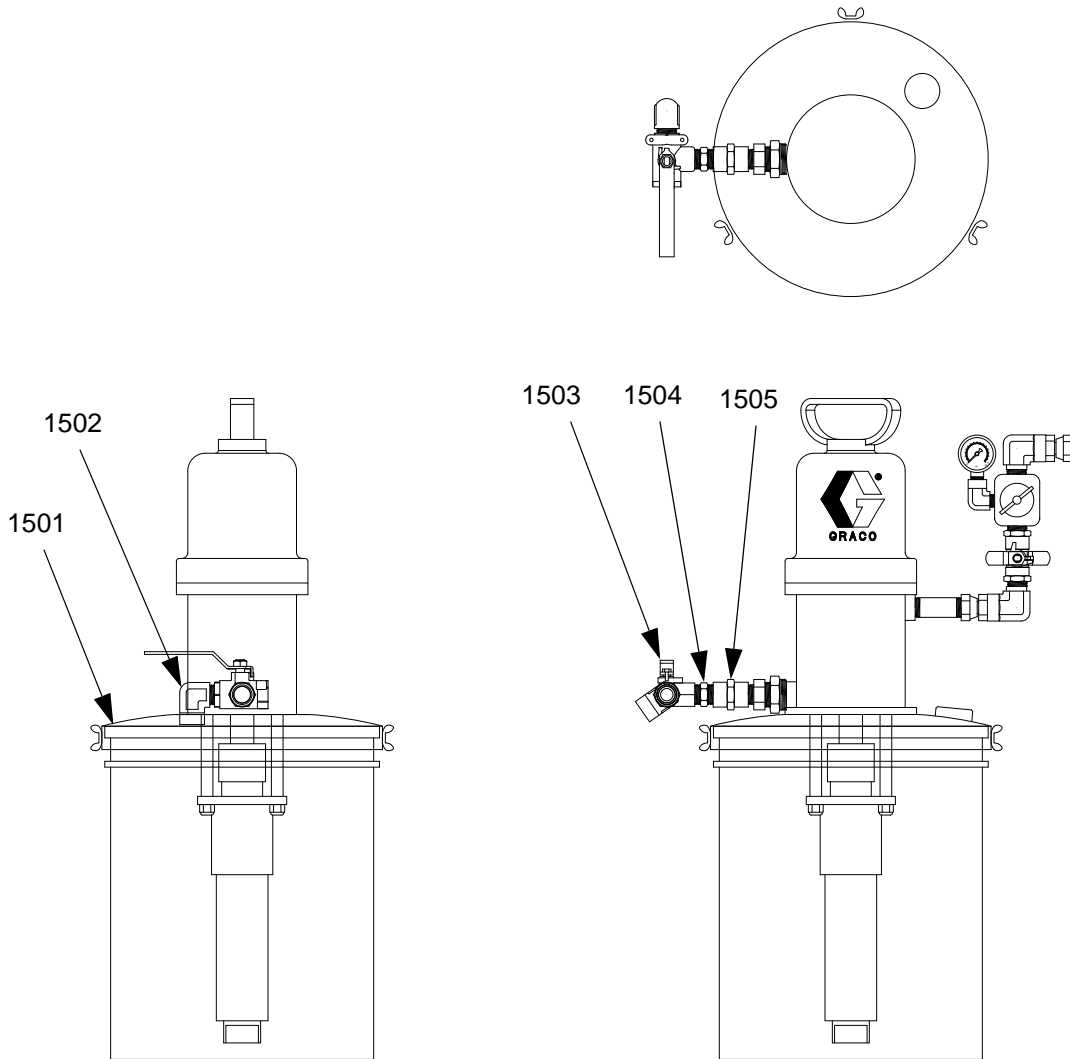

Ref	Part	Description	Qty
1501	82/0771-SP/25	PUMP, 5:1, stainless steel, PTFE	1
1502	94/0301-1/98	FITTING, elbow, straight, 90, 1/2 npt, stainless steel	1
1503	94/0791/98	VALVE, ball, 3w, 1/2 in. female, 800 psi, stainless steel	1
1504	94/0520/98	FITTING, nipple, hex, 1/2 npt, male/male, stainless steel	1
1505	94/0380/98	COUPLING, hex, 1/2npt, female/female, stainless steel	1

## 5 Gallon Lid with Stainless Steel Diaphragm Pump

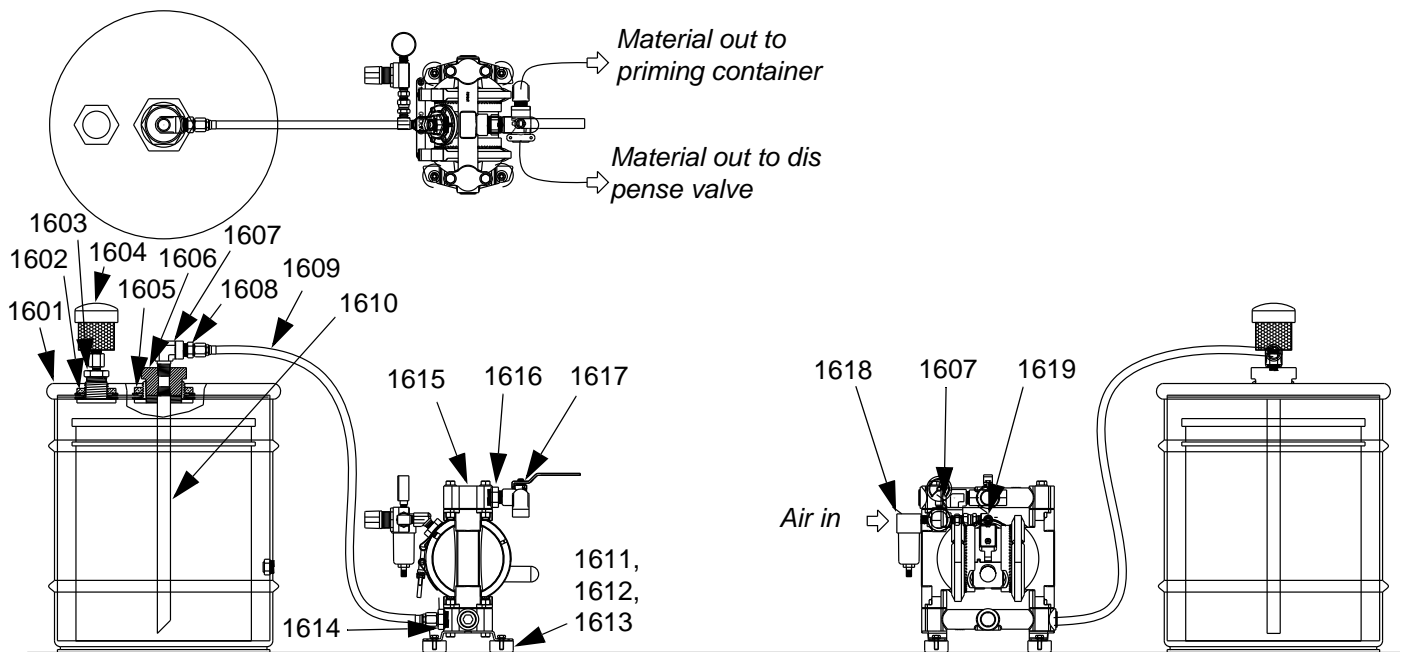

Ref	Part	Description	Qty	Ref	Part	Description	Qty
1601	01/3917/98	PAIL, 10 gallon, ring-belt, lid	1	1617	94/0791/98	VALVE, ball, 3w, 1/2 in. female, 800 psi, stainless steel	1
1602	94/0464-100/25	FITTING, bulkhead, 1 in. nptf, polyethylene, fluoroelastomer	1	1618	02/0023/50	KIT, connection, air, 1/4 npt	1
1603	94/0615/98	BUSHING, 1 npt x 1/4 npt, male/female, stainless steel, 3k, 304	1	1619	94/0506/96	FITTING, elbow, straight, 1/4 npt, 90, brass	1
1604	82/0169/25	DRYER, disposable, w/ adapter	1				
1605	94/0464-200/25	FITTING, bulkhead, 2 in. nptf, polyethylene, fluoroelastomer	1				
1606	01/3915/98	PLUG, 2 in. nptm x 1/2 nptf, stainless steel	1				
1607	94/0301-1/98	FITTING, elbow, straight, 90, 1/2 npt, stainless steel	2				
1608	16C398	FITTING, adapter, 1/2 npt x 08 JIC, 6k, stainless steel	1				
1609	16C530	HOSE, assembly, stainless steel braid, 1/2 x 36, stainless steel	1				
1610	01/3916/98	TUBE, dip, 1/2 npt, 16 in. long, stainless steel	1				
1611	109058	SCREW, cap, hex head	4				
1612	104123	WASHER, lock, spring	4				
1613	84/0400/11	BUMPER, rubber, 1-1/2 x 3/4, 1/4 dia, t	4				
1614	94/1040/98	ADAPTER, JIC 08 x 3/4 npt, male/male, stainless steel, 2.5k, 3	1				
1615	257447	PUMP, Husky, stainless steel	1				
1616	94/0562/98	FITTING, nipple, hex, 3/4 npt x 1/2 npt, male/male	1				

# 5 Gallon Tank Assembly with Diaphragm Pump

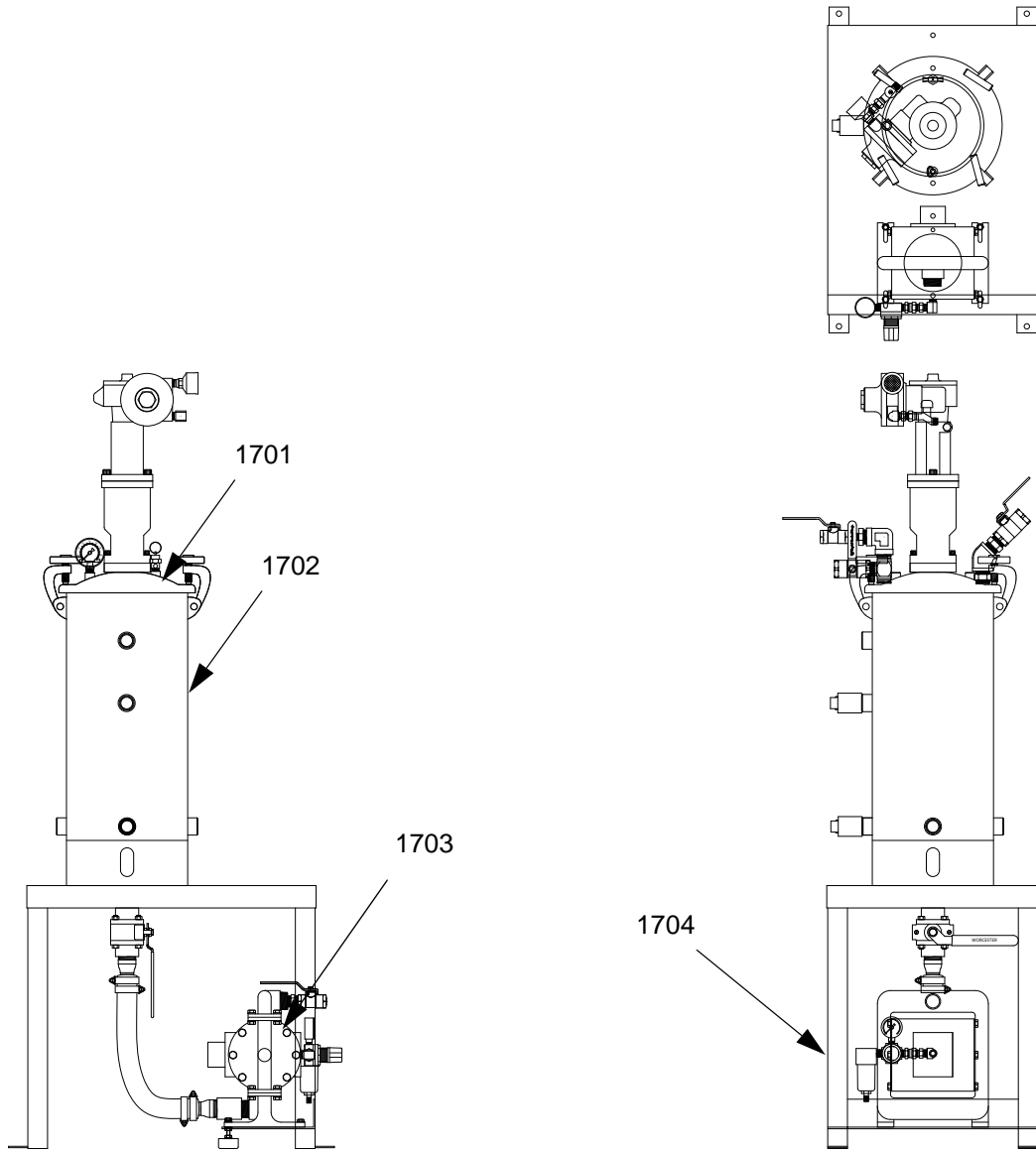

Ref	Part	Description	Quantity					
			Mild Steel Tank	Mild Steel Tank, Pneumatic Agitator	Mild Steel, Vacuum Fill	Stainless Steel Tank	Stainless Steel Tank, Pneumatic Agitator	Stainless Steel, Vacuum Fill
1701	02/1030-18/25	LID, 5 gallon, stainless steel, relief, vent	1			1		
	02/1030-15/25	LID, 5 gallon, mild steel, pneumatic agitator		1				
	02/1030-13/25	LID, 5 gallon, mild steel, pneumatic agitator, vacuum, fill			1			
	02/1030-14/25	LID, 5 gallon, stainless steel, pneumatic agitator					1	
	02/1030-12/25	LID, 5 gallon, stainless steel, pneumatic agitator, vacuum, fill						1
1702	02/1030-22/25	TANK, 5 gallon, mild steel, low sensor	1	1				
	02/1030-9/25	TANK, 5 gallon, mild steel, low/high sensors			1			
	02/1030-21/25	TANK, 5 gallon, stainless steel, low sensor				1	1	
	02/1030-6/25	TANK, 5 gallon, stainless steel, low/high sensor						1
1703	02/1030-3/25	PUMP, diaphragm, stainless steel, 1/2 npt	1	1	1	1	1	1
1704	02/1030-23/25	SUPPORT, tank	1	1	1	1	1	1

# 5 Gallon Tank Assembly with 5:1 Monark Stainless Steel Pump

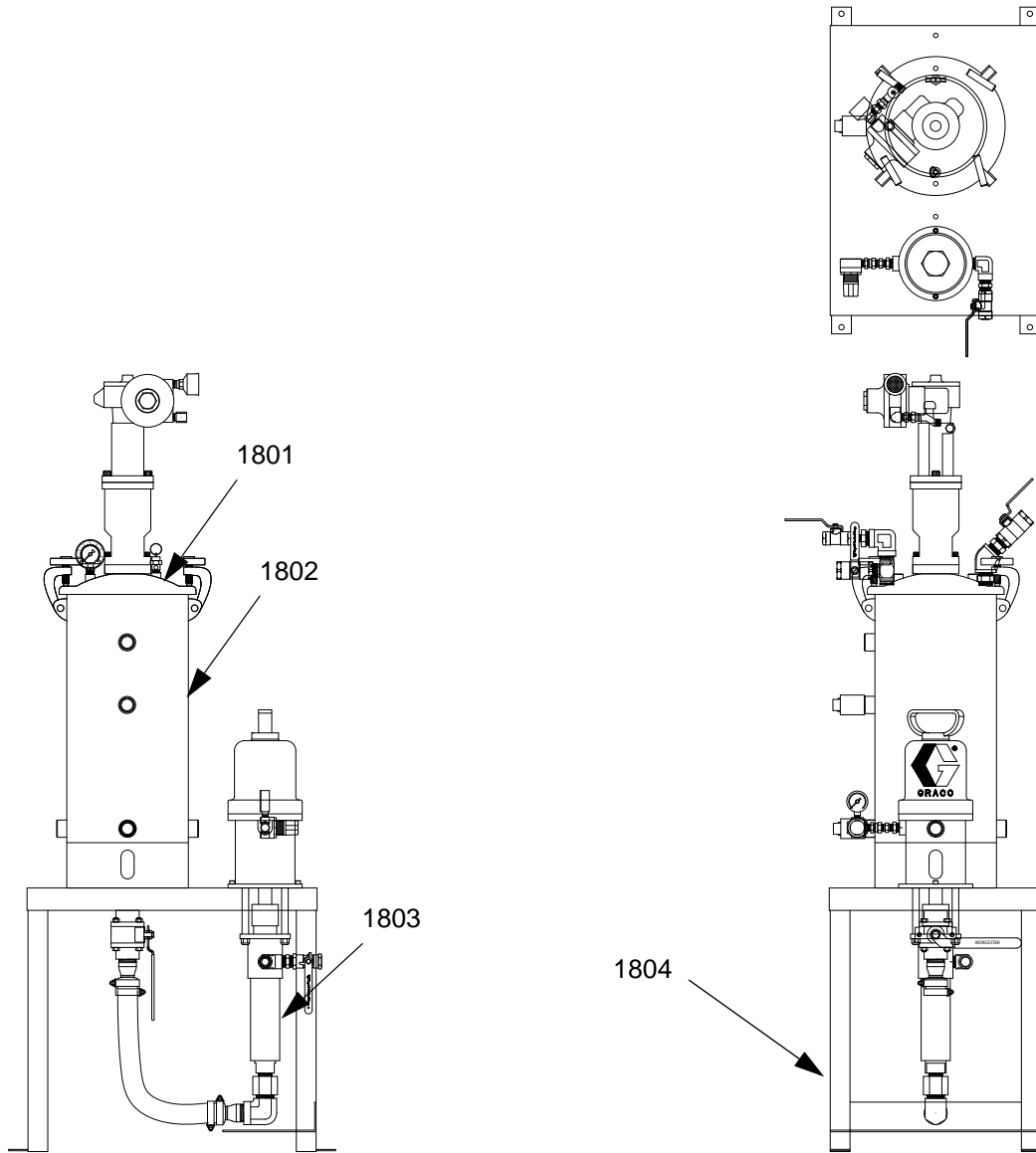

Ref	Part	Description	Quantity					
			Mild Steel Tank	Mild Steel Tank, Pneumatic Agitator	Mild Steel, Vacuum Fill	Stainless Steel Tank	Stainless Steel Tank, Pneumatic Agitator	Stainless Steel, Vacuum Fill
1801	02/1030-18/25	LID, 5 gallon, stainless steel, relief, vent	1			1		
	02/1030-15/25	LID, 5 gallon, mild steel, pneumatic agitator		1				
	02/1030-13/25	LID, 5 gallon, mild steel, pneumatic agitator, vacuum, fill			1			
	02/1030-14/25	LID, 5 gallon, stainless steel, pneumatic agitator					1	
	02/1030-12/25	LID, 5 gallon, stainless steel, pneumatic agitator, vacuum, fill						1
1802	02/1030-22/25	TANK, 5 gallon, mild steel, low sensor	1	1				
	02/1030-9/25	TANK, 5 gallon, mild steel, low/high sensors			1			
	02/1030-21/25	TANK, 5 gallon, stainless steel, low sensor				1	1	
	02/1030-6/25	TANK, 5 gallon, stainless steel, low/high sensor						1
1803	02/1030-4/25	PUMP, 5:1, stainless steel, PTFE/polyethylene	1	1	1	1	1	1
1804	02/1030-23/25	SUPPORT, tank	1	1	1	1	1	1

# 10 Gallon Tank Assemblies with Diaphragm Pump

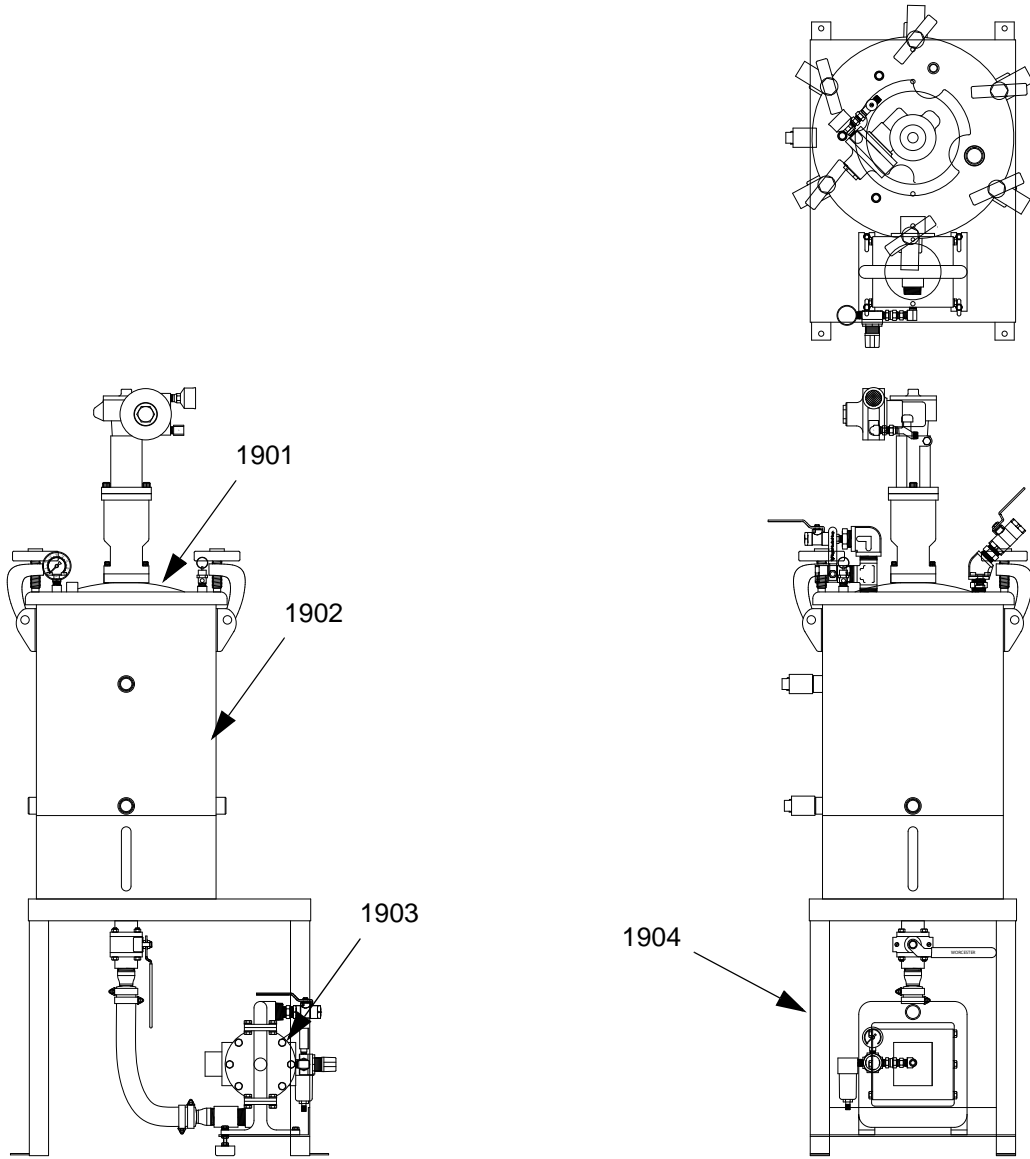



Ref	Part	Description	Quantity					
			Mild Steel Tank	Mild Steel Tank, Pneumatic Agitator	Mild Steel Tank, Pneumatic Agitator, Vacuum Fill	Stainless Steel Tank	Stainless Steel Tank, Pneumatic Agitator	Stainless Steel Tank, Pneumatic Agitator, Vacuum Fill
1901	02/1030-19/25	LID, tank, 10 gallon, mild steel, relief, vent	1					
	02/1030-11/25	LID, 10 gallon, mild steel, pneumatic agitator		1				
	02/1030-10/25	LID, 10 gallon, mild steel, pneumatic agitator, vacuum, fill			1			
	02/1030-20/25	LID, tank, 10 gallon, stainless steel, relief, vent				1		
	02/1030-7/25	LID, 10 gallon, stainless steel, pneumatic agitator					1	
	02/1030-8/25	LID, 10 gallon, stainless steel, pneumatic agitator, vacuum, fill						1
1902	02/1030-24/25	TANK, 10 gallon, mild steel, low sensor	1					
	02/1030-2/25	TANK, 10 gallon, mild steel, low/high sensors		1				
	02/1030-32/25	TANK, 10 gallon, mild steel, low/high sensors, vacuum			1			
	02/1030-25/25	TANK, 10 gallon, stainless steel, low sensor				1		
	02/1030-5/25	TANK, 10 gallon, stainless steel, low/high sensors					1	
	02/1030-33/25	TANK, 10 gallon, stainless steel, low/high sensors, vacuum						1
1903	02/1030-3/25	PUMP, diaphragm, stainless steel, 1/2 npt	1	1	1	1	1	1
1904	02/1030-23/25	SUPPORT, tank	1	1	1	1	1	1

# 10 Gallon Tank Assemblies with 5:1 Monark Stainless Steel Pump

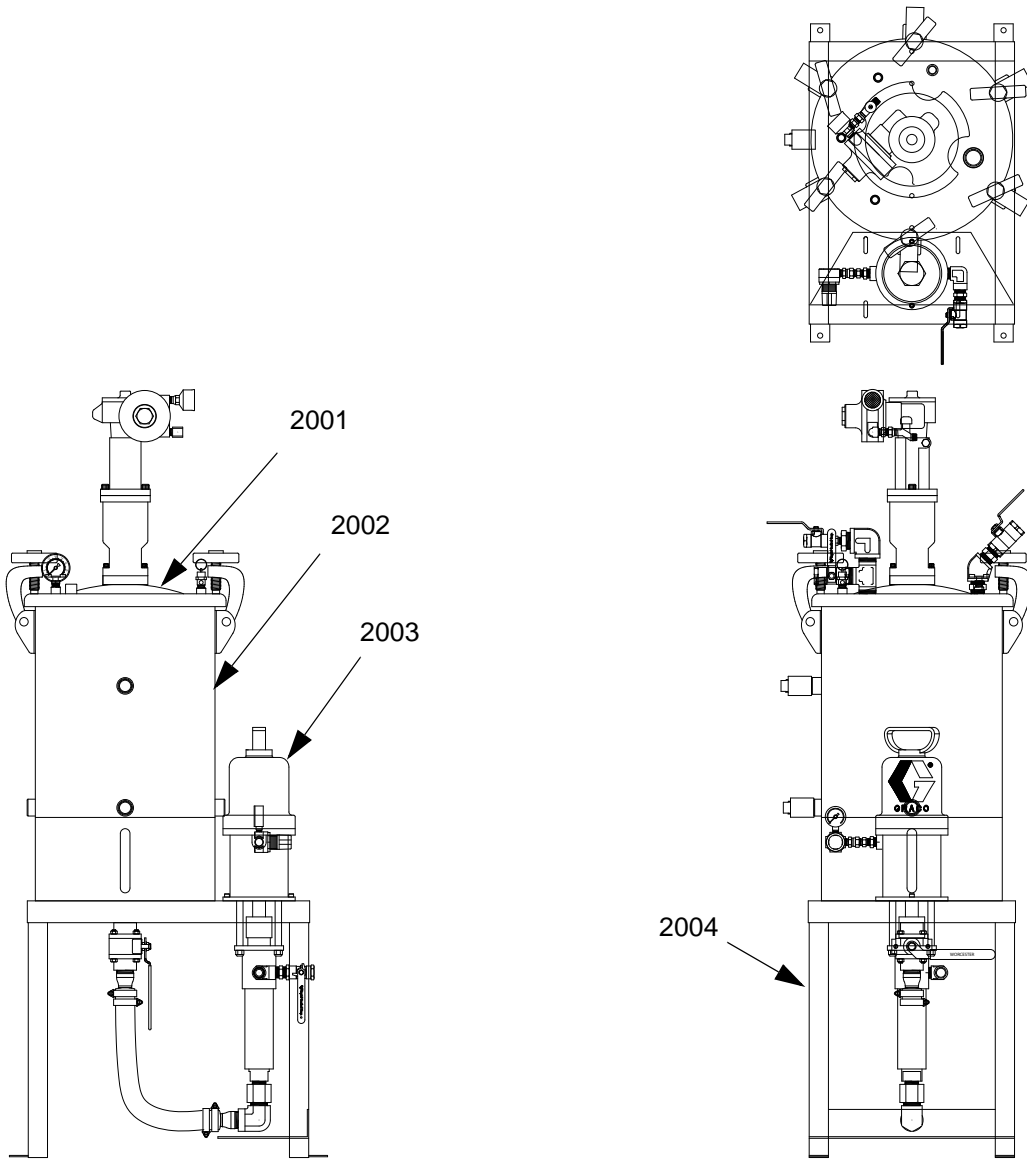

Ref	Part	Description	Quantity					
			Mild Steel Tank	Mild Steel Tank, Pneumatic Agitator	Mild Steel Tank, Pneumatic Agitator, Vacuum Fill	Stainless Steel Tank	Stainless Steel Tank, Pneumatic Agitator	Stainless Steel Tank, Pneumatic Agitator, Vacuum Fill
2001	02/1030-19/25	LID, tank, 10 gallon, mild steel, relief, vent	1					
	02/1030-11/25	LID, 10 gallon, mild steel, pneumatic agitator		1				
	02/1030-10/25	LID, 10 gallon, mild steel, pneumatic agitator, vacuum, fill			1			
	02/1030-20/25	LID, tank, 10 gallon, stainless steel, relief, vent				1		
	02/1030-7/25	LID, 10 gallon, stainless steel, pneumatic agitator					1	
	02/1030-8/25	LID, 10 gallon, stainless steel, pneumatic agitator, vacuum, fill						1
2002	02/1030-24/25	TANK, 10 gallon, mild steel, lo	1					
	02/1030-2/25	TANK, 10 gallon, mild steel, lo, hi		1				
	02/1030-32/25	TANK, 10 gallon, mild steel, lo, hi, vacuum			1			
	02/1030-25/25	TANK, 10 gallon, stainless steel, lo				1		
	02/1030-5/25	TANK, 10 gallon, stainless steel, lo, hi					1	
	02/1030-33/25	TANK, 10 gallon, stainless steel, lo, hi, vacuum						1
2003	02/1030-4/25	PUMP, 5:1, stainless steel, PTFE/polyethylene	1	1	1	1	1	1
2004	02/1030-23/25	SUPPORT, tank	1	1	1	1	1	1

# Micrometer and LRT Logic

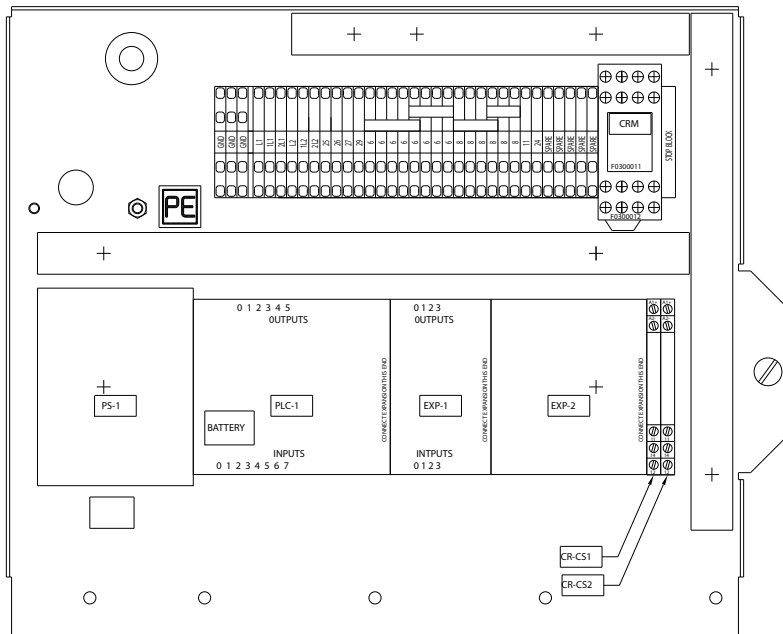
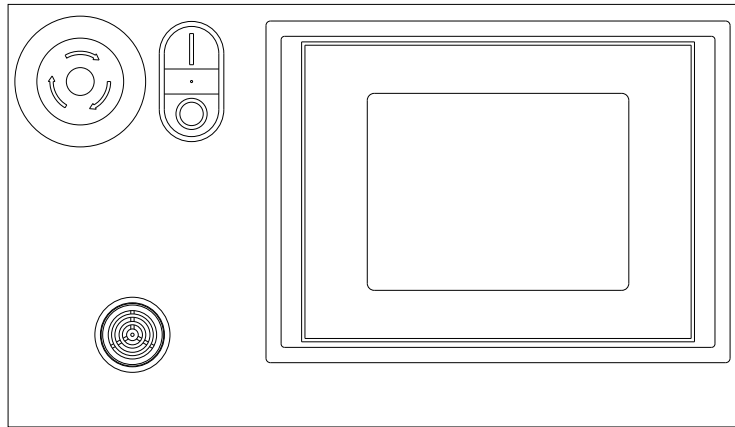
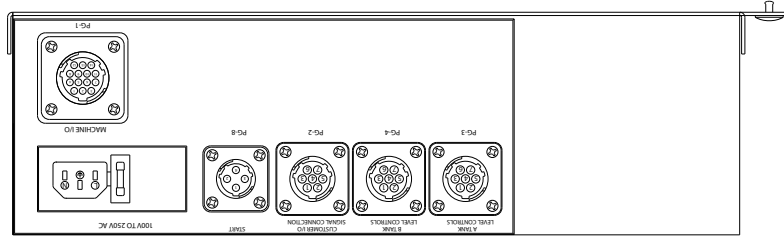

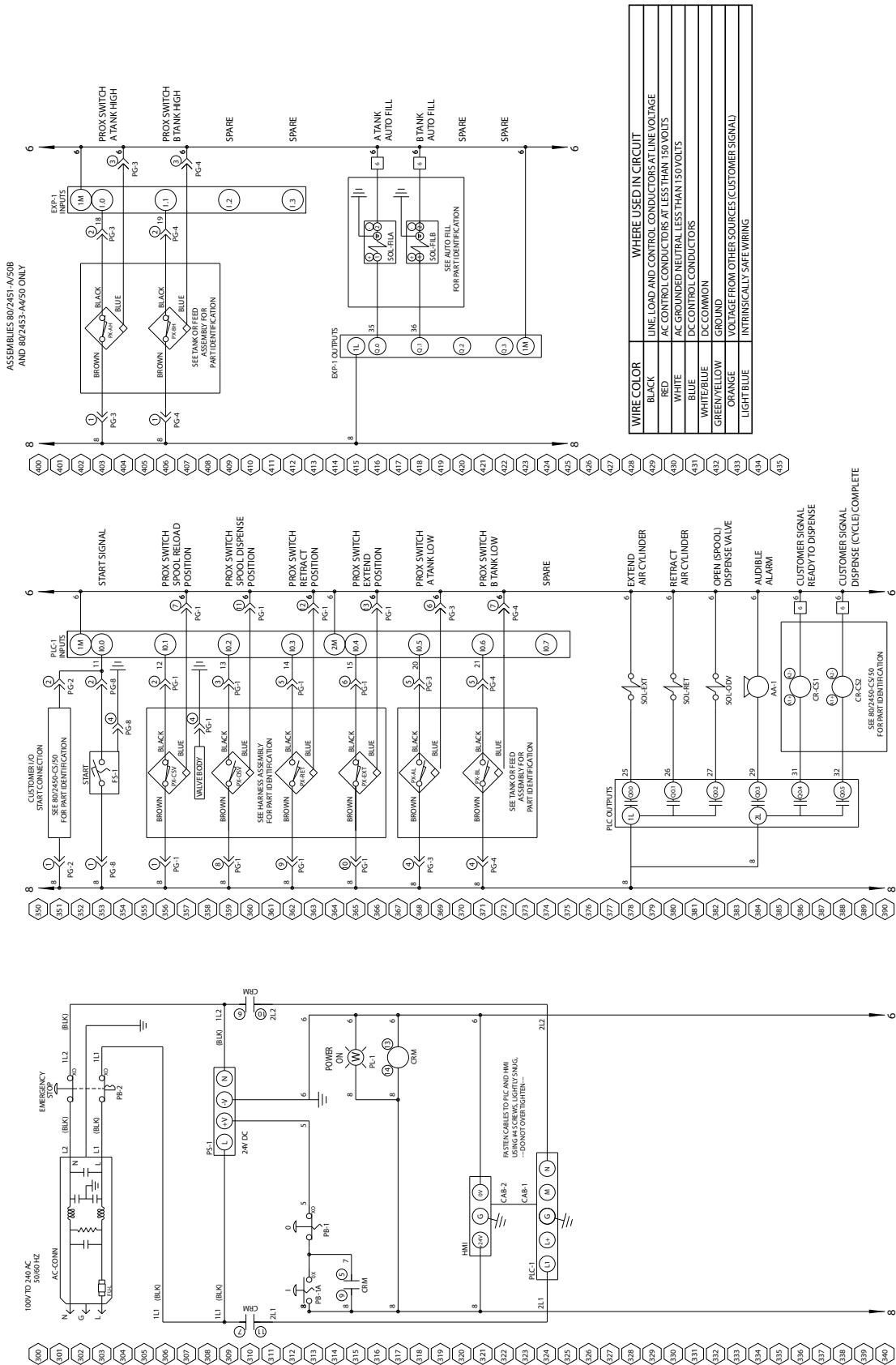



# Micrometer and LRT Optional Customer Inputs

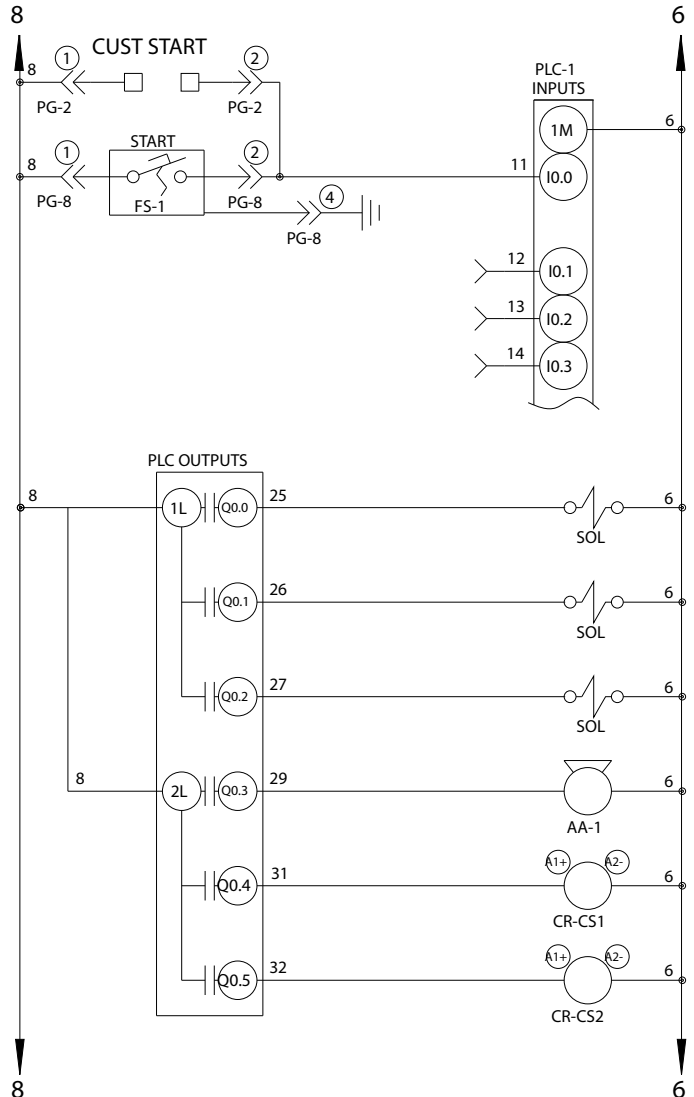
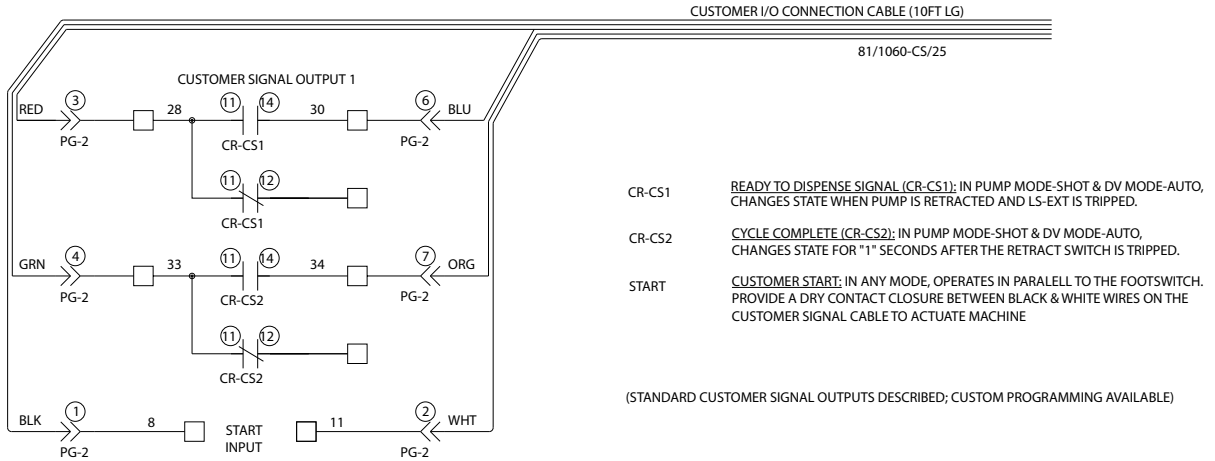







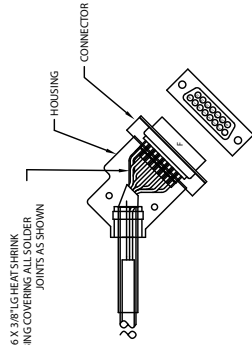

PG-2

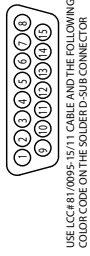

USE LOCAL WIRE COLOR CODE AND THE FOLLOWING COLOR CODE ON THE SOLDERED SUB CONNECTOR

PIN #	USAGE	WIRE #	WIRE COLOR
1	VDC COMMON	6	WHT/BLK
2	+24VDC	8	WHT
3	PX-HOME	16	RED/BLK
4	VDC COMMON	6	GRN/BLK
5	+24VDC	8	BLU
6	PX-DN	19	BLK/WHT
7	PX-UP	20	BLU/WHT
8	+24VDC	8	RED/WHT
9	LS-CSV	30	BLU/BLK
10	LS-OSV	31	ORG/BLK
11	SOL-CSV-SIGNAL	56	RED
12	GROUND	GND	GRN/WHT
13	SOL-CSV-COMMON	6	BLK
14	SOL-OSV	57	GRN
15	VDC COMMON	6	ORG

NOTE: USE LEAD FREE SOLDER

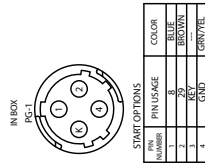

PIN NUMBER	PIN USAGE	COLOR
1	---	---
2	---	---
3	---	---
4	---	---

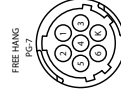

PIN NUMBER	PIN USAGE	COLOR
1	---	---
2	---	---
3	---	---
4	---	---
5	---	---
6	---	---

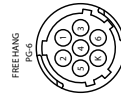

PIN NUMBER	PIN USAGE	COLOR
1	---	---
2	---	---
3	---	---
4	---	---
5	---	---
6	---	---

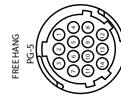

PIN NUMBER	PIN USAGE
1	JUMPER
2	JUMPER
3	JUMPER
4	RED
5	WHT
6	WHT
7	GRN
8	JUMPER
9	---
10	---
11	---
12	---
13	---
14	---

REFERENCE WIRE FERRULE CHART

WIRE SIZE	PART NUMBER	COLOR
12AWG	810723/11	GRAY
14AWG	810722/11	BLUE
16AWG	810724/11	BLACK
18AWG	810721/11	RED
20-22AWG	810720/11	WHITE
24AWG	810725/11	LT. BLUE

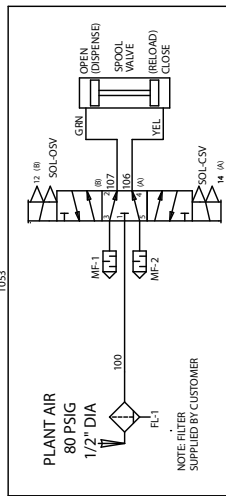
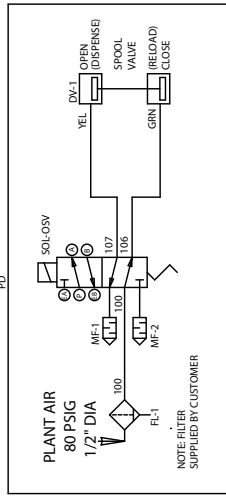

GROUNDING NOTES:

1. PLACE LABEL 84/0130-26/11 "PE" AT EXTERNAL PROTECTIVE CONDUCTOR (GROUND STUD).
2. NO PAINT UNDER GROUND STUD.
3. REFER TO FIGURE 1 FOR GROUND STUD DETAIL.
9. GROUND ALL DOORS
10. SHIELD CABLE TO BE CONNECTED AT ONE END TO TERMINAL GROUND.
11. DO NOT WIRE TIE POWER WIRES WITH SIGNAL WIRES.
12. DO NOT WIRE TIE POWER WIRES WITH SIGNAL WIRES. SEE FIGURE 2

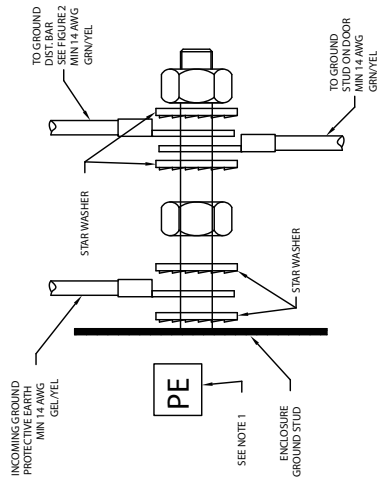

FIGURE 1 NTS

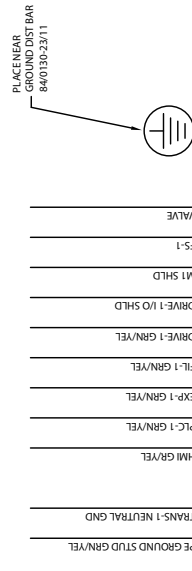

FIGURE 2 NTS



# Graco Standard Warranty

Graco warrants all equipment referenced in this document which is manufactured by Graco and bearing its name to be free from defects in material and workmanship on the date of sale to the original purchaser for use. With the exception of any special, extended, or limited warranty published by Graco, Graco will, for a period of twelve months from the date of sale, repair or replace any part of the equipment determined by Graco to be defective. This warranty applies only when the equipment is installed, operated and maintained in accordance with Graco's written recommendations.

This warranty does not cover, and Graco shall not be liable for general wear and tear, or any malfunction, damage or wear caused by faulty installation, misapplication, abrasion, corrosion, inadequate or improper maintenance, negligence, accident, tampering, or substitution of non-Graco component parts. Nor shall Graco be liable for malfunction, damage or wear caused by the incompatibility of Graco equipment with structures, accessories, equipment or materials not supplied by Graco, or the improper design, manufacture, installation, operation or maintenance of structures, accessories, equipment or materials not supplied by Graco.

This warranty is conditioned upon the prepaid return of the equipment claimed to be defective to an authorized Graco distributor for verification of the claimed defect. If the claimed defect is verified, Graco will repair or replace free of charge any defective parts. The equipment will be returned to the original purchaser transportation prepaid. If inspection of the equipment does not disclose any defect in material or workmanship, repairs will be made at a reasonable charge, which charges may include the costs of parts, labor, and transportation.

**THIS WARRANTY IS EXCLUSIVE, AND IS IN LIEU OF ANY OTHER WARRANTIES, EXPRESS OR IMPLIED, INCLUDING BUT NOT LIMITED TO WARRANTY OF MERCHANTABILITY OR WARRANTY OF FITNESS FOR A PARTICULAR PURPOSE.**

Graco's sole obligation and buyer's sole remedy for any breach of warranty shall be as set forth above. The buyer agrees that no other remedy (including, but not limited to, incidental or consequential damages for lost profits, lost sales, injury to person or property, or any other incidental or consequential loss) shall be available. Any action for breach of warranty must be brought within two (2) years of the date of sale.

**GRACO MAKES NO WARRANTY, AND DISCLAIMS ALL IMPLIED WARRANTIES OF MERCHANTABILITY AND FITNESS FOR A PARTICULAR PURPOSE, IN CONNECTION WITH ACCESSORIES, EQUIPMENT, MATERIALS OR COMPONENTS SOLD BUT NOT MANUFACTURED BY GRACO.** These items sold, but not manufactured by Graco (such as electric motors, switches, hose, etc.), are subject to the warranty, if any, of their manufacturer. Graco will provide purchaser with reasonable assistance in making any claim for breach of these warranties.

In no event will Graco be liable for indirect, incidental, special or consequential damages resulting from Graco supplying equipment hereunder, or the furnishing, performance, or use of any products or other goods sold hereto, whether due to a breach of contract, breach of warranty, the negligence of Graco, or otherwise.

## **FOR GRACO CANADA CUSTOMERS**

The Parties acknowledge that they have required that the present document, as well as all documents, notices and legal proceedings entered into, given or instituted pursuant hereto or relating directly or indirectly hereto, be drawn up in English. Les parties reconnaissent avoir convenu que la rédaction du présente document sera en Anglais, ainsi que tous documents, avis et procédures judiciaires exécutés, donnés ou intentés, à la suite de ou en rapport, directement ou indirectement, avec les procédures concernées.

# Graco Information

For the latest information about Graco products, visit [www.graco.com](http://www.graco.com).

For patent information, see [www.graco.com/patents](http://www.graco.com/patents).

**TO PLACE AN ORDER, contact your Graco distributor or call to identify the nearest distributor.**

**Toll Free: 1-800-746-1334 or Fax: 330-966-3006**

*All written and visual data contained in this document reflects the latest product information available at the time of publication. Graco reserves the right to make changes at any time without notice.*

*For patent information, see [www.graco.com/patents](http://www.graco.com/patents).*

Original instructions. This manual contains English. MM 3A0987

**Graco Headquarters:** Minneapolis

**International Offices:** Belgium, China, Japan, Korea

**GRACO INC. AND SUBSIDIARIES • P.O. BOX 1441 • MINNEAPOLIS MN 55440-1441 • USA**

**Copyright 2011, Graco Inc. All Graco manufacturing locations are registered to ISO 9001.**

[www.graco.com](http://www.graco.com)

Revision L, February 2016