

Automatic AirPro[®] Spray Guns

313516G
EN

**Conventional, HVLP, and Compliant guns for spraying paints and coatings.
For professional use only.**

See page 2 for model information.

*100 psi (0.7 MPa, 7 bar) Maximum Working Fluid Pressure
100 psi (0.7 MPa, 7 bar) Maximum Working Air Pressure*



Important Safety Instructions

Read all warnings and instructions in this manual. Save these instructions.

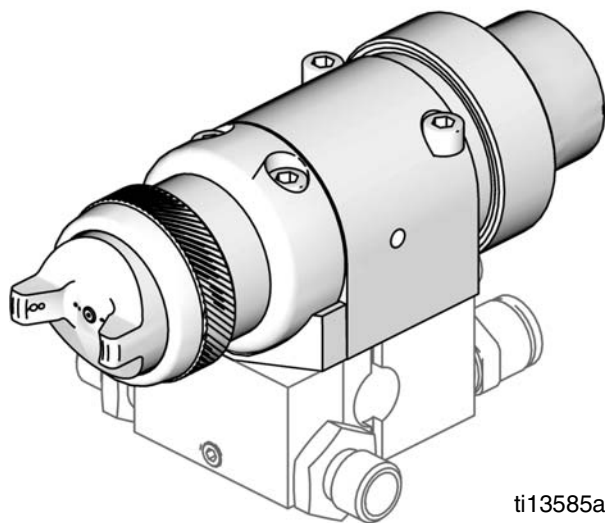

ti13585a

Part 24A749 Conventional Gun shown mounted on Part 288217 Manifold.

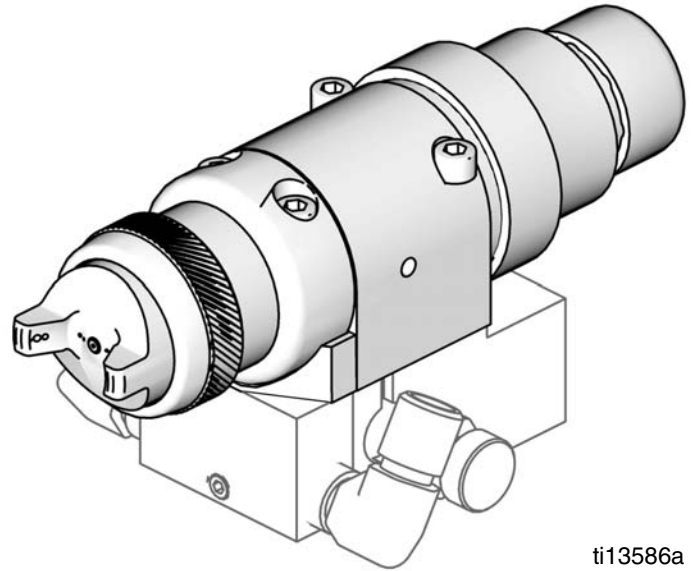

ti13586a

Part 24A753 Conventional Gun with fluid control shown mounted on Part 288223 Manifold.



Contents

Models	2	Parts	26
Warnings	3	Repair Kits	28
Selection Charts	5	Accessories	34
Air Flow	8	Dimensions	36
Installation	10	Mounting Hole Layouts	38
Setup	14	Technical Data	43
Operation	18	Graco Standard Warranty	44
Troubleshooting	21	Graco Information	44
Service	23		



Models

NOTE: A manifold is required for each gun to be installed. Refer to the **Parts** section for manifold information.

Application	Orifice Size in. (mm)	Conventional	HVLP	Compliant
General Metal	0.020 (0.5)	24B333	24B334	24B335
General Metal	0.030 (0.8)	24A747	24A754	24A761
General Metal	0.042 (1.1)	24A748	24A755	24A762
General Metal	0.055 (1.4)	24A749	24A756	24A763
General Metal	0.070 (1.8)	24A750	24A757	24A764
General Metal with Fluid Control Knob	0.030 (0.8)	24A751	24A758	24A765
General Metal with Fluid Control Knob	0.042 (1.1)	24A752	24A759	24A766
General Metal with Fluid Control Knob	0.055 (1.4)	24A753	24A760	24A767
High Wear	0.059 (1.5)	24A774	24A776	24A778
High Wear	0.070 (1.8)	24A775	24A777	24A779
High Wear	0.086 (2.2)	24B336		
High Wear	0.110 (2.8)	24C316		
Wood	0.030 (0.8)	24A768	24A770	24A772
Wood	0.040 (1.0)	24A769	24A771	24A773

Warnings

The following warnings are for the setup, use, grounding, maintenance, and repair of this equipment. The exclamation point symbol alerts you to a general warning and the hazard symbol refers to procedure-specific risk. Refer back to these warnings. Additional, product-specific warnings may be found throughout the body of this manual where applicable.

 WARNING	
	<p>FIRE AND EXPLOSION HAZARD</p> <p>Flammable fumes, such as solvent and paint fumes, in work area can ignite or explode. To help prevent fire and explosion:</p> <ul style="list-style-type: none"> • Use equipment only in well ventilated area. • Eliminate all ignition sources; such as pilot lights, cigarettes, portable electric lamps, and plastic drop cloths (potential static arc). • Keep work area free of debris, including solvent, rags and gasoline. • Do not plug or unplug power cords, or turn power or light switches on or off when flammable fumes are present. • Ground all equipment in the work area. • Use only grounded hoses. • Hold gun firmly to side of grounded pail when triggering into pail. • If there is static sparking or you feel a shock, stop operation immediately. Do not use equipment until you identify and correct the problem. • Keep a working fire extinguisher in the work area.
	<p>EQUIPMENT MISUSE HAZARD</p> <p>Misuse can cause death or serious injury.</p> <ul style="list-style-type: none"> • Do not operate the unit when fatigued or under the influence of drugs or alcohol. • Do not exceed the maximum working pressure or temperature rating of the lowest rated system component. See Technical Data in all equipment manuals. • Do not leave the work area while equipment is energized or under pressure. Turn off all equipment and follow the Pressure Relief Procedure in this manual when equipment is not in use. • Check equipment daily. Repair or replace worn or damaged parts immediately with genuine manufacturer's replacement parts only. • Do not alter or modify equipment. • Use equipment only for its intended purpose. Call your distributor for information. • Route hoses and cables away from traffic areas, sharp edges, moving parts, and hot surfaces. • Do not kink or over bend hoses or use hoses to pull equipment. • Keep children and animals away from work area. • Comply with all applicable safety regulations.

WARNING



PRESSURIZED EQUIPMENT HAZARD

Fluid from the gun/dispense valve, leaks, or ruptured components can splash in the eyes or on skin and cause serious injury.

- Follow **Pressure Relief Procedure** in this manual, when you stop spraying and before cleaning, checking, or servicing equipment.
- Tighten all fluid connections before operating the equipment.
- Check hoses, tubes, and couplings daily. Replace worn or damaged parts immediately.



TOXIC FLUID OR FUMES HAZARD

Toxic fluids or fumes can cause serious injury or death if splashed in the eyes or on skin, inhaled, or swallowed.

- Read MSDS's to know the specific hazards of the fluids you are using.
- Store hazardous fluid in approved containers, and dispose of it according to applicable guidelines.
- Always wear impervious gloves when spraying or cleaning equipment.



PERSONAL PROTECTIVE EQUIPMENT

You must wear appropriate protective equipment when operating, servicing, or when in the operating area of the equipment to help protect you from serious injury, including eye injury, inhalation of toxic fumes, burns, and hearing loss. This equipment includes but is not limited to:

- Protective eyewear
- Clothing and respirator as recommended by the fluid and solvent manufacturer
- Gloves
- Hearing protection

Selection Charts

TERMS

Light Fluid: Up to 18 seconds with No. 2 Zahn cup (20 centipoise)

Medium Fluid: 19 to 28 seconds with No. 2 Zahn cup (20-64 centipoise)

Heavy Fluid: Greater than 28 seconds with No. 2 Zahn cup (greater than 64 centipoise) -- 2.8 Volatile Organic Compounds, High-solid Polyurethanes, Heavy Waterborne Enamels

General Metal Applications

Gun Assembly Part No.	Type	Includes:		Air Cap Part No. (without pin, for reference)	Orifice Size in. (mm)	Material Usage	
		Needle/Nozzle Kit Part No.	Air Cap with Pin Part No.			Viscosity	Flow oz./min. (l/min.)
24B333	Conventional	24B332	24B544	289773	0.020 (0.5)	light	2–6 (0.06–0.18)
24A747	Conventional	24A687	24B544	289773	0.030 (0.8)	light	4–10 (0.12–0.30)
24A748	Conventional	24A688	24B544	289773	0.042 (1.1)	light-medium	8–14 (0.24–0.42)
24A749	Conventional	24A689	24B544	289773	0.055 (1.4)	medium	12–18 (0.36–0.54)
24A750	Conventional	24A690	24B545	289784	0.070 (1.8)	medium-heavy	16–20 (0.48–0.60)
24B334	HVLP	24B332	24B539	289041	0.020 (0.5)	light	2–6 (0.06–0.18)
24A754	HVLP	24A687	24B539	289041	0.030 (0.8)	light	4–10 (0.12–0.30)
24A755	HVLP	24A688	24B539	289041	0.042 (1.1)	light-medium	8–14 (0.24–0.42)
24A756	HVLP	24A689	24B539	289041	0.055 (1.4)	medium	12–18 (0.36–0.54)
24A757	HVLP	24A690	24B539	289041	0.070 (1.8)	medium-heavy	16–20 (0.48–0.60)
24B335	Compliant	24B332	24B540	289042	0.020 (0.5)	light	2–6 (0.06–0.18)
24A761	Compliant	24A687	24B540	289042	0.030 (0.8)	light	4–10 (0.12–0.30)
24A762	Compliant	24A688	24B540	289042	0.042 (1.1)	light-medium	8–14 (0.24–0.42)
24A763	Compliant	24A689	24B540	289042	0.055 (1.4)	medium	12–18 (0.36–0.54)
24A764	Compliant	24A690	24B540	289042	0.070 (1.8)	medium-heavy	16–20 (0.48–0.60)
24A751★	Conventional	24A687	24B544	289773	0.030 (0.8)	light	4–10 (0.12–0.30)
24A752★	Conventional	24A688	24B544	289773	0.042 (1.1)	light-medium	8–14 (0.24–0.42)
24A753★	Conventional	24A689	24B544	289773	0.055 (1.4)	medium	12–18 (0.36–0.54)
24A758★	HVLP	24A687	24B539	289041	0.030 (0.8)	light	4–10 (0.12–0.30)
24A759★	HVLP	24A688	24B539	289041	0.042 (1.1)	light-medium	8–14 (0.24–0.42)
24A760★	HVLP	24A689	24B539	289041	0.055 (1.4)	medium	12–18 (0.36–0.54)
24A765★	Compliant	24A687	24B540	289042	0.030 (0.8)	light	4–10 (0.12–0.30)
24A766★	Compliant	24A688	24B540	289042	0.042 (1.1)	light-medium	8–14 (0.24–0.42)
24A767★	Compliant	24A689	24B540	289042	0.055 (1.4)	medium	12–18 (0.36–0.54)

★ *With Fluid Control Knob (for fine adjustment of fluid flow).*

High Wear Applications

Gun Assembly Part No.	Type	Includes:		Air Cap Part No. (without pin, for reference)	Orifice Size in. (mm)	Material Usage	
		Needle/ Nozzle Kit Part No.	Air Cap with Pin Part No.			Viscosity	Flow oz./min. (l/min.)
24A774✕	Conventional	24A693	24B537	288861	0.059 (1.5)	medium	12–18 (0.36–0.54)
24A775✕	Conventional	24A694	24B536	289049	0.070 (1.8)	medium-heavy	16–20 (0.48–0.60)
24B336✕	Conventional	24B358	24B536	289049	0.086 (2.2)	heavy	>20 (>0.60)
24C316✕	Conventional	24C142	24B536	289049	0.110 (2.8)	heavy	>25 (>0.74)
24A776✕	HVLP	24A695	24B541	289115	0.059 (1.5)	medium	12–18 (0.36–0.54)
24A777✕	HVLP	24A696	24B542	289325	0.070 (1.8)	medium-heavy	16–20 (0.48–0.60)
24A778✕	Compliant	24A695	24B538	289050	0.059 (1.5)	medium	12–18 (0.36–0.54)
24A779✕	Compliant	24A696	24B543	289327	0.070 (1.8)	medium-heavy	16–20 (0.48–0.60)

✕ Needle tip and nozzle exit constructed from tungsten carbide.

Wood Applications

Gun Assembly Part No.	Type	Includes:		Air Cap Part No. (without pin, for reference)	Orifice Size in. (mm)	Material Usage	
		Needle/ Nozzle Kit Part No.	Air Cap with Pin Part No.			Viscosity	Flow oz./min. (l/min.)
24A768	Conventional	24A691	24B533	288862	0.030 (0.8)	light	4–10 (0.12–0.30)
24A769	Conventional	24A692	24B533	288862	0.040 (1.0)	light-medium	8–14 (0.24–0.42)
24A770	HVLP	24A691	24B535	288864	0.030 (0.8)	light	4–10 (0.12–0.30)
24A771	HVLP	24A692	24B535	288864	0.040 (1.0)	light-medium	8–14 (0.24–0.42)
24A772	Compliant	24A691	24B534	288863	0.030 (0.8)	light	4–10 (0.12–0.30)
24A773	Compliant	24A692	24B534	288863	0.040 (1.0)	light-medium	8–14 (0.24–0.42)

Gun Selection

HVLP Guns

An HVLP gun is a high transfer efficiency gun that limits the air pressure at the air cap to 10 psi (0.07 MPa, 0.7 bar) maximum. In some areas, an HVLP gun is required for compliance with environmental standards. See the Air Cap chart, page 7, for maximum inlet pressures.

Compliant Guns

A compliant gun is a high transfer efficiency gun that has been tested to have a transfer efficiency greater than or equal to HVLP guns. In addition, the compliant air cap consumes much less air than the HVLP air cap. Graco compliant guns have no restrictions on air cap pressures. See the Air Cap chart, page 7, for maximum inlet pressures.

Conventional Guns

An airspray gun has excellent atomization and high production rates typically with some reduction in transfer efficiency.

Proper Needle/Nozzle Selection

The spray gun's needle/nozzle kits range in size to provide different fluid flow rates. As a general guideline, use the fluid nozzle that will give the required flow with the needle fully triggered at a fluid pressure of 5–20 psi (0.035–0.14 MPa, 0.35–1.4 bar).

- For low flow rates or light viscosity fluid, select the smaller nozzle sizes.
- For high flow rates or high viscosity fluid, select the larger nozzle sizes.
- For abrasive fluids, the high wear gun models are recommended.

Air Caps

Air Cap Part No.	Type	Application	Nozzle Orifice in. (mm)	Atomizing Air Max. HVLP/Compliant Manifold Inlet Pressure psi (MPa, bar)	Fan Air Max. HVLP/Compliant Manifold Inlet Pressure psi (MPa, bar)
289773	Conventional	General Metal	0.020–0.055 (0.5–1.4)	N/A	N/A
289784	Conventional	General Metal	0.070 (1.8)	N/A	N/A
289041	HVLP	General Metal	0.020–0.070 (0.5–1.8)	17 (0.12, 1.2)	29 (0.20, 2.0)
289042	Compliant	General Metal	0.020–0.070 (0.5–1.8)	29 (0.20, 2.0)	33 (0.23, 2.3)
288861	Conventional	High Wear	0.059 (1.5)	N/A	N/A
289049	Conventional	High Wear	0.070–0.086 (1.8–2.2)	N/A	N/A
289115	HVLP	High Wear	0.059 (1.5)	18 (0.12, 1.2)	28 (0.19, 1.9)
289325	HVLP	High Wear	0.070 (1.8)	18 (0.12, 1.2)	27 (0.19, 1.9)
289050	Compliant	High Wear	0.059 (1.5)	28 (0.19, 1.9)	31 (0.21, 2.1)
289327	Compliant	High Wear	0.070 (1.8)	29 (0.20, 2.0)	32 (0.22, 2.2)
288862	Conventional	Wood	0.030–0.040 (0.8–1.0)	N/A	N/A
288864	HVLP	Wood	0.030–0.040 (0.8–1.0)	24 (0.17, 1.7)	26 (0.18, 1.8)
288863	Compliant	Wood	0.030–0.040 (0.8–1.0)	27 (0.19, 1.9)	42 (0.29, 2.9)

Air Flow

See the chart to determine air consumption. Add the air consumption values shown for the atomizing air and fan air pressures to get the total air consumption. For example, air cap 24B544 with 20 psi atomizing air pressure uses 3 scfm atomizing air. A 30 psi fan inlet pressure adds 5 scfm fan air for a total of 8 scfm air consumption.

Air cap	Atomizing Air		Fan Air	
	Manifold Inlet Pressure psi (MPa, bar)	Air Flow SCFM	Manifold Inlet Pressure psi (MPa, bar)	Air Flow SCFM
289773	10 (0.07, 0.7)	2	10 (0.07, 0.7)	2
	20 (0.14, 1.4)	3	20 (0.14, 1.4)	4
	30 (0.21, 2.1)	5	30 (0.21, 2.1)	5
	40 (0.28, 2.8)	7	40 (0.28, 2.8)	7
	50 (0.34, 3.4)	8	50 (0.34, 3.4)	9
289041	10 (0.07, 0.7)	3	10 (0.07, 0.7)	4
	20 (0.14, 1.4)	7	20 (0.14, 1.4)	7
	30 (0.21, 2.1)	10	30 (0.21, 2.1)	11
	40 (0.28, 2.8)	13	40 (0.28, 2.8)	14
	50 (0.34, 3.4)	17	50 (0.34, 3.4)	18
	17* (0.12, 1.2)	6	29* (0.20, 2.0)	10
288861	10 (0.07, 0.7)	2	10 (0.07, 0.7)	2
	20 (0.14, 1.4)	4	20 (0.14, 1.4)	5
	30 (0.21, 2.1)	6	30 (0.21, 2.1)	7
	40 (0.28, 2.8)	8	40 (0.28, 2.8)	10
	50 (0.34, 3.4)	11	50 (0.34, 3.4)	12
289115	10 (0.07, 0.7)	3	10 (0.07, 0.7)	4
	20 (0.14, 1.4)	7	20 (0.14, 1.4)	7
	30 (0.21, 2.1)	10	30 (0.21, 2.1)	11
	40 (0.28, 2.8)	14	40 (0.28, 2.8)	15
	50 (0.34, 3.4)	17	50 (0.34, 3.4)	19
	18* (0.12, 1.2)	6	28* (0.19, 1.9)	10
289050	10 (0.07, 0.7)	1	10 (0.07, 0.7)	2
	20 (0.14, 1.4)	3	20 (0.14, 1.4)	4
	30 (0.21, 2.1)	4	30 (0.21, 2.1)	6
	40 (0.28, 2.8)	5	40 (0.28, 2.8)	8
	50 (0.34, 3.4)	7	50 (0.34, 3.4)	10
	28* (0.19, 1.9)	4	31* (0.21, 2.1)	6
288862	10 (0.07, 0.7)	2	5 (0.035, 0.35)	1
	20 (0.14, 1.4)	4	10 (0.07, 0.7)	3
	30 (0.21, 2.1)	6	15 (0.10, 1.0)	4
	40 (0.28, 2.8)	7	20 (0.14, 1.4)	5
	50 (0.34, 3.4)	9	25 (0.17, 1.7)	7

Air cap	Atomizing Air		Fan Air	
	Manifold Inlet Pressure psi (MPa, bar)	Air Flow SCFM	Manifold Inlet Pressure psi (MPa, bar)	Air Flow SCFM
288863	10 (0.07, 0.7)	2	10 (0.07, 0.7)	3
	20 (0.14, 1.4)	4	20 (0.14, 1.4)	5
	30 (0.21, 2.1)	5	30 (0.21, 2.1)	8
	40 (0.28, 2.8)	7	40 (0.28, 2.8)	11
	50 (0.34, 3.4)	9	50 (0.34, 3.4)	13
	27* (0.19, 1.9)	5	42* (0.29, 2.9)	11
289784	10 (0.07, 0.7)	2	10 (0.07, 0.7)	2
	20 (0.14, 1.4)	4	20 (0.14, 1.4)	4
	30 (0.21, 2.1)	6	30 (0.21, 2.1)	5
	40 (0.28, 2.8)	8	40 (0.28, 2.8)	7
	50 (0.34, 3.4)	10	50 (0.34, 3.4)	9
289042	10 (0.07, 0.7)	2	10 (0.07, 0.7)	2
	20 (0.14, 1.4)	4	20 (0.14, 1.4)	4
	30 (0.21, 2.1)	6	30 (0.21, 2.1)	6
	40 (0.28, 2.8)	8	40 (0.28, 2.8)	8
	50 (0.34, 3.4)	10	50 (0.34, 3.4)	10
	29* (0.20, 2.0)	6	33* (0.23, 2.3)	7
289049	10 (0.07, 0.7)	1	10 (0.07, 0.7)	2
	20 (0.14, 1.4)	3	20 (0.14, 1.4)	4
	30 (0.21, 2.1)	4	30 (0.21, 2.1)	7
	40 (0.28, 2.8)	6	40 (0.28, 2.8)	9
	50 (0.34, 3.4)	7	50 (0.34, 3.4)	11
289325	10 (0.07, 0.7)	4	10 (0.07, 0.7)	4
	20 (0.14, 1.4)	7	20 (0.14, 1.4)	7
	30 (0.21, 2.1)	11	30 (0.21, 2.1)	11
	40 (0.28, 2.8)	14	40 (0.28, 2.8)	14
	50 (0.34, 3.4)	18	50 (0.34, 3.4)	18
	18* (0.12, 1.2)	6	27* (0.19, 1.9)	10
289327	10 (0.07, 0.7)	2	10 (0.07, 0.7)	2
	20 (0.14, 1.4)	4	20 (0.14, 1.4)	4
	30 (0.21, 2.1)	6	30 (0.21, 2.1)	6
	40 (0.28, 2.8)	7	40 (0.28, 2.8)	8
	50 (0.34, 3.4)	9	50 (0.34, 3.4)	10
	29* (0.20, 2.0)	5	32* (0.22, 2.2)	7
288864	10 (0.07, 0.7)	4	10 (0.07, 0.7)	3
	20 (0.14, 1.4)	7	20 (0.14, 1.4)	6
	30 (0.21, 2.1)	11	30 (0.21, 2.1)	10
	40 (0.28, 2.8)	14	40 (0.28, 2.8)	13
	50 (0.34, 3.4)	18	50 (0.34, 3.4)	16
	24* (0.17, 1.7)	9	26* (0.18, 1.8)	8

* Maximum HVLP/Compliant inlet manifold pressure.

Installation

The Automatic AirPro spray gun can spray most coatings or finishes currently being used for automotive, industrial, aerospace, marine, wood, plastic and architectural applications, while easily operating from paint delivery systems, such as pressure pots or remote pumps for production line operation.

The air regulator must have a minimum air flow capacity of 30 scfm at 100 psi (0.7 MPa, 7.0 bar) air pressure.

Ventilate Spray Booth

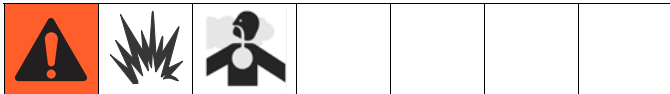

- Check and follow all national, state, and local codes regarding air exhaust velocity requirements.
- Check and follow all local safety and fire codes.

Configure Gun and Manifold

The gun is supplied with an internal fluid plug and seals (19, 20, 21). To use the gun in a circulating system, remove the internal plug. In a non-circulating system, leave the plug in place to minimize flush time.

Circulating System

1. Apply anti-seize lubricant to the threads and mating faces of the manifold (101) and the elbows (107), supplied unassembled.
2. Install the elbows (107) in both fluid ports of the manifold (101).
3. Connect the fluid supply line to one elbow and the fluid return line to the other. The manifold fluid ports are reversible.

4. Install the gun on the manifold, using the four screws (13). Start the threads of all four screws. Tighten the front two screws first, and then tighten the back two. Torque all four screws evenly to 65 in-lb (7.3 N•m).

Non-circulating System

1. See FIG. 1. Apply anti-seize lubricant to the threads and mating faces of the manifold (101), plug (109), and elbow (107), supplied unassembled.
2. Install an elbow (107) in one fluid port of the manifold (101), and a plug (109) in the other port.
3. Install the internal plug (19) in the gun fluid port on the same side as the manifold plug.
4. Connect the fluid supply line to the fluid inlet elbow (107).
5. Install the gun on the manifold, using the four screws supplied. Start the threads of all four screws. Tighten the front two screws first, and then tighten the back two. Torque all four screws evenly to 65 in-lb (7.3 N•m).

① Remove when used in circulating systems.

② Replace with elbow (107) when used in circulating systems.

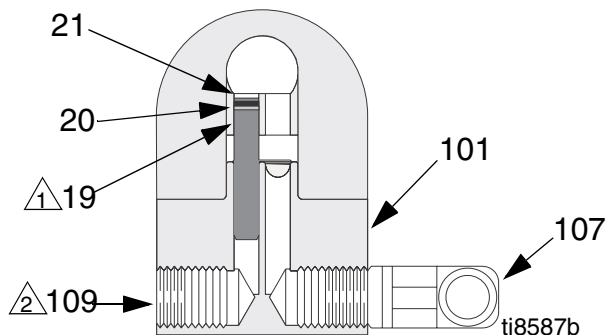

FIG. 1: Non-Circulating Setup Shown (cutaway view)

Install Air Fittings

1. Install the supplied 1/4 in. tube fitting into the cylinder (CYL) air port.
2. Install 3/8 in. tube fittings into the atomization (ATOM) air port and the fan (FAN) air port.

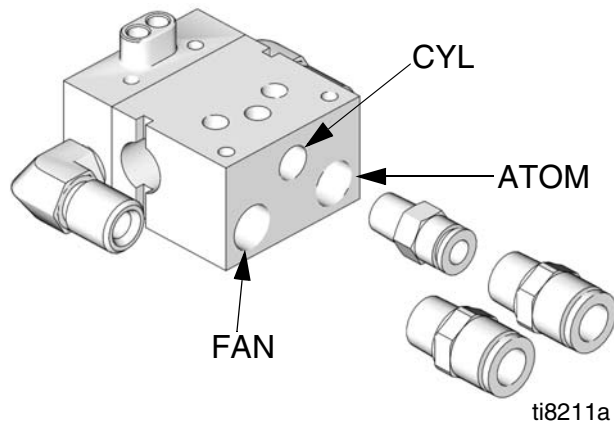
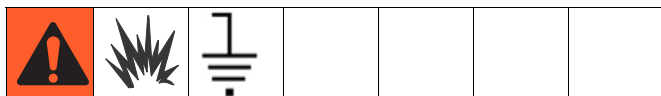

FIG. 2: Air Fittings

Ground System



The following grounding instructions are minimum requirements for a system. Your system may include other equipment or objects that must be grounded. Check your local electrical code for detailed grounding instructions for your area and type of equipment. Your system must be connected to a true earth ground.

Ground Pump/Fluid Supply

Ground the pump by connecting a ground wire and clamp between the fluid supply and a true earth ground as instructed in your separate pump instruction manual.

Ground Air Compressors and Hydraulic Power Supplies

Ground the air compressors and hydraulic power supplies according to the manufacturer recommendations.

Ground Spray Gun

Ground the spray gun by mounting the manifold to a properly grounded reciprocator, robot, or stationary mount. Check the electrical resistance between the manifold and a true earth ground. The resistance must be less than 1 megohm.

Ground Fluid Supply Container

Ground the fluid supply container according to local code.

Ground Object Being Sprayed

Ground the object that is being sprayed according to local code.

Ground Solvent Pails

Ground all solvent pails that are used when flushing according to local code. Use only metal pails, which are conductive. Do not place the pail on a non-conductive surface, such as paper or cardboard, which interrupts the grounding continuity.

Mount Gun

Reciprocating Arm Rod Mount

To mount the gun on a reciprocating arm rod [0.5 in. (13 mm) diameter maximum]:

1. Insert the mounting bar (A) through the hole in the manifold as shown in FIG. 3.

NOTE: Use the 1/8 in. alignment pin (P) to assist in orienting the gun.

2. Secure the gun to the bar by tightening the mounting screw (B).

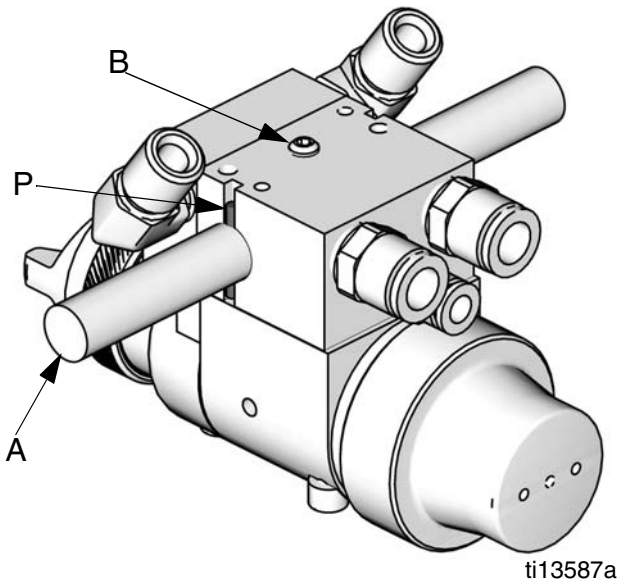

FIG. 3: Reciprocating Arm Mount

Stationary Support

To mount the gun on a stationary support (refer to FIG. 4 and to the correct mounting hole layout for your manifold, pages 38-42):

1. Align the manifold with the alignment pins. Locate alignment pins and holes per the mounting hole layout.
2. Secure the gun to the support with two M5 x 0.8 capscrews (C). The screws must be long enough to engage the threaded holes in the gun manifold to a depth of 1/4 in. (6 mm).

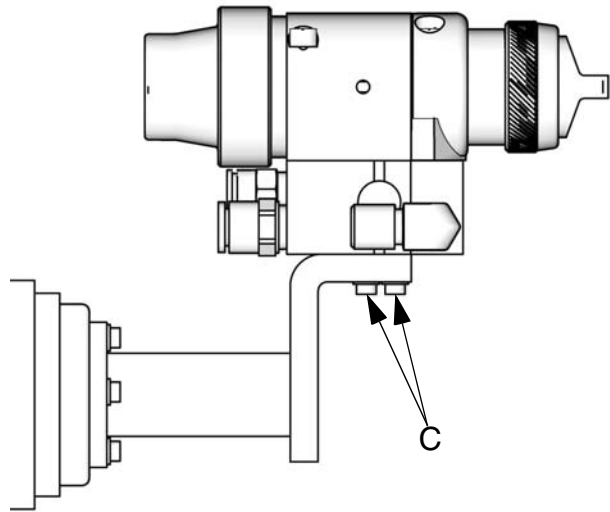

FIG. 4: Stationary Support Mount

Retrofit Adapter Plate

The retrofit adapter plate enables the manifold to be attached to a variety of bolt patterns.

To mount the gun using the retrofit adapter plate (Kit 288197; See **Accessories**, page 34):

1. Mount adapter plate to manifold using the three screws provided with the kit. (See FIG. 5 and the mounting hole layout on page 42.)
2. Bolt plate to mounting surface using four M5 x 0.8 capscrews. Refer to the correct mounting hole layout for your manifold, pages 38-41.

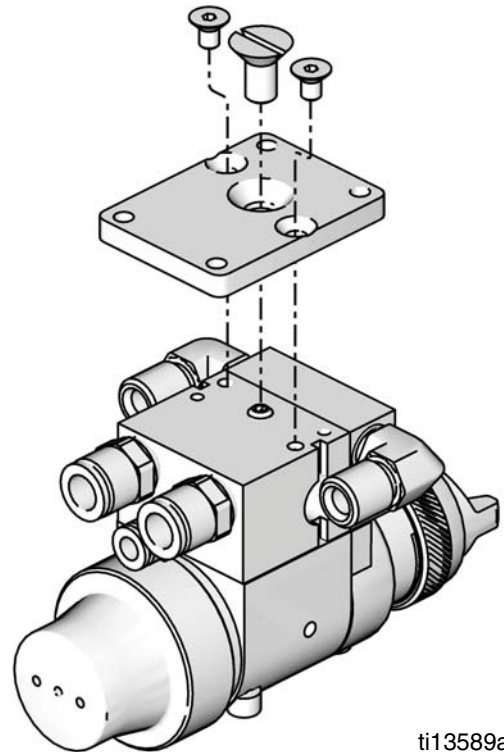

ti13589a

FIG. 5: Retrofit Adapter Plate Mount

Setup

Connect Air Line

NOTE:

- You must install an air pressure regulator (F) on each gun air line to control air pressure to the gun. See FIG. 6.
 - If your regulated air source does not have a filter, install an air filter (G) on each air line to ensure a dry, clean air supply to the gun. Dirt and moisture can ruin the appearance of your finished workpiece. See FIG. 6.
 - Install a bleed type air shutoff valve (E) on each gun air supply line, downstream of the gun air regulator, to shut off air to the gun.
1. For manifolds with a separate ATOM and FAN port, the gun cylinder, fan, and atomization air must be supplied and regulated separately. For the manual fan valve manifold, only one supply line is required for both atomization and fan air.

NOTE: The gun atomizing and fan air inlets are 3/8 in. O.D. tubing. The cylinder air inlet accepts 1/4 in. (6.3 mm) O.D. tubing. Use 3/8 in. (9.5 mm) O.D. tubing for fan and atomization air to minimize excessive pressure drop in the hoses.

2. Connect each air hose (D) to a regulated air supply line (H).

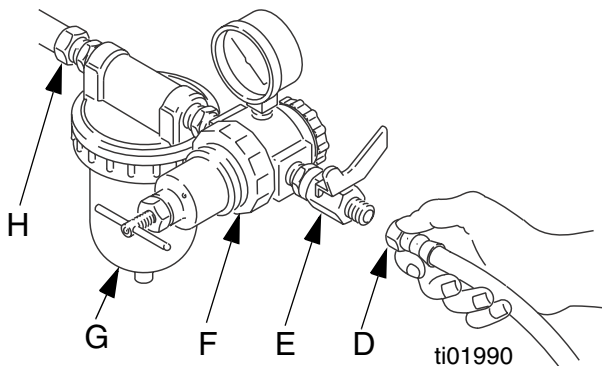

FIG. 6: Connect Air Line

Connect Fluid Hose

NOTE:

- Before connecting the fluid line, blow it out with air and flush it with solvent. Use solvent that is compatible with the fluid to be sprayed.
 - Install a fluid regulator (L) on the fluid line to control fluid pressure to the gun.
 - Install a fluid shutoff valve (M) to shut off the fluid supply to the gun.
 - Filter the fluid line of coarse particles and sediment to avoid clogging the fluid nozzle and causing finishing defects. Inline fluid filter 24B707 is available. See **Accessories**, page 34.
1. Connect the fluid supply hose (J) to the gun fluid inlet (S), 1/4 npsm thread. See FIG. 8.
 2. Connect the other end of the fluid hose (J) to a regulated fluid supply outlet (M).
 3. **In a circulating system**, connect a grounded fluid return hose to the gun fluid outlet (T). See FIG. 8.

In a non-circulating system, remove the gun fluid outlet fitting (T) and plug the outlet port with the pipe plug supplied. See FIG. 8.

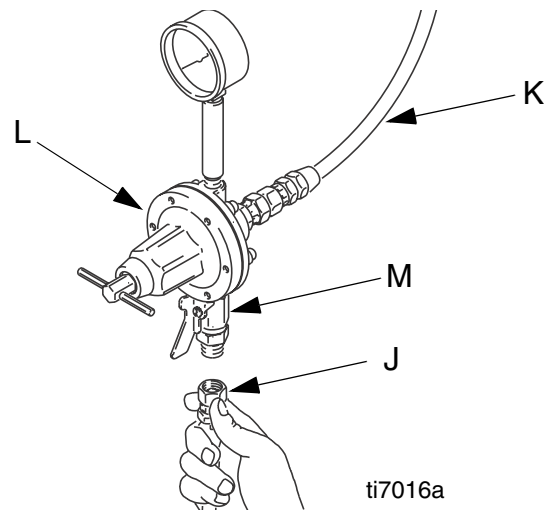
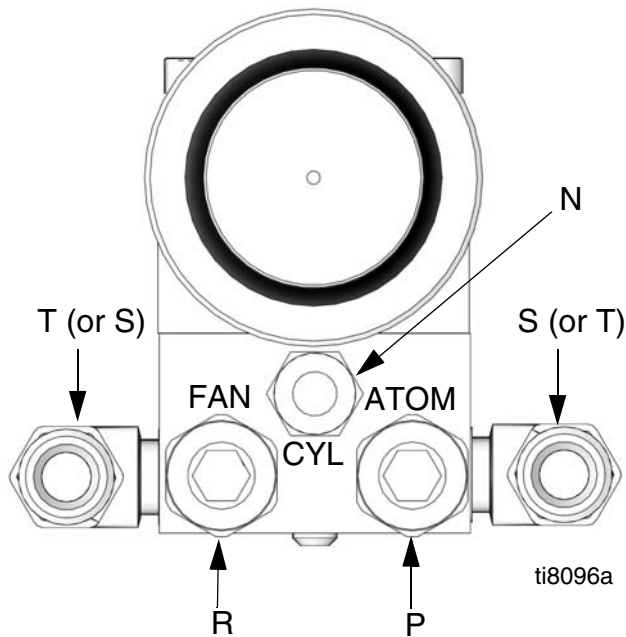

FIG. 7: Connect Fluid Hose.

KEY

- N Cylinder Air Inlet: accepts 1/4 in. (6.3 mm) O.D. tubing
- P Atomization Air Inlet: 3/8 in. (9.5 mm) O.D. tubing
- R Fan Air Inlet: 3/8 in. (9.5 mm) O.D. tubing
- S Fluid Inlet: 1/4 npsm
- T Fluid Outlet (circulating gun only): 1/4 npsm

Side Mounted Manifold Ports



Bottom Mounted Manifold Ports

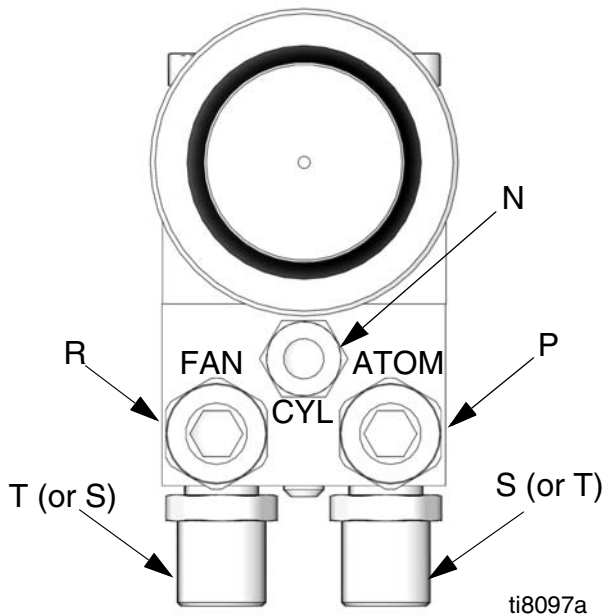

FIG. 8: Manifold Ports

Flush Spray Gun



Before running any paint through the spray gun:

1. Flush the gun with a solvent that is compatible with the fluid to be sprayed, using the lowest possible fluid pressure and a grounded metal container.
2. Perform **Pressure Relief Procedure**; see page 18.

Position Air Cap

Air caps are factory-set with the alignment pin (A) set to a vertical spray pattern. To change the air cap to a horizontal spray pattern, use a 1/6 in. hex wrench to unscrew the alignment pin (A) and relocate it to the horizontal spray pattern hole. When relocating the pin use low strength thread locker. Torque to 1.5-2.5 in-lb (0.2-0.3 N·m). **Do not overtighten.** Refer to FIG. 9.

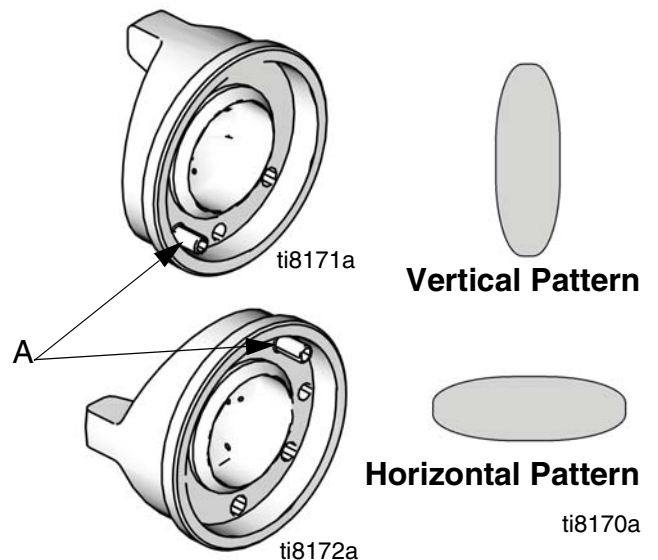

FIG. 9: Position Air Cap

Adjust Spray Pattern



Do not exceed 100 psi (0.7 MPa, 7 bar) maximum fluid and air pressure. Higher pressures can cause parts to rupture and result in serious injury.

Use the fluid pressure regulator to adjust the spray gun fluid flow. Some models are equipped with a fluid control knob to make precise fluid flow adjustments.

NOTICE

Use caution when operating the fluid control knob near the closed position. The plastic needle tip may be damaged if forced too hard against the nozzle seat by the fluid control knob.

Follow these steps to establish the correct fluid flow and air flow:

1. To achieve desired flow, adjust the fluid flow using the fluid pressure regulator (L) installed in the gun fluid line. Typical industrial flow rates will vary with regulator pressures from 5 to 30 psi (34 to 210 kPa, 0.3 to 2.1 bar). If the fluid pressure is too low at the desired flow rate, install a smaller nozzle. If the fluid pressure is too high, install a larger nozzle.

For spray guns equipped with the fluid control knob, you can make flow rate changes at the spray gun. Rotate the fluid control knob clockwise to reduce the flow.

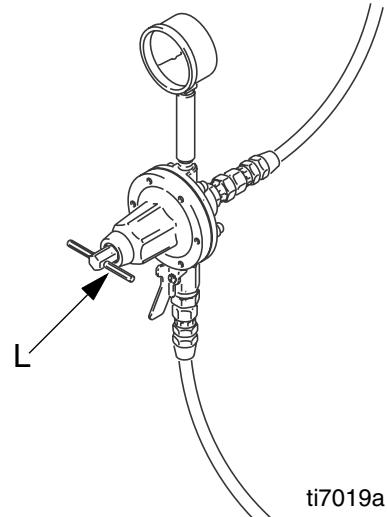

FIG. 10: Fluid Pressure Regulator

NOTE: A larger fluid nozzle at a reduced fluid pressure will maintain the same flow rate, but the fluid stream (velocity) will slow down. When air is applied, the lower velocity allows the air to act on the fluid longer, which improves atomization.

2. Using the air pressure regulator (F), set the fan and atomizing air supply pressure per Table 1. Use these suggested settings as a starting point.

Table 1: Suggested Starting Settings

Spray Gun	Fan Air (psi)	Atomization Air (psi)
Conventional	35	35
HVLP	25	25
Compliant	25	25

NOTE: HVLP and Compliant Gun Limits

HVLP Guns: local laws may limit the maximum pressure to 10 psi (70 kPa, 0.7 bar) at the air cap for compliance. See the table on page 7 for maximum HVLP/Compliant manifold inlet pressures. To measure pressure at the air cap, use the appropriate HVLP Pressure Verification Kit. See **Accessories**, page 34.

Compliant Guns: See the table on page 7 for maximum HVLP/Compliant manifold inlet pressures.

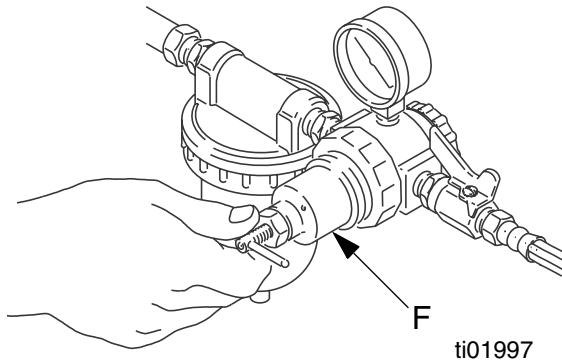

FIG. 11: Air Pressure Regulator

3. Test the spray pattern atomization while keeping the gun a consistent distance, about 6 to 8 inches (150 to 200 mm), from the test piece.

Check the atomization quality. Increase the gun atomizing air supply pressure with the air pressure regulator in 5 psi (34 kPa, 0.3 bar) increments until you obtain the desired atomization.

NOTE: For the best transfer efficiency, use the lowest setting needed to achieve desired finish quality.

4. If the spray pattern is too wide or split, reduce the fan air pressure (or slightly close the fan adjustment valve on manifold 288223).

To further control the spray pattern of *air-spray guns only*, use an alternate air cap. For a list of available air caps, refer to **Accessories**, page 34.

NOTE: Reducing the fan air pressure to 0 psi (or fully closing the fan adjustment valve) will produce a round pattern.

Operation

Pressure Relief Procedure

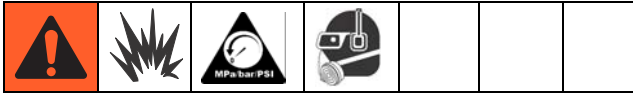

1. Turn off all bleed type air valves and all other air and fluid supplies to the gun.
2. Trigger the gun into a grounded metal waste container to relieve air and fluid pressure.

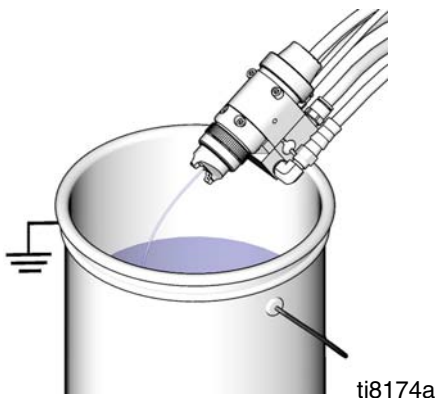

FIG. 12: Pressure Relief

Apply Fluid

The spray gun has a built-in lead and lag operation. When triggered, the gun begins emitting air before the fluid is discharged. When the trigger actuation air is stopped, the fluid stops before the air flow stops. This helps ensure that the spray is atomized and prevents fluid buildup on the air cap and tip.

Adjust the system control device, if it is automatic, so the gun starts spraying just before meeting the part and stops as soon as the part has passed.

To achieve best results when applying fluid:

- Keep gun perpendicular and 6 to 8 in. (150 to 200 mm) from object being sprayed.
- Use smooth, parallel strokes across surface to be sprayed with 50% overlap.

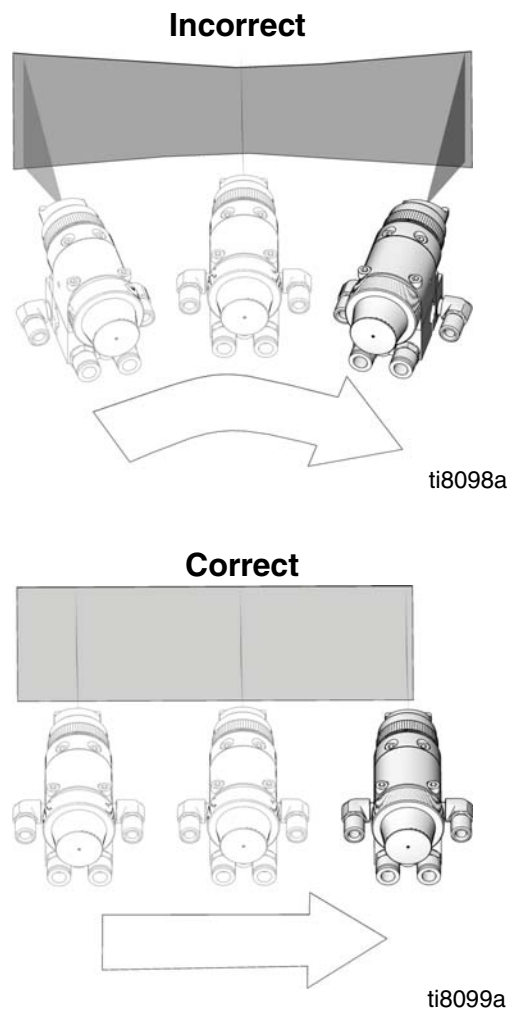
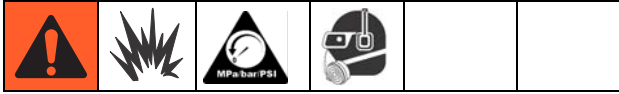

FIG. 13: Correct Spray Method

Daily Gun Care



NOTICE

Methylene chloride with formic or propionic acid is not recommended as a flushing or cleaning solvent with this gun as it will damage aluminum and nylon components.

NOTICE

Solvent left in gun air passages could result in a poor quality paint finish. Do not use any cleaning method which may allow solvent into the gun air passages.

Do not point the gun up while cleaning it.

Do not wipe the gun with a cloth soaked in solvent; wring out the excess.



ti8100a



ti4827a

Do not immerse the gun in solvent.

Do not use metal tools to clean the air cap holes as this may scratch them; scratches can distort the spray pattern.



ti8101a



ti8175a

General System Maintenance

- Perform **Pressure Relief Procedure**, page 18.
- Clean the fluid and air line filters daily.
- Check for any fluid leakage from the gun and fluid hoses. Tighten fittings or replace equipment as needed.
- Flush the gun before changing colors and whenever you are done operating the gun.

Clean and Flush Gun

1. Perform **Pressure Relief Procedure**, page 18.
2. Shut off the gun fan and atomizing air.
3. Supply a compatible solvent to the gun fluid inlet.
4. Point the gun down into a grounded metal container, and flush the gun with solvent until all traces of paint are removed from the gun passages.
5. Perform **Pressure Relief Procedure**, page 18.
6. Disconnect the solvent supply.
7. Remove the air cap retaining ring and air cap. Remove the nozzle, if necessary.

NOTICE

Trigger the gun or remove the piston cap if you remove the nozzle for cleaning. This keeps the needle seat away from the nozzle seating surface and prevents the seat from being damaged.

8. Clean the air cap retaining ring, air cap, and fluid nozzle with solvent.

9. Dip the end of a soft-bristle brush into a compatible solvent. Do not continuously soak the brush's bristles with solvent and do not use a wire brush.



FIG. 14: Use solvent-dipped soft-bristle brush

10. With the gun pointed down, clean the front of the gun, using the soft-bristle brush and solvent.
11. Scrub the air cap retaining ring, air cap, and fluid nozzle with the soft-bristle brush (see FIG. 15). To clean out air cap holes, use a soft implement, such as a toothpick, to avoid damaging critical surfaces. Clean the air cap and fluid nozzle daily, minimum. Some applications require more frequent cleaning.

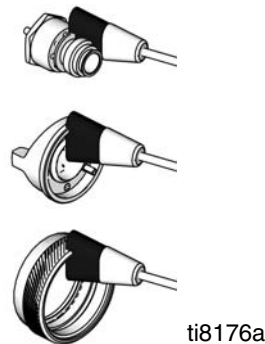

FIG. 15: Clean air cap, ring and fluid nozzle

12. Install the air cap retaining ring and air cap.
13. Dampen a soft cloth with solvent and wring out the excess. Point the gun down and wipe off the outside of the gun.

Troubleshooting



Some improper patterns are caused by the improper balance between air and fluid. Refer to **Spray Pattern Troubleshooting**, page 22.

NOTE: Check all possible remedies in the troubleshooting charts before disassembling the gun.

General Troubleshooting

Problem	Cause	Solution
Fluid leakage through venting holes.	Worn packing (17) or needle (5).	Replace packing or needle.
Air leakage through venting hole.	Worn o-ring (9) or gasket (15).	Check and replace parts as needed.
Air leakage from back of gun.	Worn o-rings (8, 9).	Replace o-rings.
Air does not trigger.	Piston stem is disconnected from main body of piston assembly (3). Cylinder air pressure is too low.	Replace piston assembly. Increase cylinder air pressure to 50 psi.
Air does not shut off.	Piston assembly not seating properly. Broken return spring (7). Swollen o-ring (8). Worn piston stem o-rings (10, 11). Bottom gasket (12) failed.	Clean/service piston assembly. Replace worn or swollen o-rings. Replace return spring. Replace o-rings. Replace o-rings. Replace gasket.
Fluid leakage from front of gun.	Fluid needle tip (5a) is dirty, worn, or damaged. Dirty or worn nozzle (23).	Clean or replace fluid needle tip or entire needle (5). Clean or replace nozzle.
Fluid is present at air cap holes.	Nozzle (23) is insufficiently tightened or sealing o-ring (36) is damaged.	Tighten or replace o-ring.

Problem	Cause	Solution
Fluid needle will not trigger.	Loose or missing fluid needle stop (29) or setscrew (30). Air leaking around piston (3). Swollen piston o-ring (8). Insufficient air pressure on trigger. Plug (19) is in incorrect fluid port.	Replace stop or tighten setscrew. Replace o-ring (8) or piston. Replace o-ring. Do not immerse piston in solvent. Increase air pressure or clean air line. Move plug to fluid port consistent with manifold plumbing, unless you are using gun in a circulating system. If you are, all fluid ports in gun and on manifold should be open.
Fluid does not shut off.	Worn o-ring (11) or (9). Piston cap (4) not fully tightened. Spring (6) not in place. Swollen piston o-ring (8).	Replace o-ring. Tighten piston cap until it bottoms out. Check spring position. Replace o-ring. Do not immerse piston in solvent.

Spray Pattern Troubleshooting

Problem	Cause	Solution
Fluid flow is fluttering while spraying.	Fluid nozzle is not tight enough. O-ring (36) is missing or damaged. Fluid filter is clogged.	Tighten fluid nozzle to 60 in-lb (6.8 N•m). Replace o-ring. Check fluid filter.
Fluid flow fades while spraying high viscosity fluids.	Fluid pressure is too low, causing fluid flow to reduce when gun is elevated.	Raise fluid pressure at source or use a smaller fluid nozzle.
Pattern becomes off-set or heavy on ends.	Air cap horn holes plugged or damaged.	Clean air cap horn holes with non-metallic item such as a toothpick, or replace air cap.
Gun fluid pressure is too high with gun triggered.	Using needle/nozzle kit with too small orifice.	Use needle/nozzle kit with larger orifice.
Fluid system will not operate at low enough fluid pressure [below 10 psi (70 kPa, 0.7 bar)].	There is no fluid regulator, or air regulator on pressure pot is not sensitive enough at low pressures.	Add low pressure fluid regulator, or add more sensitive low pressure air regulator on pressure pot.

Service



NOTE: Air Section Repair Kit 288171 and Fluid Section Repair Kit 24B675 are available for purchase separately. Numbers in parenthesis in the text refer to the reference numbers in the figures and in the parts list.

Disassembly

1. Perform **Pressure Relief Procedure**, page 18.
2. Unscrew the four screws (13) and remove the gun from the manifold.
3. Remove the air cap retainer (25) and air cap (24).

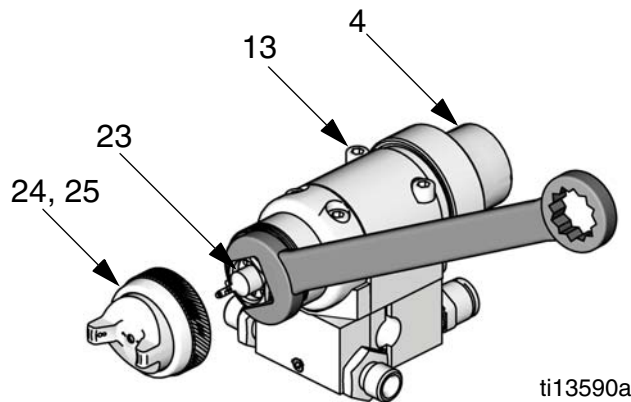

FIG. 16

4. Remove the piston cap (4) from the piston housing (1). Remove the springs (6, 7).
5. Using a 1/16 in. hex wrench loosen the fluid needle set screw (30). Remove the needle stop (29).
6. Pull the fluid needle (5) out of the back of the gun.

7. Check the fluid needle (5) for damage or excessive wear. Replace the needle tip (5a) or the entire needle if necessary.
8. Remove nozzle (23). Check nozzle and o-ring (36) for damage.

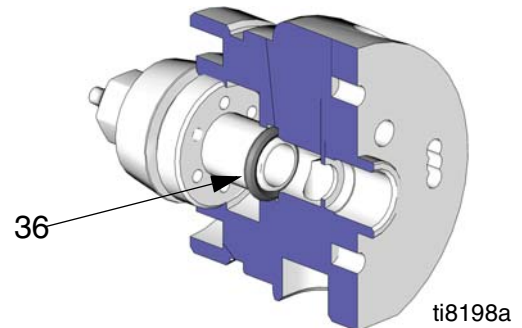

FIG. 17

9. Remove the piston. Using a pliers, pull the piston (3) out of the piston housing (1).
10. Unscrew the two screws (14) and separate the fluid housing (2) and the piston housing (1). Remove gasket (12) only if it needs to be replaced.

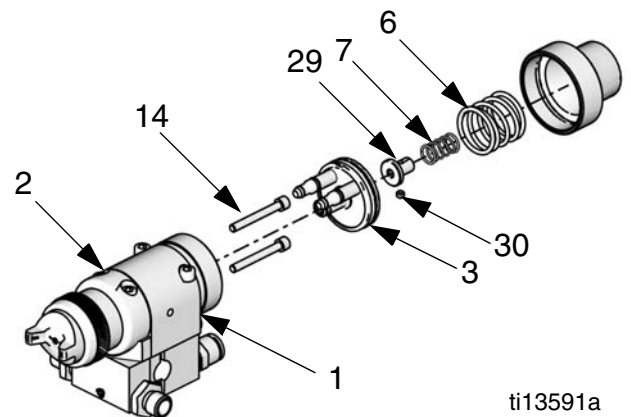

FIG. 18

11. Remove the packing nut (16) with a wrench.
12. Remove the fluid packing (17) from the nut (16). Discard the old fluid packing.

13. Remove all o-rings from the piston (3) and stems (T). Check that the stems are solidly in place. If they are loose, replace the entire piston assembly (3).

o-ring (21) and backup (20) from the plug. See FIG. 21.

14. Perform the following applicable step:

b. *Circulating guns:* Remove the gasket (22) from the fluid housing (2). See FIG. 21.

a. *Non-circulating guns:* Remove the fluid outlet port plug (19), and gasket (22) from the fluid housing (2). Remove the

15. Clean all parts and replace any worn parts. When assembling, lubricate the threads with anti-seize lubricant.

Cutaway View:
Part No. 24A749 Gun Shown

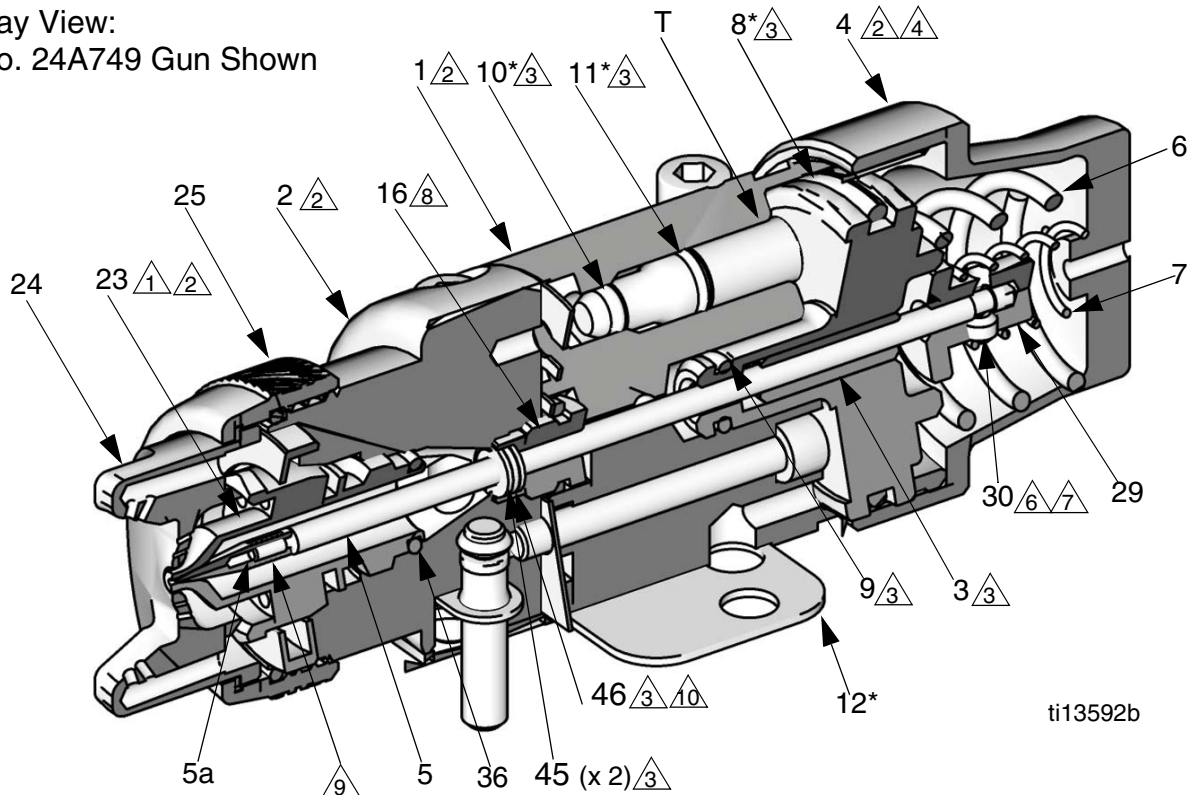

ti13592b

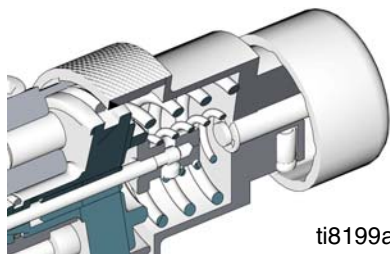

Alternate Fluid Control Shown

SERVICE NOTES:

- △1 Torque to 35-45 in-lb (4.0-5.1 N•m).
- △2 Lubricate threads with anti-seize lubricant.
- △3 Lubricate with light-weight oil.
- △4 Tighten cap (4) until it bottoms out.
- △6 Apply semi-permanent anaerobic sealant.
- △7 Torque to 6.5-7.5 in-lb (0.73-0.85 N•m).
- △8 Torque to 95-105 in-lb (10.7-11.8 N•m).
- △9 Apply semi-permanent anaerobic sealant to two threads at end of needle shaft.
- △10 Step in spacer (46) must face into packing nut.

FIG. 19

Reassembly

1. *Non-circulating guns only:* Lubricate the backup ring (20†) and o-ring (21†) and install them on the fluid outlet port plug (19). Install the plug in the fluid outlet port of the fluid housing (2). See FIG. 21.
2. *All guns:* Reinstall the gasket (22) in the fluid housing (2).
3. Install the o-rings (8*, 9*) on the piston (3). Install the two o-rings (10*, 11*) on each of the piston stems (T). Lubricate all the o-rings, the piston, and the piston stems.
4. Remove the protective paper from the sticky side of the gasket (12*) and adhere the gasket to the bottom of the piston housing (1), making sure the three holes in the gasket are properly aligned with the matching holes in the housing.
5. Lubricate the washers (45†) and spacer (46†). Insert them into the packing nut (16) as shown in FIG. 20. The step on the spacer faces into the packing nut.

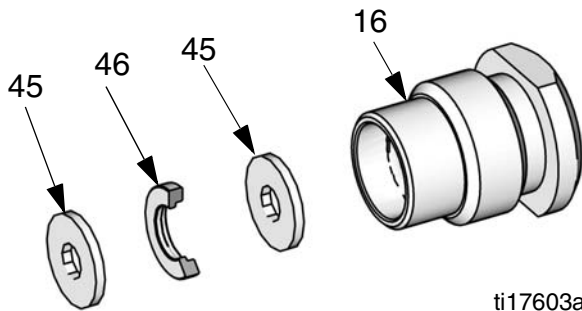

ti17603a

FIG. 20. Fluid packings

6. Insert the packing nut into the fluid housing (2) and torque to 95-105 in-lb (10.7-11.8 N•m).
7. Align the gasket (15*) as shown in the exploded view in FIG. 21. Place the gasket on the piston housing (1), then install the fluid housing (2) onto the piston housing.

Torque the two screws (14) to 35-45 in-lb (4.0-5.1 N•m).

- a. Insert the piston (3) into the piston housing (1).
 - b. Ensure nozzle sealing o-ring (36) is installed on nozzle (23).
8. To avoid galling of the fluid nozzle seat in the fluid housing, apply a thin film of lubricant to the threads. Install the nozzle into the fluid housing. Torque the nozzle securely to 35-45 in-lb (4.0-5.1 N•m).
- NOTE:** If you are replacing the needle tip (5a), apply semi-permanent anaerobic sealant to two threads at the end of the needle shaft. Assemble the needle tip to the shaft and hand tighten. Allow adequate time for the sealant to cure before installing the needle assembly into the gun.
9. Lubricate and install the needle (5) into the back of the gun assembly. Push it straight in through the piston.
 10. Install the needle stop (29) on the needle. Coat the setscrew (30) with semi-permanent anaerobic sealant and install the screw into the needle stop. Torque to 6.5-7.5 in-lb (0.73-0.85 N•m). Pull on the needle to make sure it seats fully.

11. Install the springs (6, 7).
12. Lubricate the threads of the piston housing (1). Screw the cap (4) onto the housing until it bottoms out.
13. Install the air cap (24) and air cap retainer (25).
14. Reinstall the gun on the manifold using the four screws (13). Start the threads of all four screws. Tighten the front two screws first, and then tighten the back two. Torque all four screws evenly to 65 in-lb (7.3 N•m).

Parts

Part No. 24A749 Gun Shown

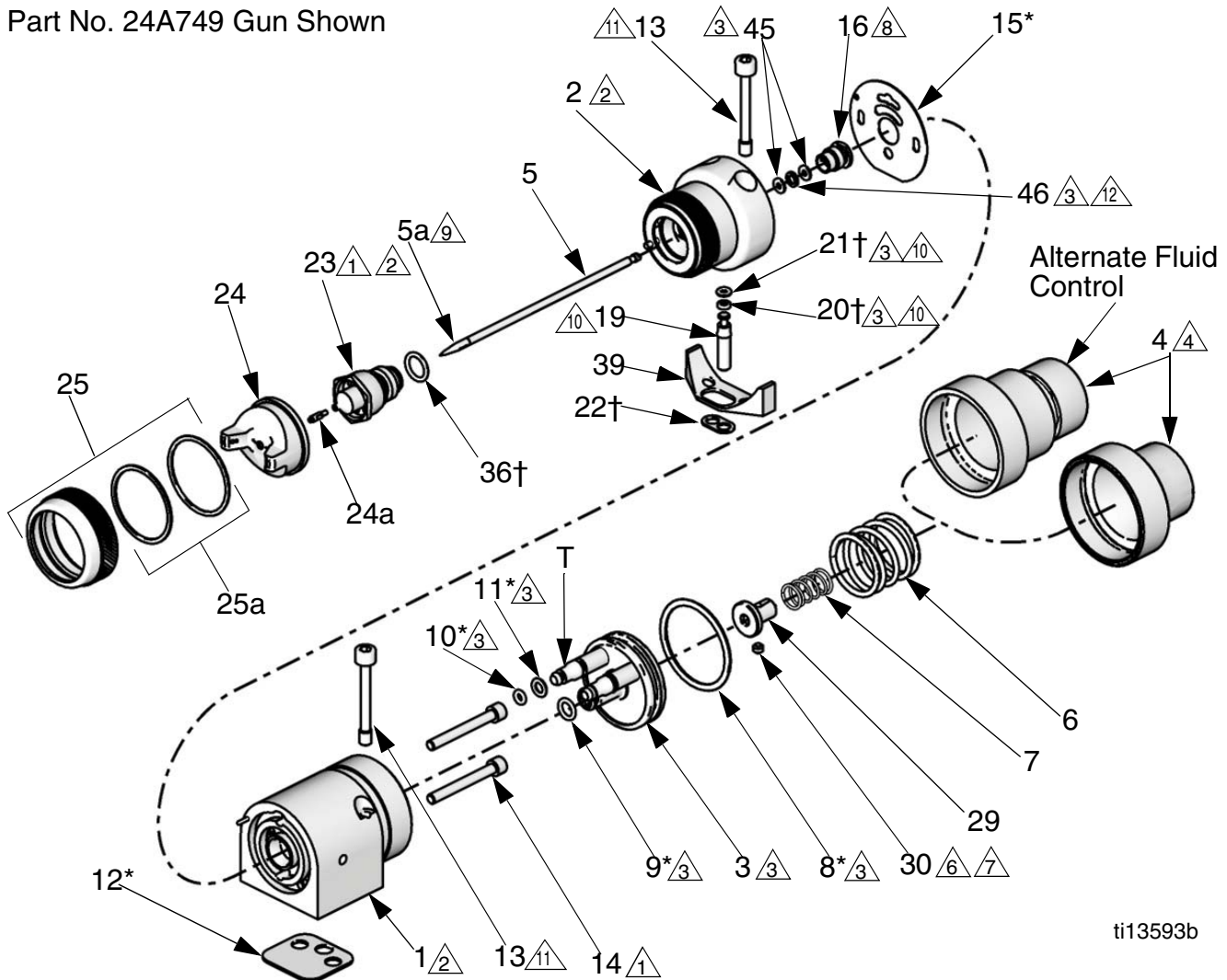

ti13593b

SERVICE NOTES:

- △1 Torque to 35-45 in-lb (4.0-5.1 N•m).
- △2 Lubricate threads with anti-seize lubricant.
- △3 Lubricate with light-weight oil.
- △4 Tighten cap (4) until it bottoms out.
- △6 Apply semi-permanent anaerobic sealant.
- △7 Torque to 6.5-7.5 in-lb (0.73-0.85 N•m).
- △8 Torque to 95-105 in-lb (10.7-11.8 N•m).
- △9 Apply semi-permanent anaerobic sealant to two threads at end of needle shaft.
- △10 Used on non-circulating guns only.
- △11 Torque to 65 in-lb (7.3 N•m).
- △12 Step in spacer (46) must face into packing nut.

FIG. 21

Ref.	Part	Description	Qty.
1	-----	HOUSING, piston	1
2	24B676	HOUSING, fluid	1
3	240895	PISTON, assembly	1
4	See pages 28-29	CAP, piston	1
5	See pages 28-29	NEEDLE, assembly	1
5a	See pages 28-29	TIP, needle	1
6	114139	SPRING, compression	1
7	114138	SPRING, compression	1
8*	115066	O-RING, fluoroelastomer	1
9*	111450	O-RING, fluoroelastomer	1
10*	111504	O-RING, fluoroelastomer	2
11*	112319	O-RING, fluoroelastomer	2
12*	114134	GASKET, polyethylene (bottom)	1
13	15H317	SCREW, mounting manifold (M5)	4
14	15H318	SCREW, SHC	2
15*	15H316	GASKET, polyethylene (front)	1
16	195222	NUT, packing	1
19	192687	PLUG, fluid	1
20†	114340	RING, back-up, PTFE	1
21†	114244	O-RING, fluoroelastomer	1

Ref.	Part	Description	Qty.
22†	192443	GASKET, fluid	2
23	See pages 28-29	NOZZLE, fluid, 0.030 in.	1
24	See pages 28-29	CAP, air	1
24a	24B546	PIN, locating, threaded; (pack of 10)	1
25	289079	RETAINER, ring, assembly	1
25a	289791	SEAL KIT, air cap (5 of each)	5
	-----	O-RING, PTFE	5
	-----	WASHER, UHMW	5
29	192452	STOP, needle	1
30	114137	SCREW, set	1
34	114141	WRENCH, hex, not shown	1
36†	111457	O-RING	1
38	-----	PIN, dowel, not shown	1
39	15H702	INSERT, plastic	1
40▲	15K759	LABEL, warning, not shown	1
45†	-----	WASHER, UHMWPE	2
46†	-----	SPACER, stainless steel	1

* Included in Air Seal Repair Kit 288171.

† Included in Fluid Seal Repair Kit 24B675.

----- Not sold separately.

▲ Replacement Warning labels, signs, tags, and cards are available at no cost.

Repair Kits

NOTE: Alternate nozzle sizes are also available. See **Accessories**, page 34.

General Metal Applications

Gun Part Number	Spray Type	Nozzle Orifice Size in. (mm)	Needle/Nozzle Kit (Includes Items 5 and 23)	Item 4 Piston Cap	Item 5 Needle Assembly (Includes Needle Tip)	Item 5a Needle Tip (Pack of 5)	Item 23 Nozzle	Item 24 Air Cap (Includes locating pin)	Air Cap (without locating pin)
24B333	Conventional	0.020 (0.5)	24B332	192453	24B331	289350	289061	24B544	289773
24A747	Conventional	0.030 (0.8)	24A687	192453	24A683	288183	289062	24B544	289773
24A748	Conventional	0.042 (1.1)	24A688	192453	24A684	288184	289063	24B544	289773
24A749	Conventional	0.055 (1.4)	24A689	192453	24A685	288185	289064	24B544	289773
24A750	Conventional	0.070 (1.8)	24A690	192453	24A685	288185	289065	24B545	289784
24B334	HVLP	0.020 (0.5)	24B332	192453	24B331	289350	289061	24B539	289041
24A754	HVLP	0.030 (0.8)	24A687	192453	24A683	288183	289062	24B539	289041
24A755	HVLP	0.042 (1.1)	24A688	192453	24A684	288184	289063	24B539	289041
24A756	HVLP	0.055 (1.4)	24A689	192453	24A685	288185	289064	24B539	289041
24A757	HVLP	0.070 (1.8)	24A690	192453	24A685	288185	289065	24B539	289041
24B335	Compliant	0.020 (0.5)	24B332	192453	24B331	289350	289061	24B540	289042
24A761	Compliant	0.030 (0.8)	24A687	192453	24A683	288183	289062	24B540	289042
24A762	Compliant	0.042 (1.1)	24A688	192453	24A684	288184	289063	24B540	289042
24A763	Compliant	0.055 (1.4)	24A689	192453	24A685	288185	289064	24B540	289042
24A764	Compliant	0.070 (1.8)	24A690	192453	24A685	288185	289065	24B540	289042
24A751★	Conventional	0.030 (0.8)	24A687	24A512	24A683	288183	289062	24B544	289773
24A752★	Conventional	0.042 (1.1)	24A688	24A512	24A684	288184	289063	24B544	289773
24A753★	Conventional	0.055 (1.4)	24A689	24A512	24A685	288185	289064	24B544	289773
24A758★	HVLP	0.030 (0.8)	24A687	24A512	24A683	288183	289062	24B539	289041
24A759★	HVLP	0.042 (1.1)	24A688	24A512	24A684	288184	289063	24B539	289041
24A760★	HVLP	0.055 (1.4)	24A689	24A512	24A685	288185	289064	24B539	289041
24A765★	Compliant	0.030 (0.8)	24A687	24A512	24A683	288183	289062	24B540	289042
24A766★	Compliant	0.042 (1.1)	24A688	24A512	24A684	288184	289063	24B540	289042
24A767★	Compliant	0.055 (1.4)	24A689	24A512	24A685	288185	289064	24B540	289042

High Wear Applications

Gun Part Number	Spray Type	Nozzle Orifice Size in. (mm)	Needle/Nozzle Kit (Includes Items 5 and 23)	Item 4 Piston Cap	Item 5 Needle Assembly (Includes Needle Tip)	Item 5a Needle Tip (Pack of 5)	Item 23 Nozzle	Item 24 Air Cap (Includes locating pin)	Air Cap (without locating pin)
24A774✘	Conventional	0.059 (1.5)	24A693	192453	24A686	N/A	289074	24B537	288861
24A775✘	Conventional	0.070 (1.8)	24A694	192453	24A686	N/A	289075	24B536	289049
24B336✘	Conventional	0.086 (2.2)	24B358	192453	24B357	N/A	289076	24B536	289049
24C316✘	Conventional	0.110 (2.8)	24C142	192453	24C319	N/A	289975	24B536	289049
24A776✘	HVLP	0.059 (1.5)	24A695	192453	24A686	N/A	289331	24B541	289115
24A777✘	HVLP	0.070 (1.8)	24A696	192453	24A686	N/A	289332	24B542	289325
24A778✘	Compliant	0.059 (1.5)	24A695	192453	24A686	N/A	289331	24B538	289050
24A779✘	Compliant	0.070 (1.8)	24A696	192453	24A686	N/A	289332	24B543	289327

Wood Applications

Gun Part Number	Spray Type	Nozzle Orifice Size in. (mm)	Needle/Nozzle Kit (Includes Items 5 and 23)	Item 4 Piston Cap	Item 5 Needle Assembly (Includes Needle Tip)	Item 5a Needle Tip (Pack of 5)	Item 23 Nozzle	Item 24 Air Cap (Includes locating pin)	Air Cap (without locating pin)
24A768	Conventional	0.030 (0.8)	24A691	192453	24A683	288183	288927	24B533	288862
24A769	Conventional	0.040 (1.0)	24A692	192453	24A684	288184	289112	24B533	288862
24A770	HVLP	0.030 (0.8)	24A691	192453	24A683	288183	288927	24B535	288864
24A771	HVLP	0.040 (1.0)	24A692	192453	24A684	288184	289112	24B535	288864
24A772	Compliant	0.030 (0.8)	24A691	192453	24A683	288183	288927	24B534	288863
24A773	Compliant	0.040 (1.0)	24A692	192453	24A684	288184	289112	24B534	288863

★ Model has Fluid Control Knob (for fine adjustment of fluid flow).

✘ Needle tip and nozzle exit constructed from tungsten carbide.

Part No. 288221

Manifold with bottom fluid ports

Ref. No.	Part No.	Description	Qty.
101	-----	MANIFOLD, bottom fluid ports	1
103	120388	FITTING, tube, air inlet; 1/4 in. OD tube x 1/8 npt(m)	1
105	114246	SCREW, set; 5/16, 0.437 in. long	1
107	166846	NIPPLE, SST; 1/4 npsm, straight pipe thread x 1/4 npt	2
108	120389	FITTING, tube, air line; 3/8 in.OD tube x 1/4 npt	2
109*	101970	PLUG, pipe, SST; 1/4-18 ptf, supplied to plug fluid outlet port in non-circulating appli- cations	1
114	120453	SCREW, SHCS, M3 x 18	1

* Not shown.

----- Not sold separately.

⚠ Apply anti-seize lubricant to threads and mating faces of manifold (101) and any fittings and/or plugs used in fluid ports.

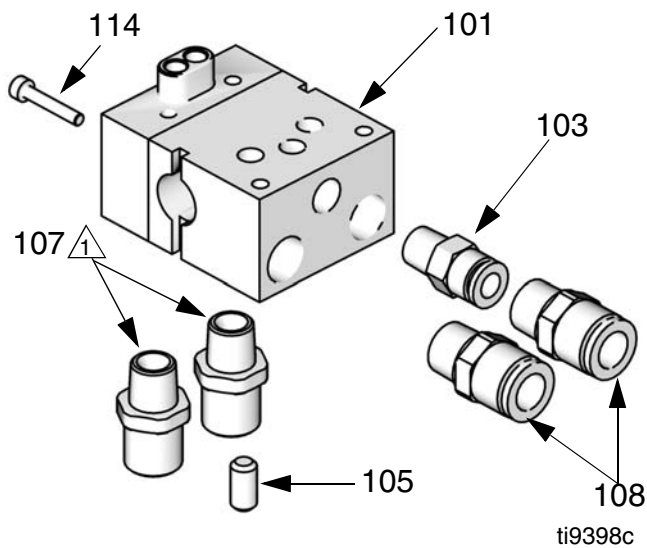

FIG. 22: Manifold with Bottom Fluid Ports

Part No. 288223

North America Low Pressure Manifold with side fluid ports and fan adjustment valve

Part No. 24C342

International Low Pressure Manifold with side fluid ports and fan adjustment valve

Ref. No.	Part No.	Description	Qty.
101	-----	MANIFOLD, fan adjustable	1
102	243949	VALVE, fan, assy.	1
103	120388⊗ 120538◆	FITTING, tube, air inlet; 1/4 in. OD tube x 1/8 npt(m) 6 mm OD tube x 1/8 npt(m)	1
104	120389⊗ 120537◆ 15D916◆*	FITTING, tube, air line; 3/8 in.OD tube x 1/4 npt 8 mm OD tube x 1/4 npt 4 mm OD tube x 1/4 npt; shipped loose	1
107	114246	SCREW, set; 5/16;0.437 in. long	1
108	114342⊗ 114247◆	ELBOW, male 1/4 - 18 npt #5JIC x 1/4-18 npt	2
109*	101970	PLUG, pipe, SST; 1/4-18 ptf, supplied to plug fluid outlet port in non-circulat- ing applications	1
114	120453	SCREW, SCHS, M3 x 18	1

* Not shown, optional size

----- Not sold separately.

⊗ Part No. 288223 only.

◆ Part No. 24C342 only.

- 1 Apply anti-seize lubricant to threads and mating faces of manifold (101) and any fittings and/or plugs used in fluid ports.
- 2 Install with valve turned fully counterclockwise to outermost position.
- 3 Torque to 125-135 in-lb (14-15 N•m).

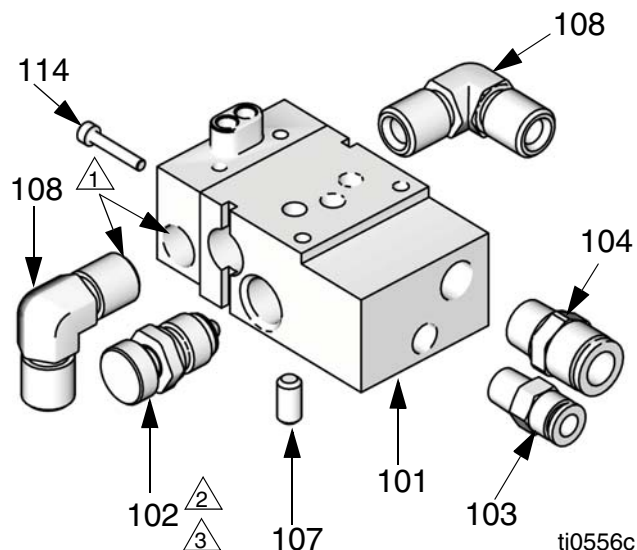

Fig. 23: Side Fluid Ports and Fan Adjustment Valve

Part No. 288217

North America Manifold with side fluid ports

Part No. 288218

International Manifold with side fluid ports

Ref. No.	Part No.	Description	Qty.
101	-----	MANIFOLD, side fluid ports	1
103	120388❖ 120538◆	FITTING, tube, air inlet 1/4 in. OD tube x 1/8 npt(m) 6 mm OD tube x 1/8 npt(m)	1
105	114246	SCREW, set; 5/16; 0.437 in. long	1
107	114342❖ 114247◆	ELBOW, male, 1/4-18 npt #5 JIC x 1/4-18 npt	2
108	120389❖ 120537◆ 15D916◆*	FITTING, tube, air line 3/8 in.OD tube x 1/4 npt 8 mm OD tube x 1/4 npt 4 mm OD tube X 1/4 npt; shipped loose	2
109*	101970	PLUG, pipe, SST; 1/4-18 ptf, supplied to plug fluid outlet port in non-circulating applications	1
114	120453	SCREW, SHCS, M3 x 18	1

* Not shown, optional size.

----- Not sold separately.

❖ Part No. 288217 only.

◆ Part No. 288218 only.

△ Apply anti-seize lubricant to threads and mating faces of manifold (101) and any fittings and/or plugs used in fluid ports.

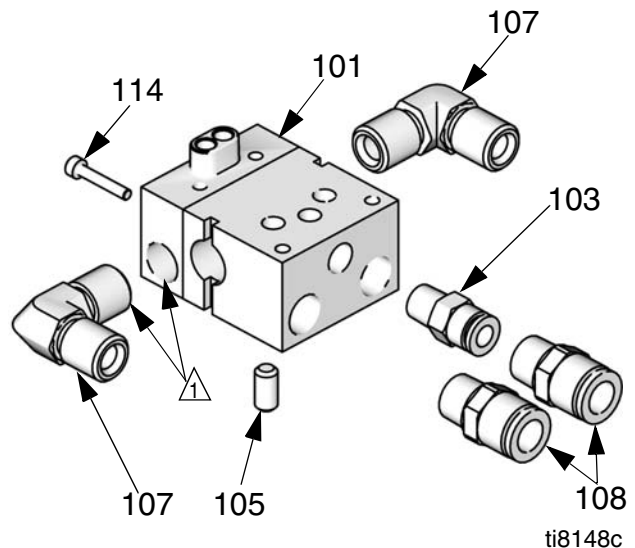

FIG. 24: Manifold with Side Fluid Ports

Part No. 288160

Rear Port Manifold, North America

Part No. 288211

Rear Port Manifold, International

Ref. No.	Part No.	Description	Qty.
101	-----	MANIFOLD, aluminum	1
103	15H521❖ 15J003◆	FITTING, fluid path 1/4 npsm #5 JIC	2
105	116475	SCREW, SHCS, M4 x 12	2
106	120353	O-RING, PTFE	2
107	15J077	O-RING, PTFE	2
110	114246	SCREW, set, hex soc	1
111	120389❖ 120537◆ 15D916◆*	FITTING, tube, air line 3/8 in. OD tube x 1/4 npt 8 mm OD tube x 1/4 npt 4 mm OD tube x 1/4 npt; shipped loose	2
112	120388❖ 120538◆	FITTING, tube, air inlet 1/4 in. OD tube x 1/8 npt(m) 6 mm OD tube x 1/8 npt(m)	1
113	103253	SCREW, set	2

* Not shown, optional size.

----- Not sold separately

❖ Part No. 288160 only.

◆ Part No. 288211 only.

① Apply sealant to threads and mating faces of manifold (101) and any fittings and/or plugs used in fluid ports.

② Torque to 8-10 in-lb (0.9–1.3 N•m).

③ Torque to 110-130 in-lb (12.3–4.7 N•m).

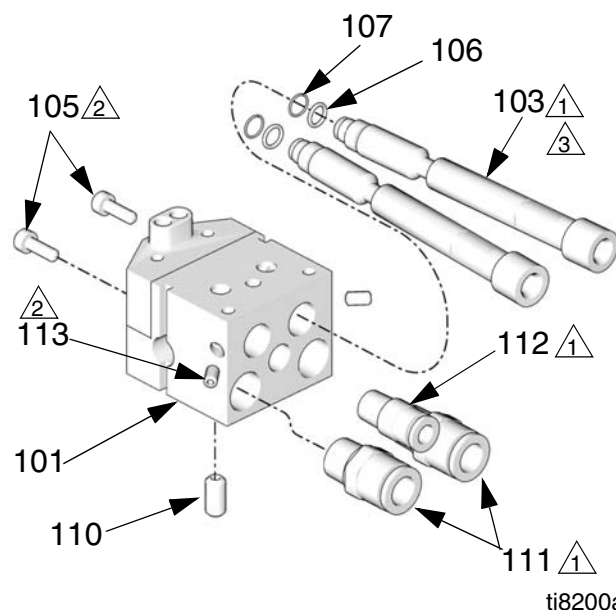

FIG. 25: Manifold with Rear Fluid Ports

Accessories

Alternate Nozzle Sizes

Gun Type	Application	Nozzle Orifice in. (mm)	Air Cap (without locating pin)	Nozzle	Needle Tip (Qty. 5)
Conventional	General Metal	0.086 (2.2)	289068	289066	289004
Conventional		0.110 (2.8)	289069	289067	289007
HVLP		0.086 (2.2)	289070	289066	289004
HVLP		0.110 (2.8)	289043	289067	289007
Compliant		0.086 (2.2)	289044	289066	289004
Compliant		0.110 (2.8)	289045	289067	289007
Conventional	Wood	0.020 (0.5)	288862	288907	289350
HVLP		0.020 (0.5)	288864	288907	289350
Compliant		0.020 (0.5)	288863	288907	289350

Stainless Steel Air Cap Kits

Gun Type	Application	Nozzle Orifice in. (mm)	Air Cap (without locating pin)	Air Cap (with Locating Pin)
Conventional	General Metal	0.020-0.055 (0.5-1.4)	24B671	24B667
Conventional		0.070 (1.8)	24B672	24B668
HVLP		0.020-0.070 (0.5-1.8)	24B669	24B665
Compliant		0.020-0.070 (0.5-1.8)	24B670	24B666

Cleaning Brush 105749

For use in cleaning gun.

Lubricant 111265

One 4 oz. (113 gram) tube sanitary (non-silicone) lubricant for fluid seals and wear areas.

Replacement Gun 24A780

Gun without needle, nozzle, and air cap.

Fluid Control Knob Repair Kit 288138

Includes spring, ball, and retaining clip.

Zero Cavity Needle Tip 24G618

1.1 mm needle tip, pack of 5.

Fluid Hose Parts Breakdown

Part No.	Description
239629	FITTING, assy, swivel
061345	TUBING, 1000 ft. (305 m) roll

Retrofit Adapter Plate 288197

The retrofit adapter plate enables the manifold to be attached to a variety of bolt patterns. See page 13 and page 42.

Gun Mounting Bracket (Cefla) Kit 24B609

Includes bracket and screw.

HVLP Pressure Verification Kit

For use in checking air cap atomizing and fan pattern air pressure at various supply air pressures. Not to be used for actual spraying.

Install the kit air cap on the gun. Turn on the air to the gun, then trigger the gun and read the air pressure on the gauge.

NOTE: To be “HVLP compliant,” the atomizing and fan pattern air pressure must not exceed 10 psi (70 kPa, 0.7 bar).

Part No.	Description
289563	HVLP General Metal
289568	HVLP High Wear 0.059 in. (1.5 mm)
289569	HVLP High Wear 0.070 in. (1.8 mm)
289566	HVLP Wood

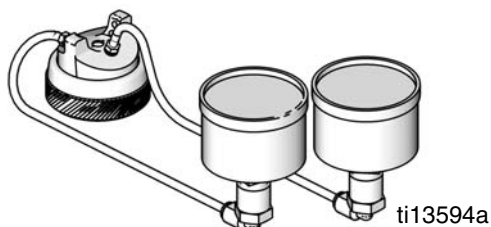

FIG. 26: HVLP Pressure Verification Kit

Inline Fluid Filter 24B707

Filter is removable without disconnecting the fluid line. Includes housing, o-ring, and 0.005 in. tip filter (equivalent to 100 mesh screen).

Spray Tip Filters

Final filter to prevent foreign particles from ruining sprayed surface smoothness.

25-Count Carton	3-Pack	Description
238562	238561	0.005 in. (equivalent to 100 mesh screen)
238564	238563	0.009 in. (equivalent to 60 mesh screen)

Tips

Part No.	Description
24E484	0.030 in. SST Needle Tips (Pack of 5)

Dimensions

Manifold Models 288217 or 288218, All Gun Models

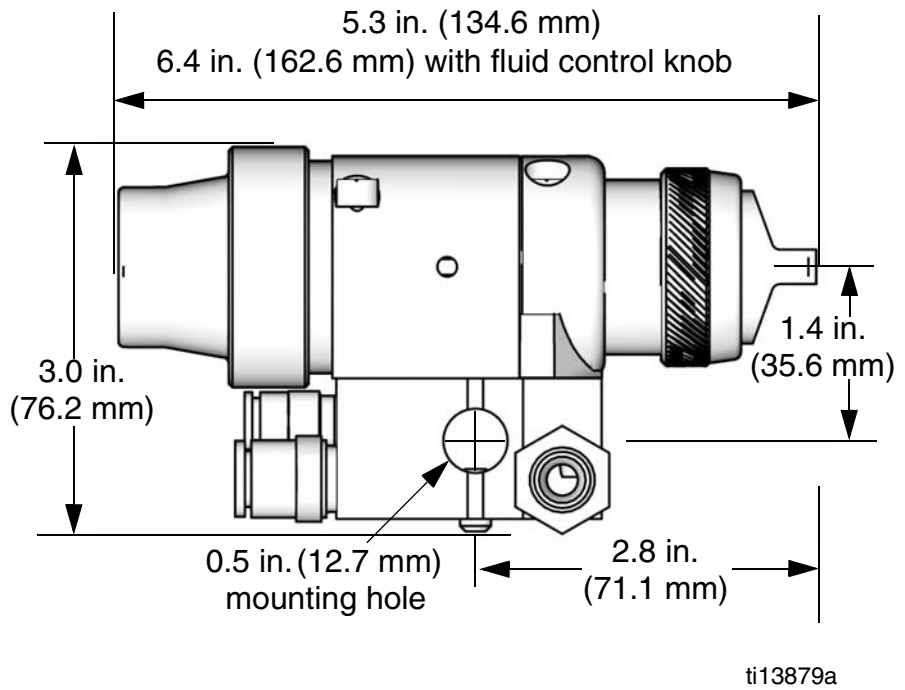
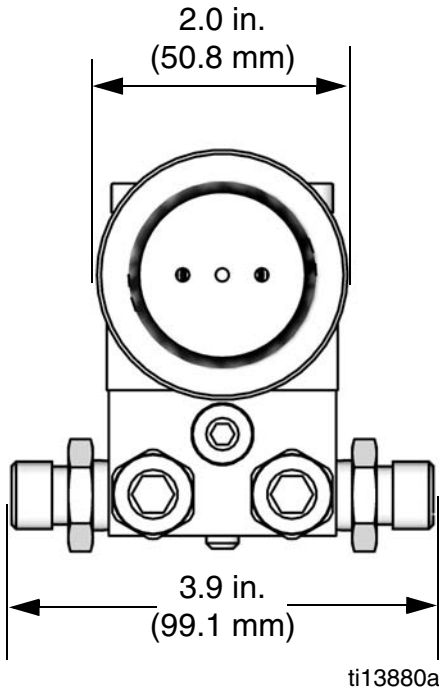

FIG. 27

Manifold Model 288221, All Gun Models

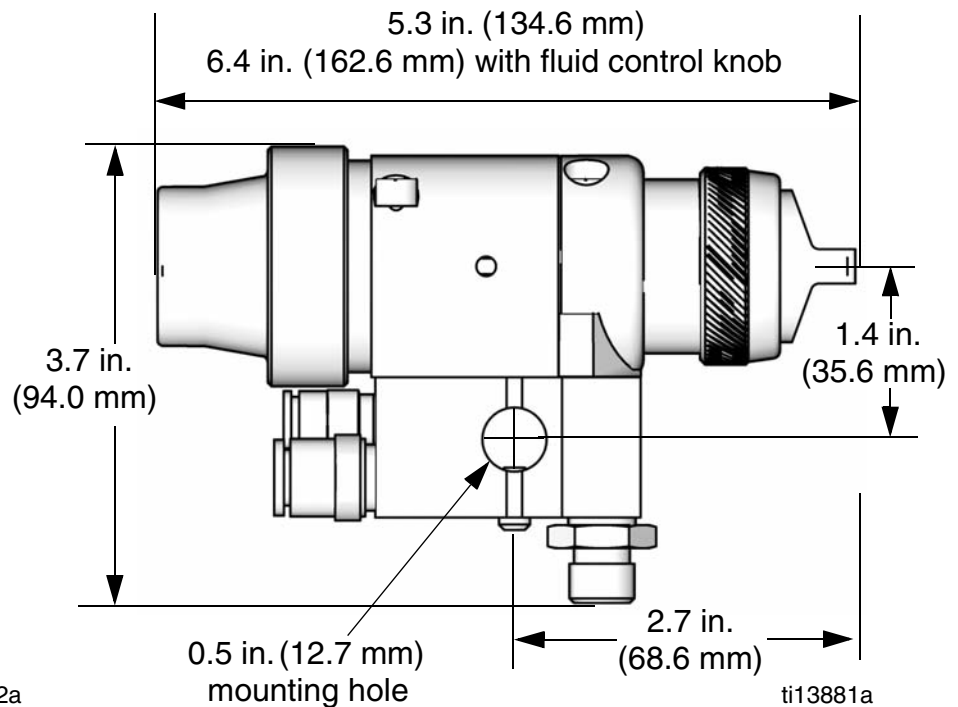
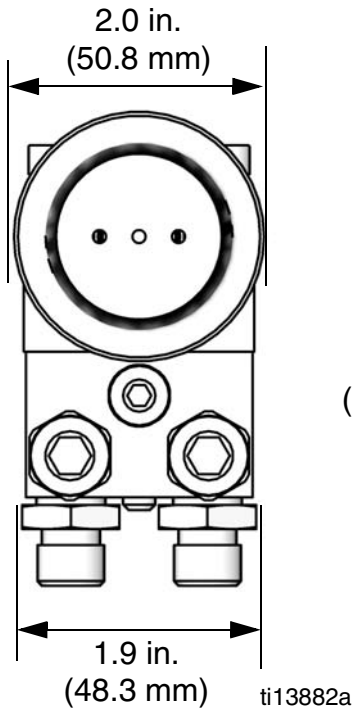

FIG. 28

Manifold Model 288223 or 24C342, All Gun Models

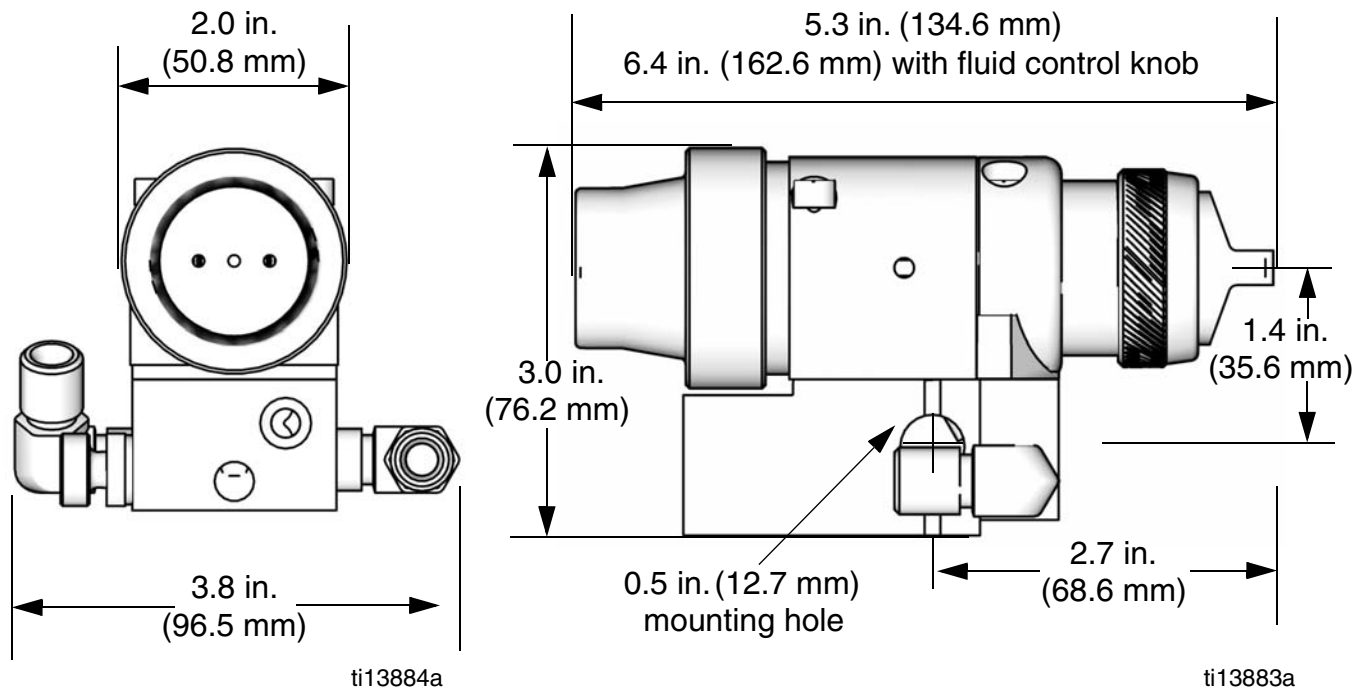

FIG. 29

Manifold Model 288160 or 288211, All Gun Models

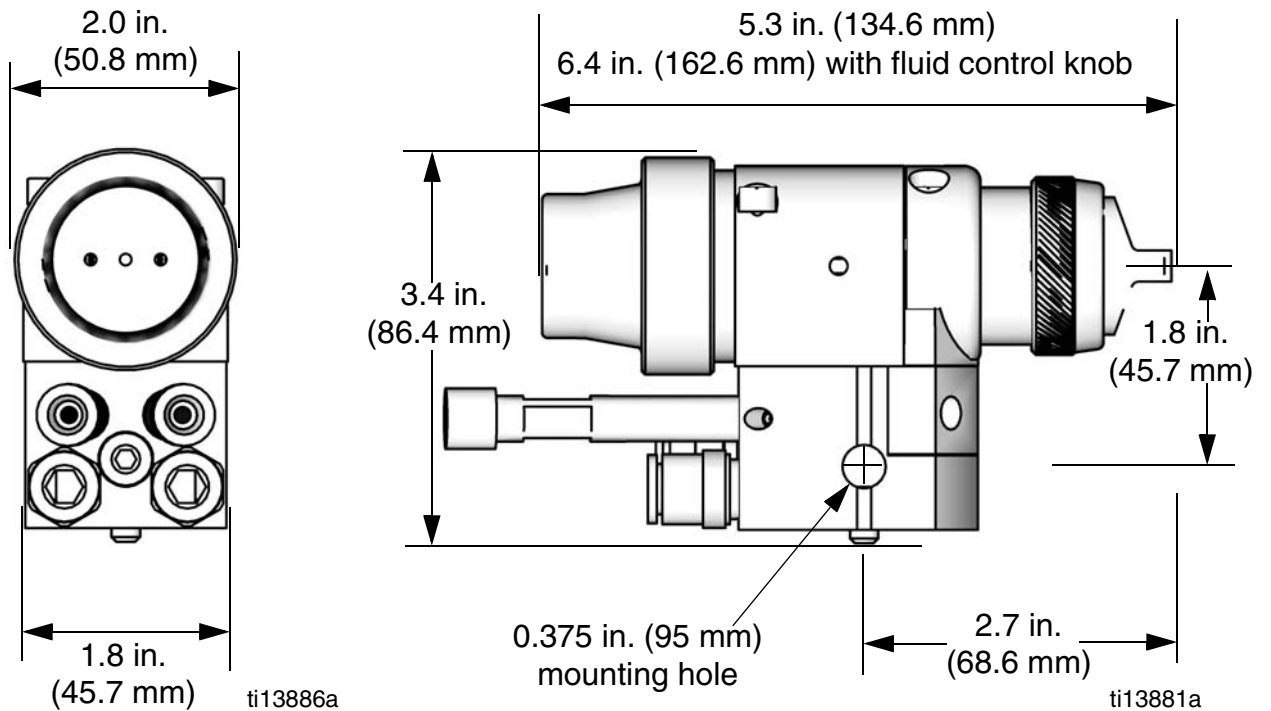
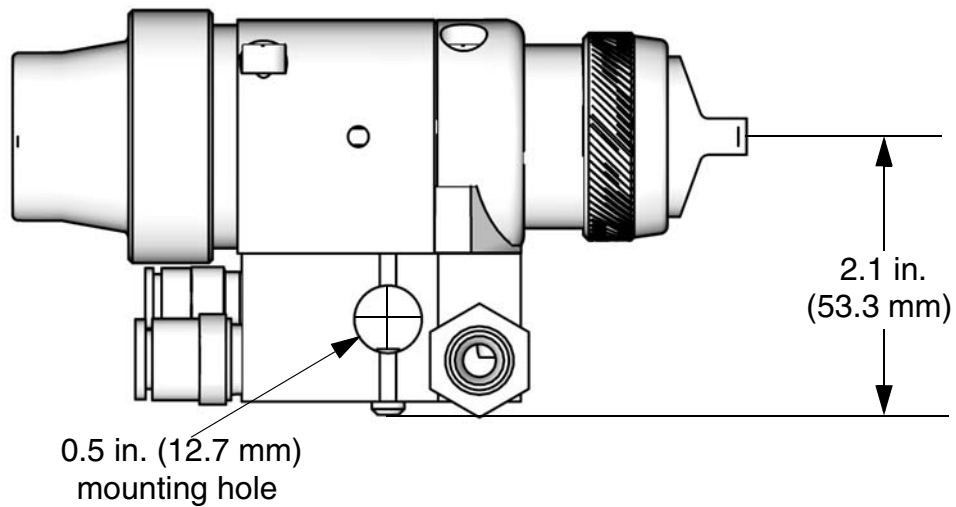
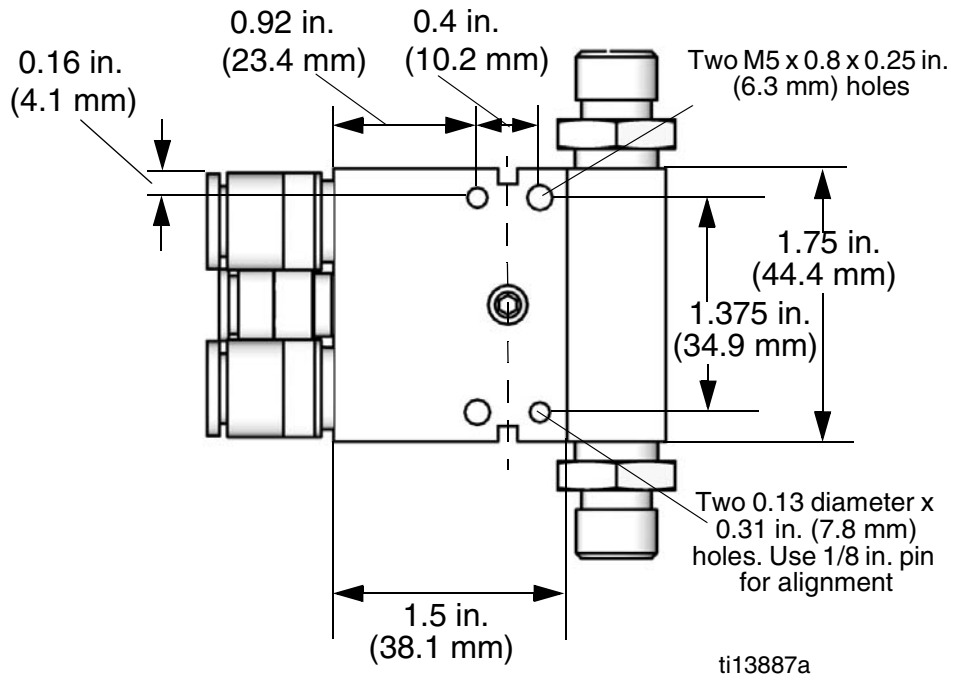

FIG. 30

Mounting Hole Layouts

Manifold Models 288217 or 288218, All Gun Models



ti13879a

FIG. 31

Manifold Model 288221, All Gun Models

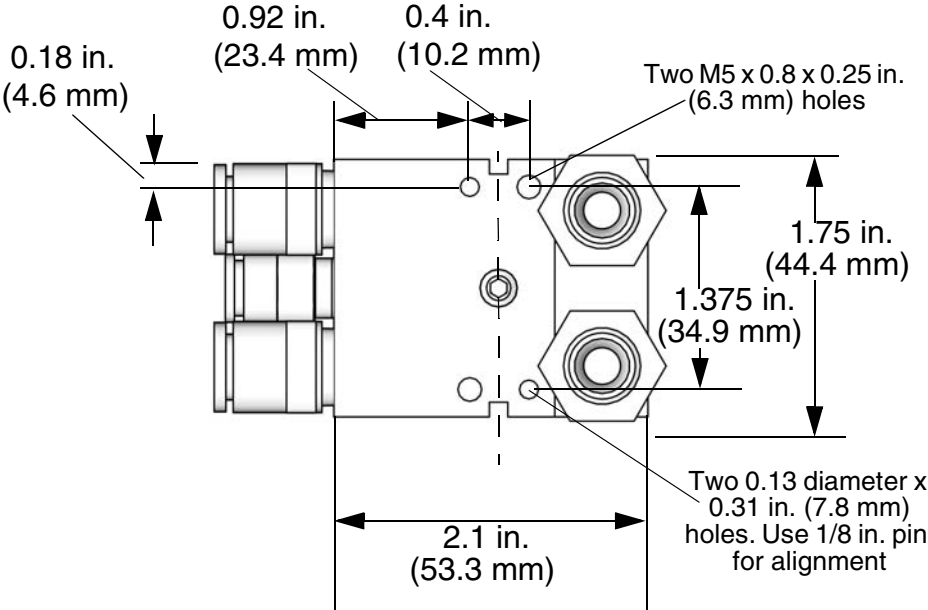

ti13888a

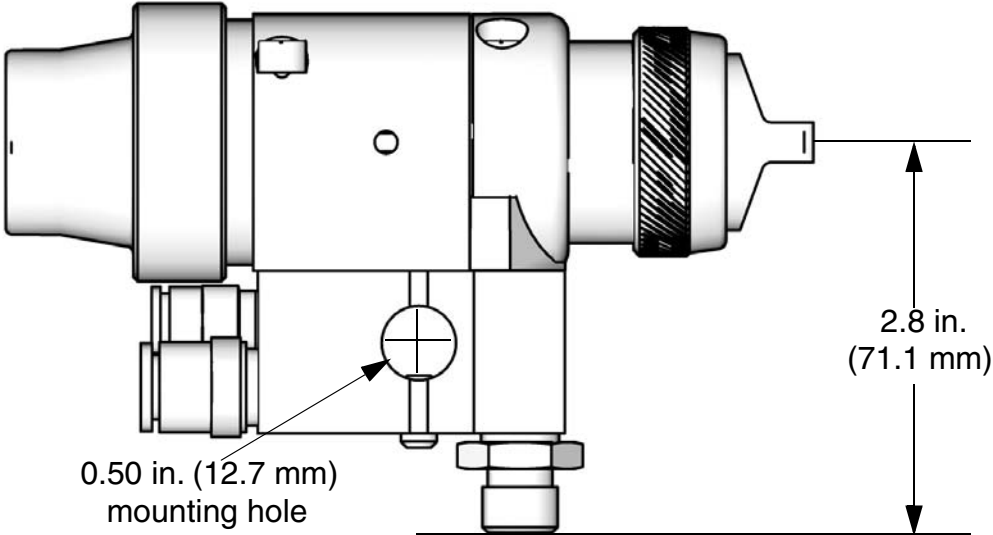

ti13881a

FIG. 32

Manifold Model 288223 or 24C342, All Gun Models

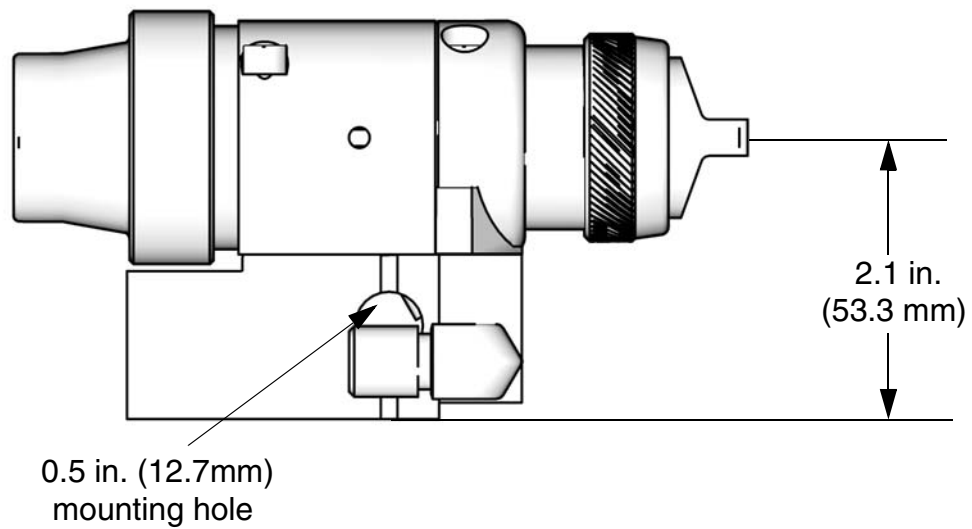
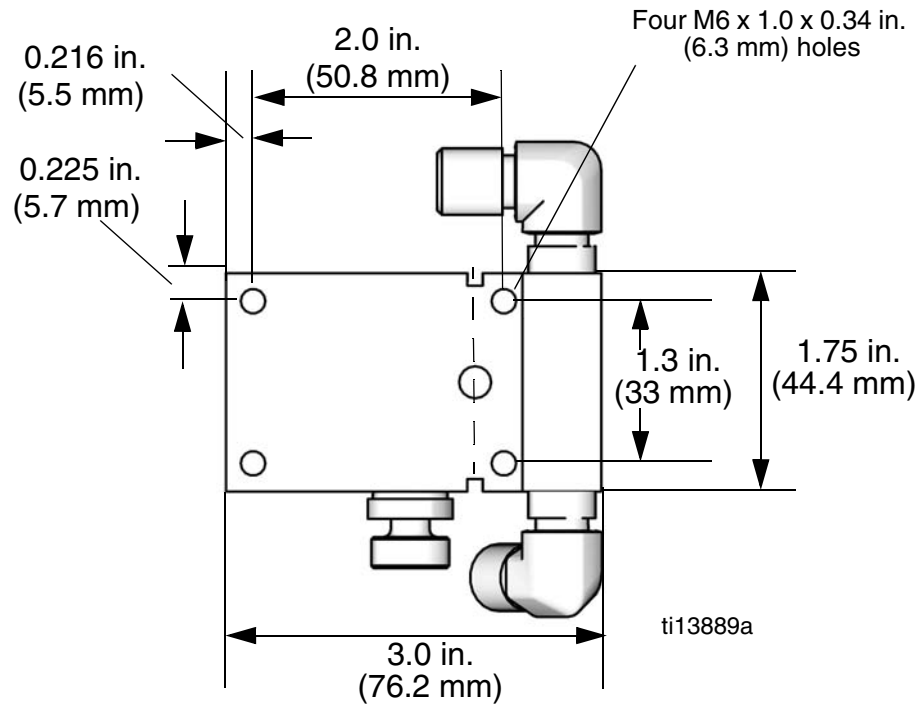
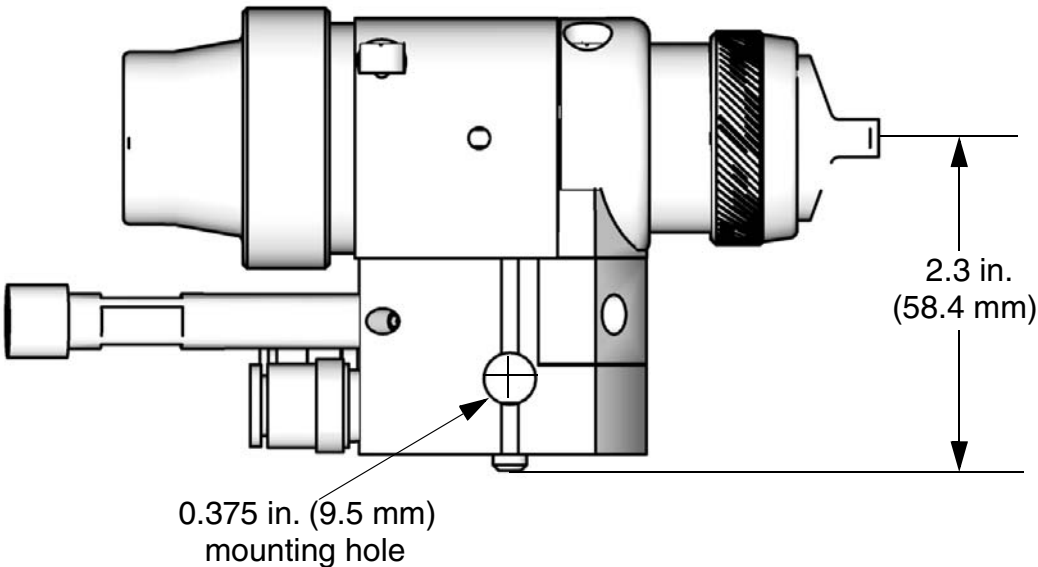
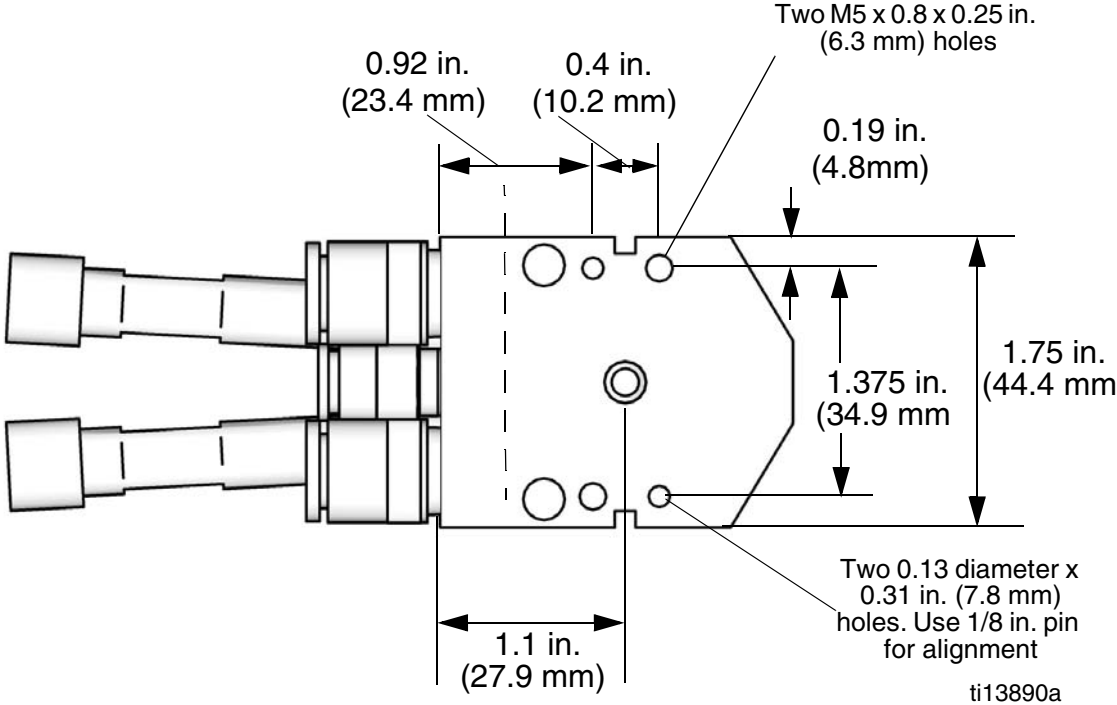

FIG. 33

Manifold Model 288160 or 288211, All Gun Models



ti13885a

FIG. 34

Retrofit Adapter Plate 288197

For use with manifold models 288217, 288218, 288221, 288216, and 288211

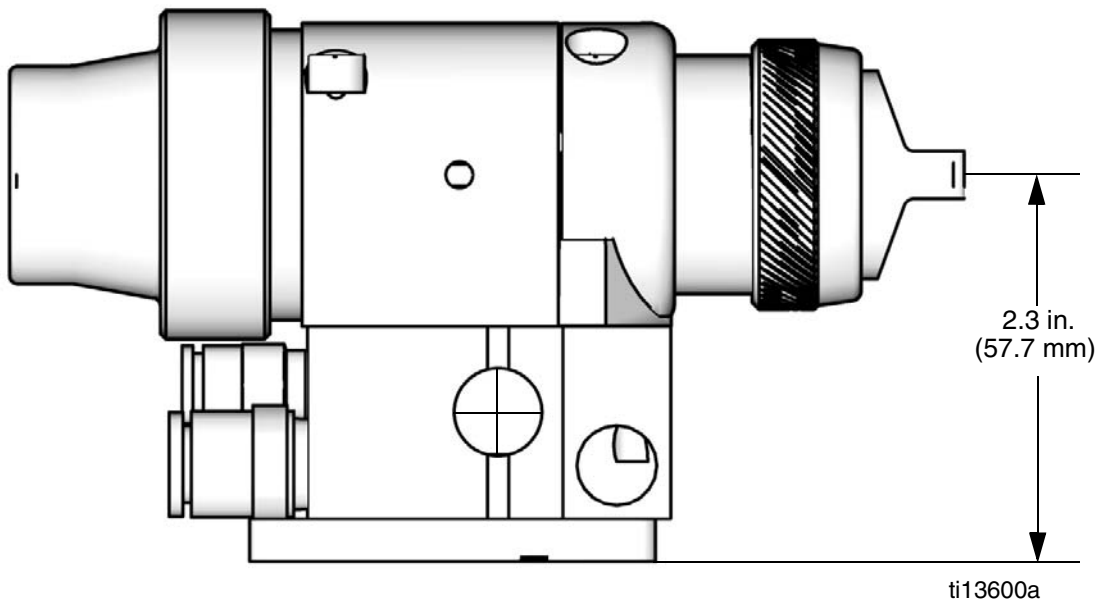
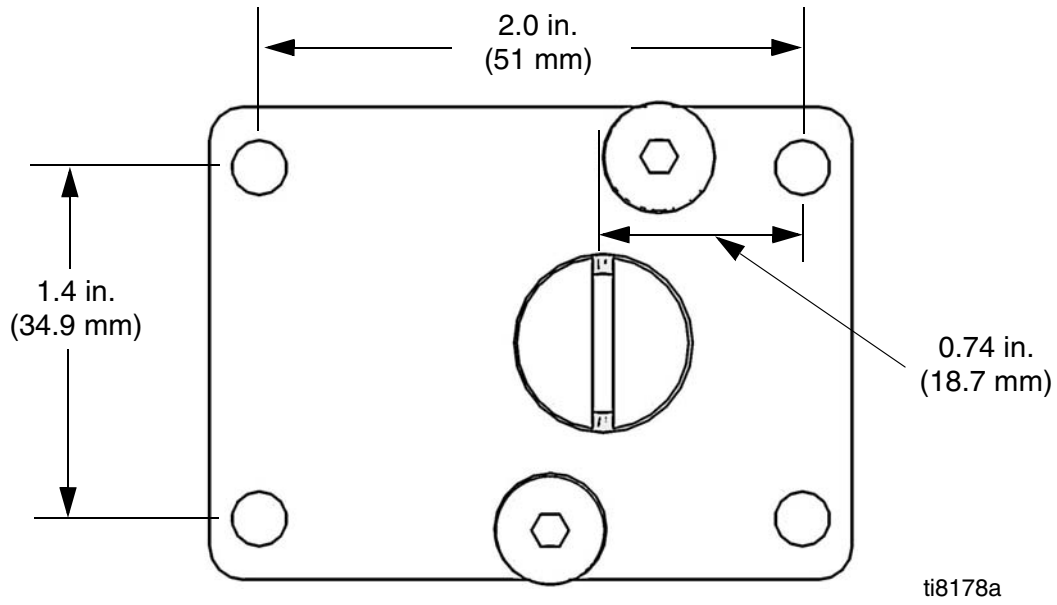

FIG. 35

Technical Data

Maximum Working Fluid Pressure	100 psi (0.7 MPa, 7 bar)
Maximum Working Air Pressure	100 psi (0.7 MPa, 7 bar)
Maximum HVLP and Compliant Gun	
Inbound Air Pressure	See chart on page 7.
Maximum Working Fluid Temperature	120° F (49° C)
Minimum Air Cylinder Actuation Pressure	50 psi (0.34 MPa, 3.4 bar)
Weight	1.5 lbs (680 g)
Wetted Parts	
Models 24B333-24B335 and 24A747-24A773	Stainless Steel, Ultra High Molecular Weight Polyethylene, Acetal, PTFE, PEEK
Models 24A774-24A779	Stainless Steel, Ultra High Molecular Weight Polyethylene, Acetal, PTFE, Tungsten Carbide

Triggering Speed

These values apply to a new gun with a 12 ft. (3.6 m), 1/4 in. (6.3 mm) OD cylinder air line and a 0.055 in. nozzle. These values will vary slightly with use and with variations in equipment.

Cylinder Air Pressure psi (kPa, bar)	Fluid Pressure psi (kPa, bar)	Air Pressure psi (kPa, bar)	msec to fully open	msec to fully close
50 (0.35, 3.5)	50 (0.35, 3.5)	100 (0.7, 7.0)	58.4	50.4

Sound Data

Conventional

Measured at 44 psi (0.30 MPa, 3.0 bar) atomizing air and 47 psi (0.32 MPa, 3.2 bar) fan air pressure

Sound Power	88.82 dBa
Sound Pressure	78.91 dBa

HVLP

Measured at 17 psi (0.12 MPa, 1.2 bar) atomizing air and 29 psi (0.20 MPa, 2.0 bar) fan air pressure

Sound Power	89.70 dBa
Sound Pressure	79.79 dBa

Compliant

Measured at 29 psi (0.20 MPa, 2.0 bar) atomizing air and 33 psi (0.23 MPa, 2.3 bar) fan air pressure

Sound Power	87.47 dBa
Sound Pressure	77.56 dBa

Sound power measured per ISO 9614-2.

Graco Standard Warranty

Graco warrants all equipment referenced in this document which is manufactured by Graco and bearing its name to be free from defects in material and workmanship on the date of sale to the original purchaser for use. With the exception of any special, extended, or limited warranty published by Graco, Graco will, for a period of twelve months from the date of sale, repair or replace any part of the equipment determined by Graco to be defective. This warranty applies only when the equipment is installed, operated and maintained in accordance with Graco's written recommendations.

This warranty does not cover, and Graco shall not be liable for general wear and tear, or any malfunction, damage or wear caused by faulty installation, misapplication, abrasion, corrosion, inadequate or improper maintenance, negligence, accident, tampering, or substitution of non-Graco component parts. Nor shall Graco be liable for malfunction, damage or wear caused by the incompatibility of Graco equipment with structures, accessories, equipment or materials not supplied by Graco, or the improper design, manufacture, installation, operation or maintenance of structures, accessories, equipment or materials not supplied by Graco.

This warranty is conditioned upon the prepaid return of the equipment claimed to be defective to an authorized Graco distributor for verification of the claimed defect. If the claimed defect is verified, Graco will repair or replace free of charge any defective parts. The equipment will be returned to the original purchaser transportation prepaid. If inspection of the equipment does not disclose any defect in material or workmanship, repairs will be made at a reasonable charge, which charges may include the costs of parts, labor, and transportation.

THIS WARRANTY IS EXCLUSIVE, AND IS IN LIEU OF ANY OTHER WARRANTIES, EXPRESS OR IMPLIED, INCLUDING BUT NOT LIMITED TO WARRANTY OF MERCHANTABILITY OR WARRANTY OF FITNESS FOR A PARTICULAR PURPOSE.

Graco's sole obligation and buyer's sole remedy for any breach of warranty shall be as set forth above. The buyer agrees that no other remedy (including, but not limited to, incidental or consequential damages for lost profits, lost sales, injury to person or property, or any other incidental or consequential loss) shall be available. Any action for breach of warranty must be brought within two (2) years of the date of sale.

GRACO MAKES NO WARRANTY, AND DISCLAIMS ALL IMPLIED WARRANTIES OF MERCHANTABILITY AND FITNESS FOR A PARTICULAR PURPOSE, IN CONNECTION WITH ACCESSORIES, EQUIPMENT, MATERIALS OR COMPONENTS SOLD BUT NOT MANUFACTURED BY GRACO. These items sold, but not manufactured by Graco (such as electric motors, switches, hose, etc.), are subject to the warranty, if any, of their manufacturer. Graco will provide purchaser with reasonable assistance in making any claim for breach of these warranties.

In no event will Graco be liable for indirect, incidental, special or consequential damages resulting from Graco supplying equipment hereunder, or the furnishing, performance, or use of any products or other goods sold hereto, whether due to a breach of contract, breach of warranty, the negligence of Graco, or otherwise.

FOR GRACO CANADA CUSTOMERS

The Parties acknowledge that they have required that the present document, as well as all documents, notices and legal proceedings entered into, given or instituted pursuant hereto or relating directly or indirectly hereto, be drawn up in English. Les parties reconnaissent avoir convenu que la rédaction du présente document sera en Anglais, ainsi que tous documents, avis et procédures judiciaires exécutés, donnés ou intentés, à la suite de ou en rapport, directement ou indirectement, avec les procédures concernées.

Graco Information

For the latest information about Graco products, visit www.graco.com.

TO PLACE AN ORDER, contact your Graco distributor or call to identify the nearest distributor.
Phone: 612-623-6921 **or Toll Free:** 1-800-328-0211 **Fax:** 612-378-3505

*All written and visual data contained in this document reflects the latest product information available at the time of publication.
Graco reserves the right to make changes at any time without notice.*

Original instructions. This manual contains English. MM 313516

Graco Headquarters: Minneapolis
International Offices: Belgium, China, Japan, Korea

GRACO INC. AND SUBSIDIARIES • P.O. BOX 1441 • MINNEAPOLIS MN 55440-1441 • USA

Copyright 2009, Graco Inc. All Graco manufacturing locations are registered to ISO 9001.

www.graco.com
Revised 01/2012